



Equipped with AEM® Dryflow™ Filter
No Oil Required!

INSTALLATION INSTRUCTIONS

PART NUMBER:

- | | |
|----------------|--------------------------------------|
| 21-413B | (Blue Finish) |
| 21-413C | (Gun Metal Grey Finish) |
| 21-413P | (Vacuum Metalized Chrome-VMC) |
| 21-413R | (Red Finish) |

1996-2000 HONDA Civic CX/DX/LX L4-1.6L C.A.R.B. E.O. # D-670-15

**Intake systems for vehicles listed are 50
state legal. See AEMIntakes.com for CARB
status on each part for a specific vehicle.**

PARTS LIST

Part Number	Qty.	Part Number
Element Parts Kit 2.50 X 5" Dry Ele.	1	21-201DK
Upper Pipe	1	2-425
Lower Pipe	1	2-426
Hose; 5/16ID X 16"L	1	5-2016
Hose, Silicone 2.50x3" Blk.	2	5-250
Mount, Rubber 1" X 6mm	1	1228599
Grommet, 3/8"	1	784633
Hose; 1/2"ID X 7"L	1	5-5007
Washer, 6mm Soft Mount	1	08160
Nut, M6 Hex Serrated	1	444.460.04
Hose Clamp, 3/4"	2	4093-5
1/2' Bnd. Hose Clamp, 2.15-3.00"	4	9440
1/2" Bnd. Hose Clamp, 2.31-3.25"	1	9444
Hose Clamp, 1"	2	08407

Read and understand these instructions BEFORE attempting to install this product. Failure to follow installation instructions and not using the provided hardware may damage the intake tube, throttle body and engine.

The AEM[®] intake system is a performance product that can be used safely during mild weather conditions. During harsh and inclement weather conditions, you must return your vehicle to stock OEM air box and intake tract configuration. Failure to follow these instructions will void your warranty.

1. Preparing Vehicle

- a. Make sure vehicle is parked on level surface.
- b. Set parking brake.
- c. If engine has run in the past two hours, let it cool down.
- d. Disconnect negative battery terminal.
- e. Do not discard stock components after removal of the factory system.

2. Removal of stock system

- a. Raise the front of the vehicle with a jack. Refer to your owner's manual for proper jack and jack stand placement to properly support vehicle. Support your vehicle using properly rated jack stands before wheel removal or while working under the vehicle.
NEVER WORK UNDER A VEHICLE WITHOUT USING JACK STANDS.
 - i. Remove the front lower splash shield. (Fig 1)
 - ii. Remove the passenger side wheel. Loosen the passenger-side fender well liner and remove to gain access to the area immediately behind the front bumper. (Fig 2)
- b. Loosen and remove the resonator hold down bolts. (Fig 4)
- c. After removing the bolts, remove the air inlet duct from the air filter case on the throttle body.
- d. Remove the breather hose from the base of the filter case and from the cam cover (Fig. 5).
- e. **NOTE: The engine should be cool before performing this step so that HOT coolant is not released out of the engine. Be sure to capture any lost coolant in a clean container.**
Disconnect the water bypass hose from throttle body or the fast idle thermo valve, where equipped, located at the lower portion of the throttle body. Disconnect the opposite side of the water bypass hose, which runs to either the intake manifold or the water outlet neck. Remove the entire water bypass hose and breather hose assembly from the vehicle.
- f. Loosen and remove the bottom bolt that holds the filter case to the throttle body (Fig 6).
- g. Remove the inlet air temperature sensor from the filter case and set aside for re-installation later (Fig 6).
- h. Loosen the clamp at the base of the filter case and lift the filter case out of the engine bay.
NOTE: The harness for the air temp sensor is attached to the base of the filter case. Remove the harness from the support before you pull the filter case away.

3. Installation of AEM[®] intake system.

- a. When installing the intake system, do not completely tighten the hose clamps or mounting hardware until instructed to do so.
- b. The primary intake pipe has a breather tube and a hole for the IAT sensor, this end of the intake pipe will attach to the throttle body.
- c. The bracket at the inlet end of the primary intake pipe will line up close to a bolt that secures a wire loom bracket to the shock tower. Remove the bolt and install the rubber isolator mount supplied with the kit into this threaded hole.
- d. Install the supplied rubber grommet into the hole in the intake pipe. Then carefully insert the IAT sensor into the grommet installed in the primary intake pipe.

- e. Install one of the black connector hoses onto the end of the intake pipe that attaches to the throttle body. Also install two hose clamps onto the connector hose. Install the intake pipe.
- i. The support tab on the inlet pipe will line up with the rubber isolator mount. Attach the air inlet tube onto the rubber mount. Install the large fender washer and the lock nut onto the isolator mount stud and snug it down.

NOTE: Failure to install the rubber mount will void all warranties of the intake system. Below is a diagram of how the rubber mount should be installed.

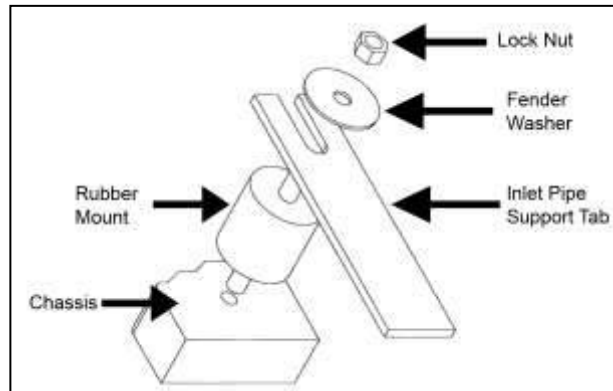

- f. Reattach the wire harness for the inlet air temperature sensor.
- g. Install the secondary intake pipe.
 - i. Install another black connector and hose clamps onto the end of the primary pipe.
 - ii. The secondary intake pipe is installed with the 90 degree bend on the bottom and towards the right side of the vehicle. The air filter end of the intake pipe will reside in the area exposed by removal of the inner fender liner.
- h. Install the AEM[®] air filter onto the end of the intake pipe. Push the air filter on around 2 inches over the intake pipe and install one hose clamp to secure the air filter onto the intake pipe. Once fitment is checked, you can either push the air filter onto the inlet pipe more or less depending on clearances. Tighten the hose clamp after this is done.
- i. Using the enclosed 1/2" ID hose, connect the breather port on the cam cover to the port on the inlet pipe. Use the two 3/4" hose clamps supplied.
- j. Connect the new supplied water bypass hose and clamps to the throttle body or the fast idle thermo valve, where equipped, and either the intake manifold or the water outlet neck disconnected earlier.

NOTE: Replace any coolant recovered during the hose removal by replenishing the recovery tank.

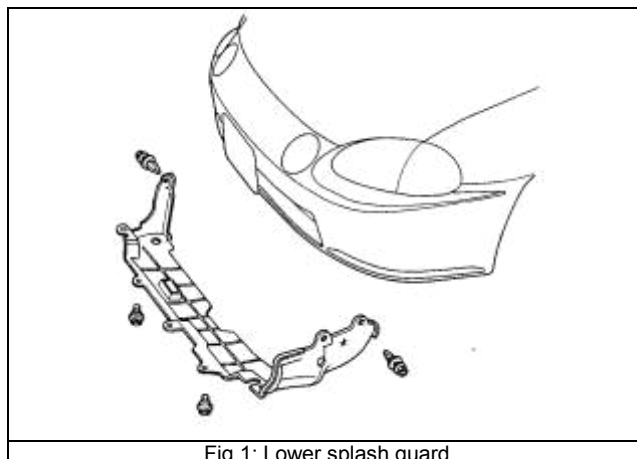

Fig.1: Lower splash guard

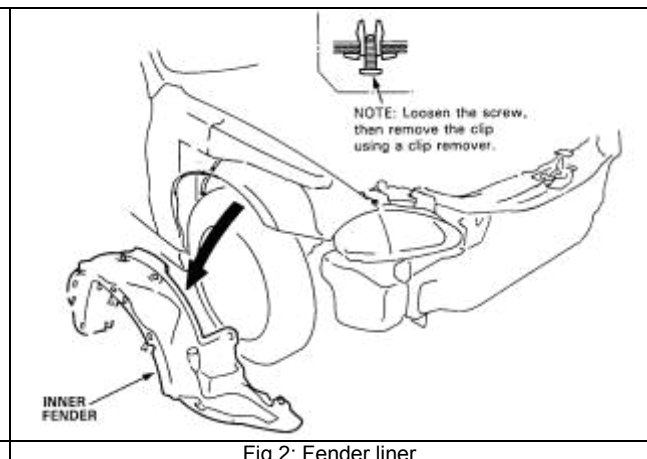

Fig.2: Fender liner

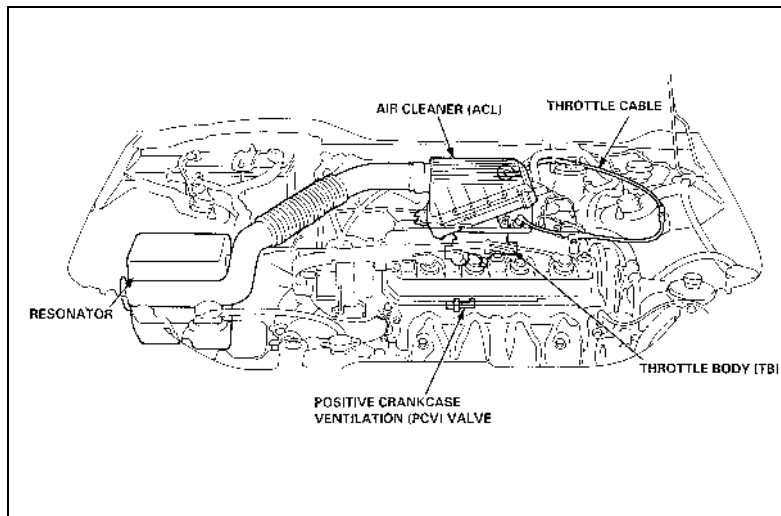

Fig.3: Air inlet layout

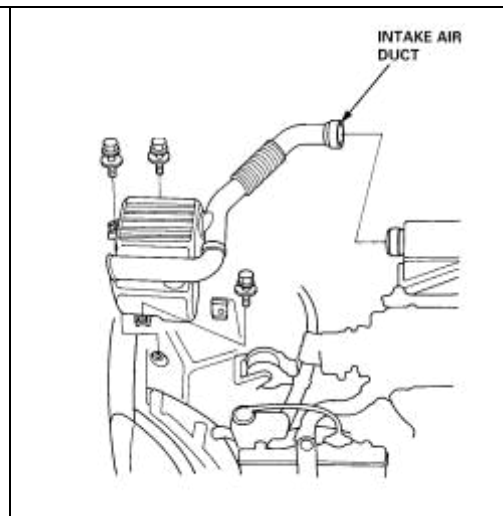

Fig.4: Removing air inlet resonator

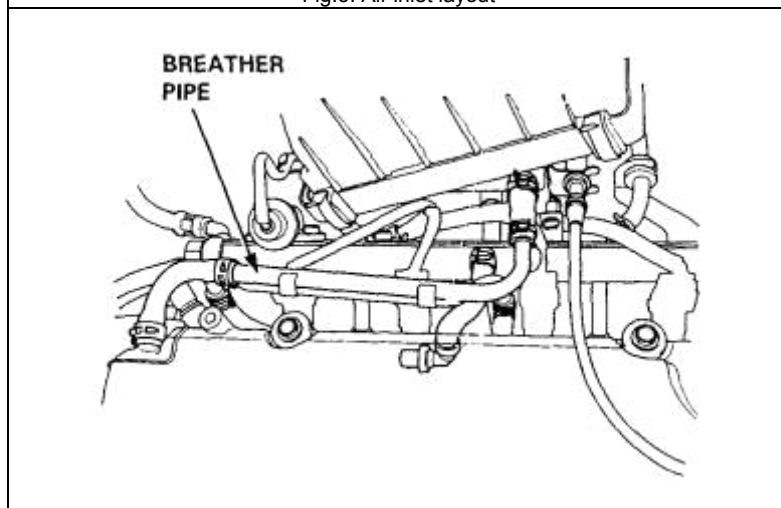

Fig.5: Breather pipe connections

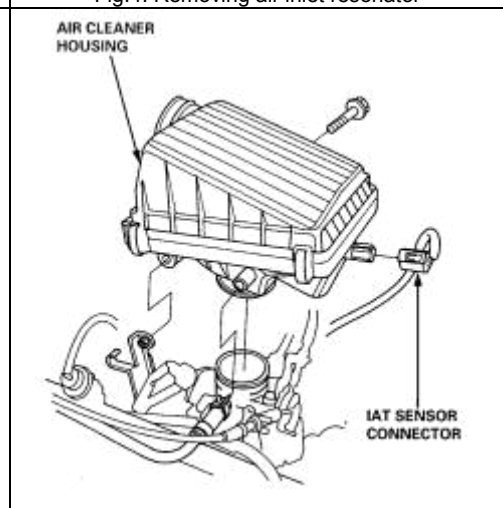

Fig.6: Removing air filter case

4. Reassemble Vehicle

- a. **Fender liner and Lower Front Splashguard:** Install the fender liner, lower splashguard and any hardware that was removed in steps 2a i. and 2a ii.
NOTE: Failure to install the fender liner and splash guard will result in diminished performance and increase the potential for engine damage due to water ingestion in rainy conditions.
- b. **Wheel:** Install the passenger side wheel using the factory torque specification (see owner's manual).
- c. Position the inlet pipes for the best fitment. Be sure that the pipes or any other components do not contact any part of the vehicle. Tighten the rubber mount, all bolts, and hose clamps.
- d. Check for proper hood clearance. Re-adjust pipes if necessary and re-tighten them.
- e. Inspect the engine bay for any loose tools and check that all fasteners that were moved or removed are properly tightened.
- f. Reconnect negative battery terminals and start engine. Let the vehicle idle for 3 minutes. Perform a final inspection before driving the vehicle.

5. CARB Sticker Placement

- a. The C.A.R.B. exemption sticker, (attached), must be visible under the hood so that an emissions inspector can see it when the vehicle is required to be tested for emissions. California requires testing every two years, other states may vary.

6. Service and Maintenance

- a. It is recommended that you service your AEM® Dryflow™ filter every 20,000 miles for optimum performance. Use AEM Dryflow cleaning kit part # 21-110.
- b. Use aluminum polish to clean your polished AEM® intake tube.
- c. Use window cleaner to clean your powder coated AEM® intake tube. **(NOTE: DO NOT USE aluminum polish on powder coated AEM intake tubes).**

For technical inquiries
e-mail us at
sales@aemintakes.com
or
call us at
800.992.3000

AEM Air Intake System Warranty Policy

AEM® warrants that its intake systems will last for the life of your vehicle. AEM will not honor this warranty due to mechanical damage (i.e. improper installation or fitment), damage from misuse, accidents or flying debris. AEM will not warrant its powder coating if the finish has been cleaned with a hydrocarbon-based solvent. The powder coating should only be cleaned with a mild soap and water solution. Proof of purchase of both the vehicle and AEM intake system is required for redemption of a warranty claim.

This warranty is limited to the repair or replacement of the AEM part. In no event shall this warranty exceed the original purchase price of the AEM part nor shall AEM be responsible for special, incidental or consequential damages or cost incurred due to the failure of this product. Warranty claims to AEM must be transportation prepaid and accompanied with dated proof of purchase. This warranty applies only to the original purchaser of product and is nontransferable. Improper use or installation, use for racing, accident, abuse, unauthorized repairs or alterations voids this warranty. AEM disclaims any liability for consequential damages due to breach of any written or implied warranty on all products manufactured by AEM. Warranty returns will only be accepted by AEM when accompanied by a valid Return Merchandise Authorization (RMA) number. Credit for defective products will be issued pending inspection. Product must be received by AEM within 30 days of the date RMA is issued.

If you have a warranty issue, please call (800) 992-3000 and our customer service department will assist you. A proof of purchase is required for all AEM warranty claims.

**Intake systems for vehicles listed are 50
state legal. See AEMIntakes.com for CARB
status on each part for a specific vehicle.**