



Equipped with AEM® Dryflow™ Filter
No Oil Required!

INSTALLATION INSTRUCTIONS

PART NUMBER:

21-425B (Blue Finish)

21-425P (Vacuum Metalized Chrome-VMC)

21-425R (Red Finish)

2003-2005 DODGE Neon SRT-4 L4 2.4L Turbo C.A.R.B. E.O. # D-670-15

Intake systems for vehicles listed are 50 state legal. See AEMIntakes.com for CARB status on each part for a specific vehicle.

PARTS LIST

	Description	Qty.	Part Number
A	Element Parts Kit 3.00 X 5" Dry Ele.	1	21-203DK
B	1/2" Bnd. Hose Clamp, 2.90"-3.75"	1	9452
C	Lower Pipe	1	9-568
D	Bolt, Hex/Flange M6-1 X 20	6	1-2038
E	Washer, M6 Split Lock Zinc	2	1-3025
F	Nut, M6 Hex Serrated	7	444.460.04
G	Washer, 6mm Soft Mount	5	08160
H	Bracket	1	7-7779
I	Mount, Rubber 1" X 6mm	1	1228599
J	Grommet	1	08064
K	1/2" Bnd. Hose Clamp, 2.56"-3.50"	3	9448
L	Hose, Silicone 3.00x2" Black	1	5-302
M	Upper Pipe	1	2-567
N	Hose Clamp, 1"	2	08407
O	Hose; 1/2"ID X 2"L	1	5-5002
P	Elbow, 3.00/2.362 90 Deg.	1	5-303
Q	1/2' Bnd. Hose Clamp, 2.15-3.00"	1	9440
R	Connector, Plastic 3/8" Straight	1	8-125
S	Hose Clamp, 3/4"	1	4093-5
T	Hose; 3/8"ID X 8"L	1	5-1008
U	Bracket	1	7-7246
V	Mount, Rubber 5/8" X 6mm	1	1228598
W	Splash Shield	1	20-425
X	Washer, M6 X 12mm OD SS	2	1-3016
Y	Rubber Edge Trim 15"	1	8-3015
Z	Neoprene, 1/16" X 4" X 3" Adhes.	1	8-126-3

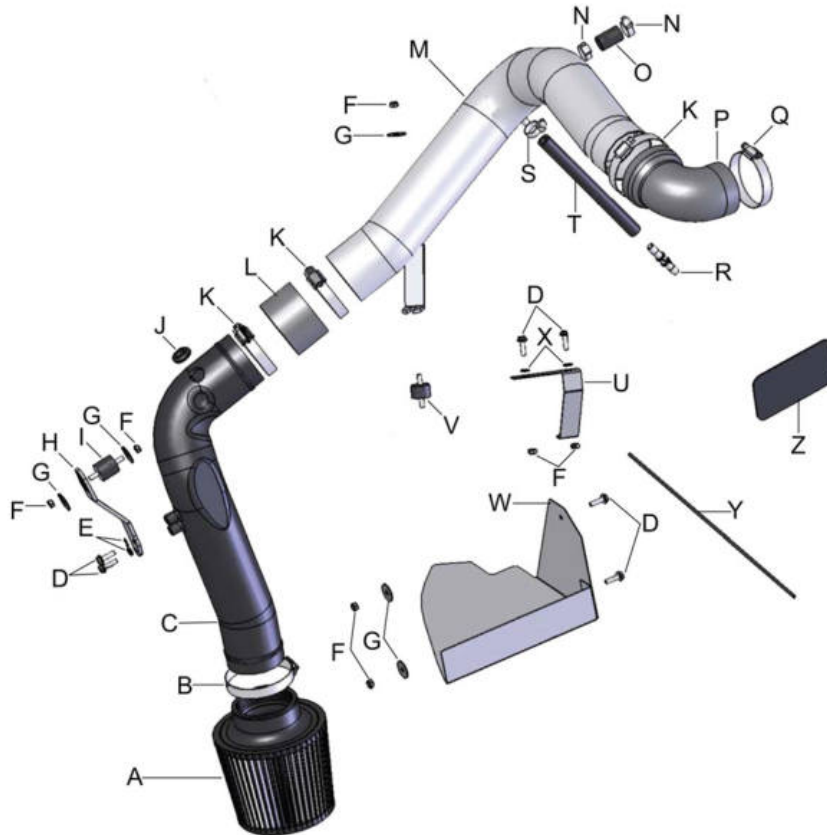

Read and understand these instructions **BEFORE** attempting to install this product. Failure to follow installation instructions and not using the provided hardware may damage the intake tube, throttle body and engine.

1. Preparing Vehicle

- a. Make sure vehicle is parked on level surface.
- b. Set parking brake.
- c. If engine has run in the past two hours, let it cool down.
- d. Disconnect negative battery terminal.
- e. Raise the front of the vehicle with a jack. Refer to your owner's manual for proper jack and jack stand placement to properly support vehicle. Support your vehicle using properly rated jack stands before wheel removal or while working under the vehicle.

NEVER WORK UNDER A VEHICLE WITHOUT USING JACK STANDS.

- f. Do not discard stock components after removal of the factory system.

2. Removal of stock system

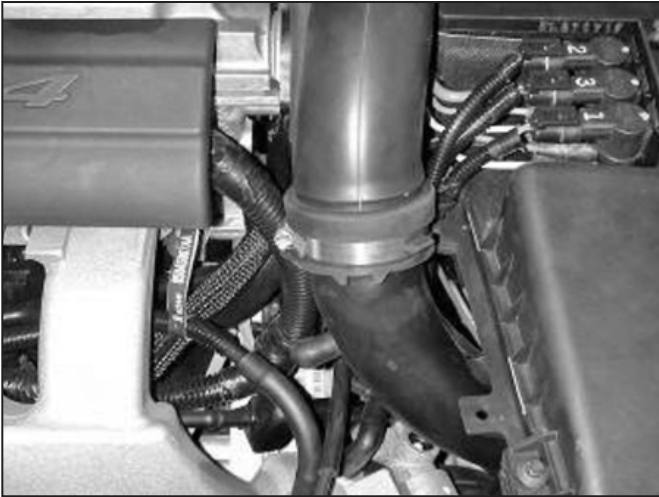

a. Loosen the hose clamp near the air box.

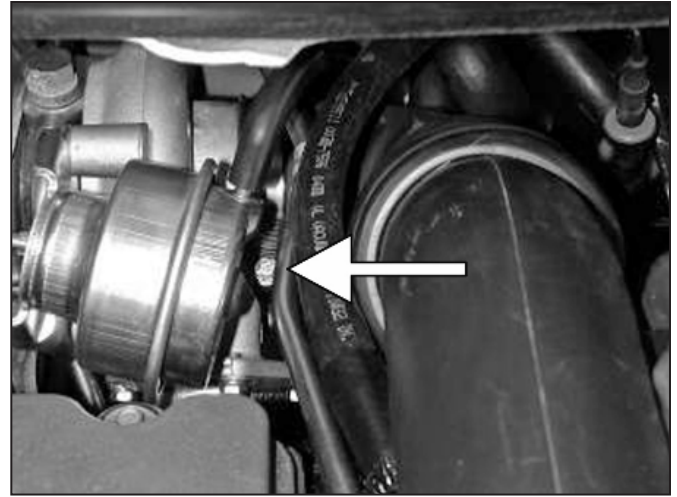

b. Loosen the hose clamp at the turbo inlet.



c. Remove the inlet air tube to the turbo.

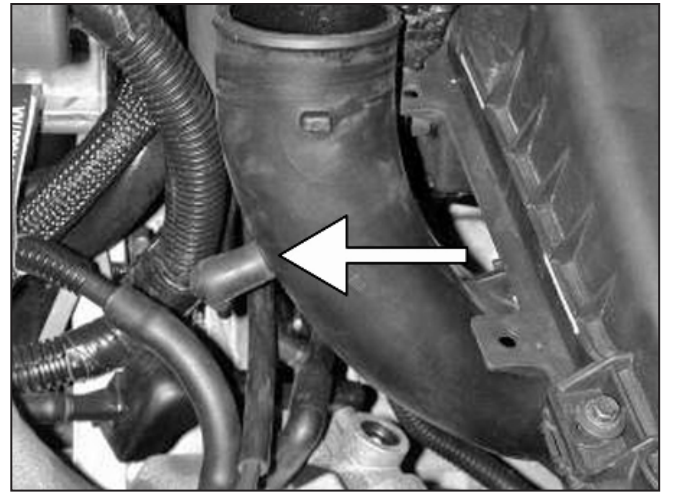

d. Unplug the vacuum cap at the base of the air box.

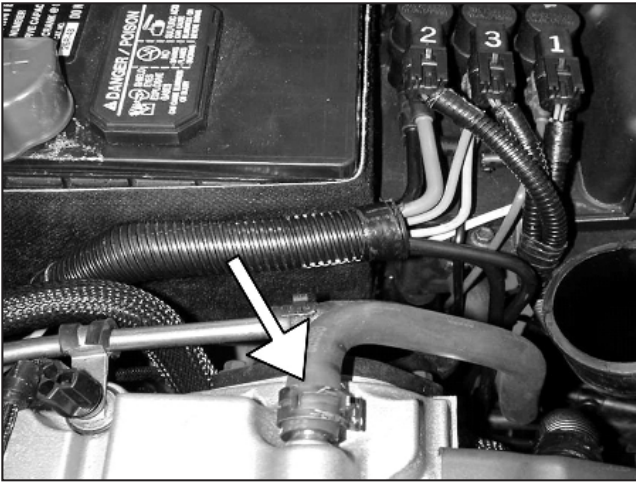

e. Remove the breather hose from the nipple on the valve cover. Check for oil, if present clean as necessary.

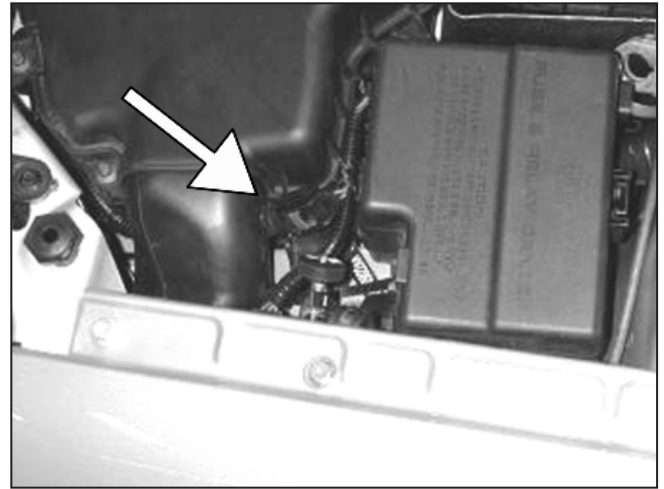

f. Remove the IAT sensor from the air box.

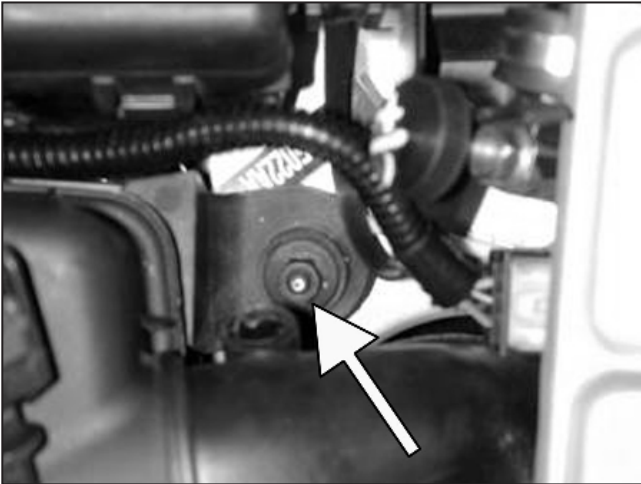

g. Loosen and remove nut holding down the air box. This nut is located by the vacant hole left by the IAT sensor.

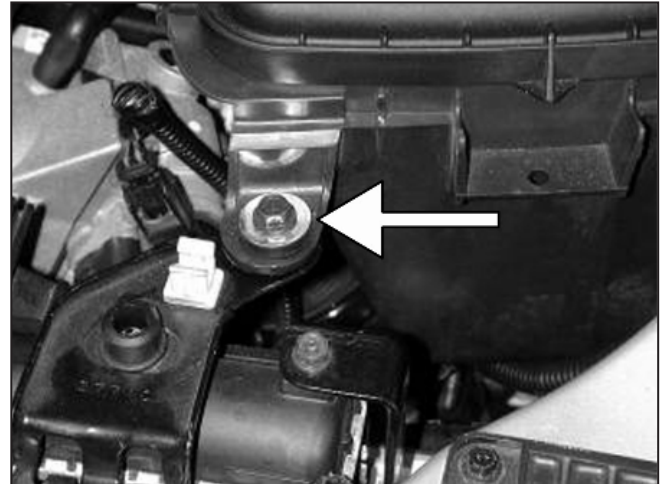

h. Remove the bolt holding down the air box to the radiator support.



i. Remove the 2 screws holding down the vacuum assembly to the air box.

3. Installation of AEM® intake system.

a. When installing the intake system, do not completely tighten the hose clamps or mounting hardware until instructed to do so.

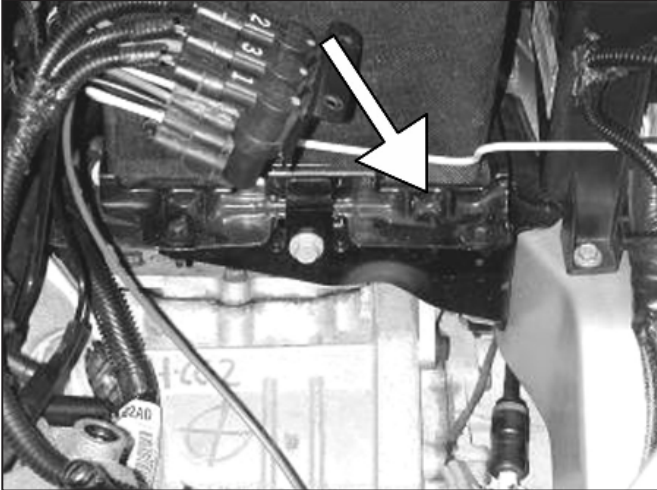

b. Loosen and remove the bolt on the right side of the battery bracket.

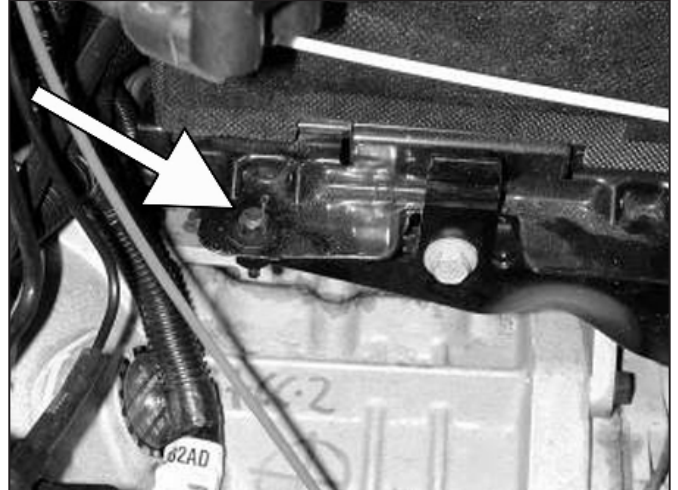

c. Loosen the bolt on the left side of the battery bracket.

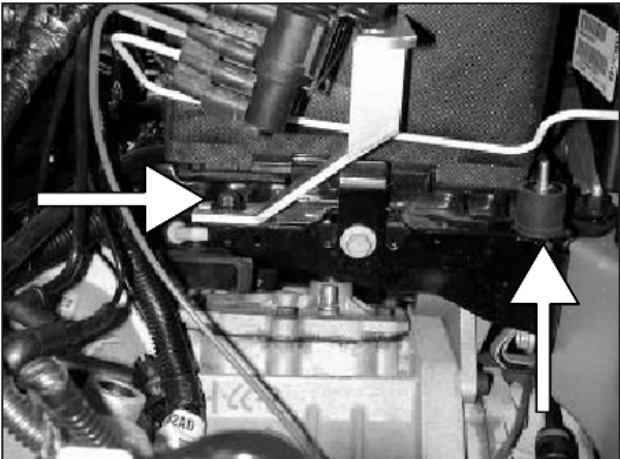

d. Insert rubber mount on the right side of the battery bracket. Attach the vacuum assembly bracket to the left side as shown. Secure the vacuum assembly bracket to the battery bracket.

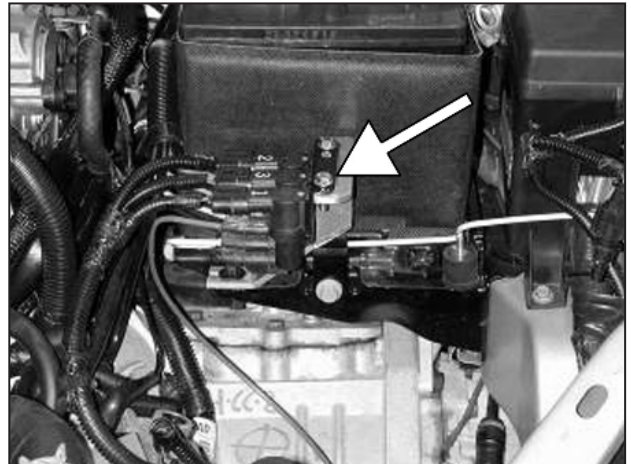

e. Secure the vacuum assembly to the vacuum assembly bracket. Make sure all the hard vacuum lines are clear of any obstruction.



f. Attach the 3" side of the silicon elbow to the inlet pipe. Secure the elbow to the inlet pipe with the included hose clamp. The open end connects to the turbo inlet which sits horizontal. This opening is furthest away from the bracket.

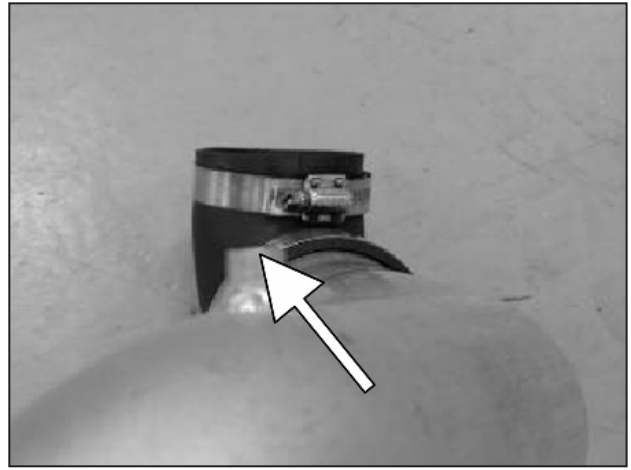

g. The opening of the coupler should be facing the same direction as the short nipple for proper alignment.

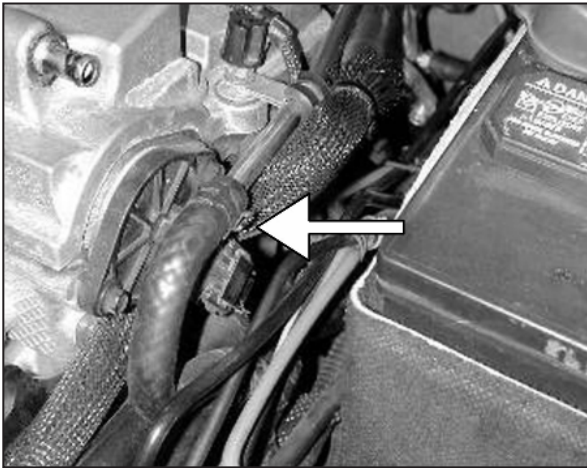

h. For more clearance, rotate the clip located near the crankcase vent so the tabs are directed towards the bottom of the car.



i. Insert the inlet pipe. Attach the coupler to the turbo and line up the bracket to the rubber mount.



j. Check for clearance around the battery, all breather hoses and hard lines. You should have at least 1" of clearance from the inlet pipe and the positive battery terminal. If not you will need to readjust the battery to the further most right position on the battery tray. **If the terminal cover is damaged, cracked or melted you will need to replace immediately before installation. Failure to abide by Step 3j will void all warranty.**

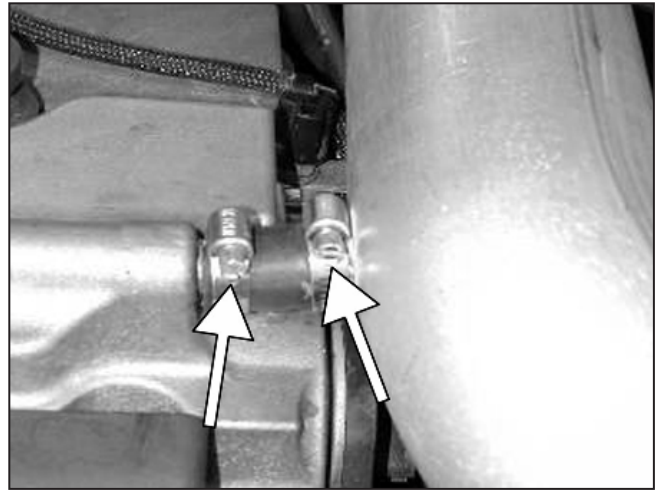

k. Attach the 1/2" diameter breather hose to the crankcase and inlet pipe. Make sure the nipples are inserted completely in the hose. Secure with provided hose clamps.



l. Insert the straight barded fitting into the vacuum cap from step 2d. Attach the 3/8" diameter breather hose to the other end of the barbed fitting.



m. Secure the other end of the breather hose to the upper inlet pipe with the provided hose clamp.

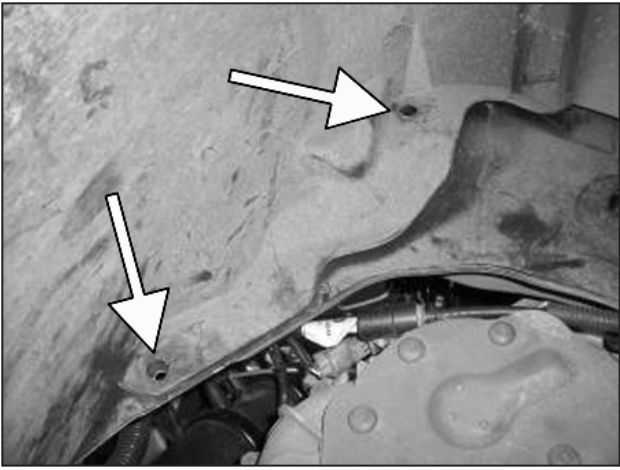

n. Remove the driver's side front wheel. Remove push in tabs from the fender liner. Do not throw away the fender liner hardware. They will be reused.

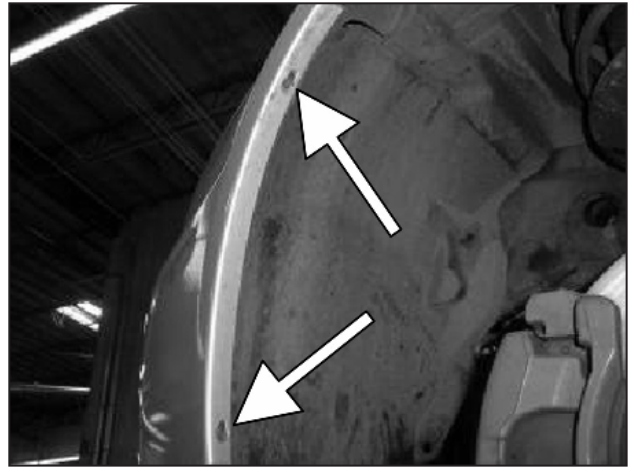

o. Remove the two TORX screws (T20) from the fender liner.

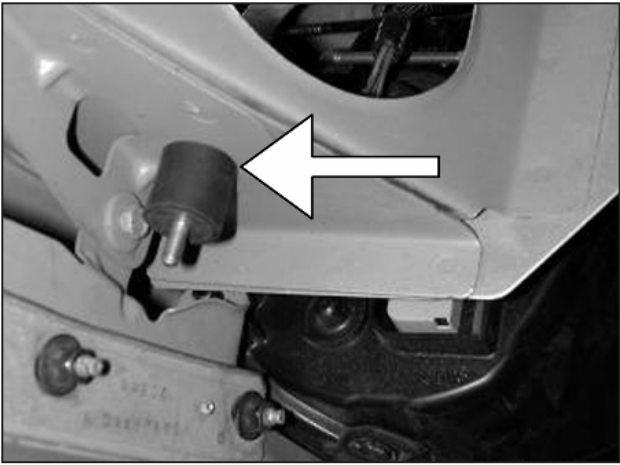

p. Locate this mounting hole inside the fender. Insert the 1" rubber mount.

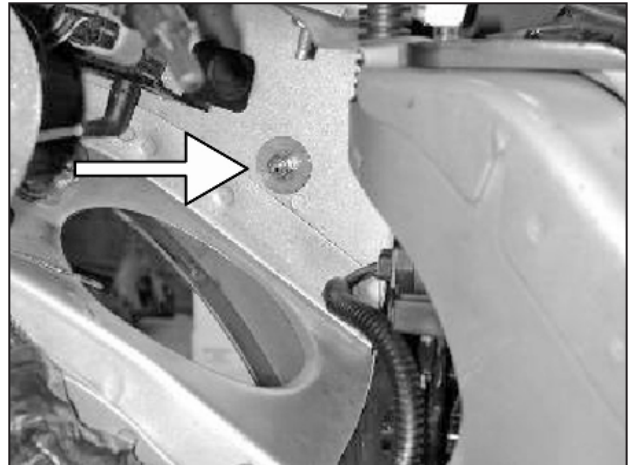

q. Secure the other side of the 1" rubber mount with the provided fender washer and nut.

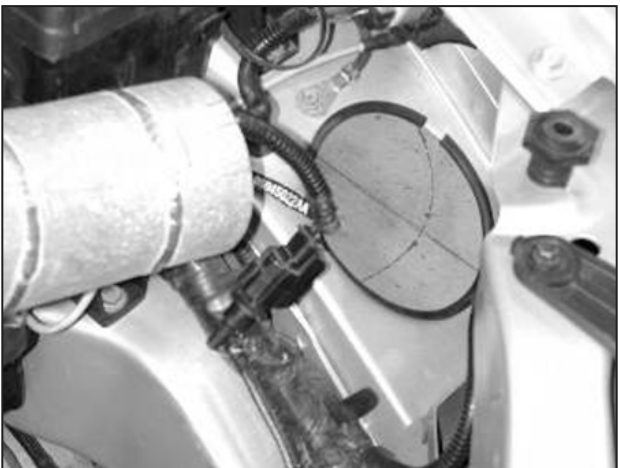

r. Attach the rubber edge trim to protect the lower pipe. Adhesive may be necessary.



s. Insert the rubber grommet into the small hole in the plastic lower intake pipe.



t. Attach the bracket for the plastic lower intake pipe with the provided hardware. Use two of the M6 hex/ flange bolts and lock washers.



u. Insert the lower pipe from inside the fender.

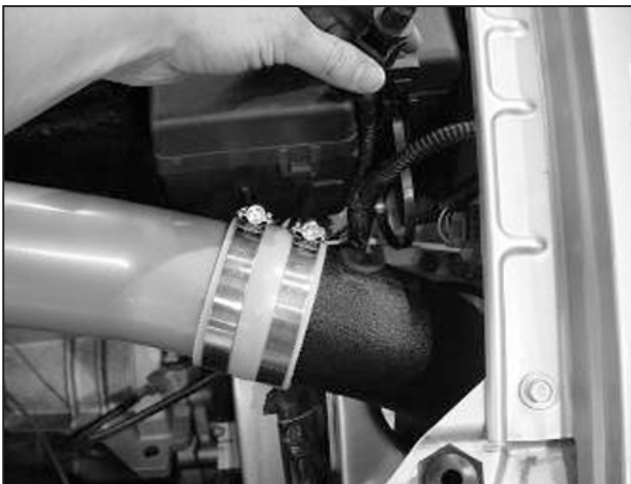

v. Attach the coupler and hose clamps. Make sure not to fully tighten the hose clamps. Make sure the IAT harness is clear.



w. Line up the bracket with the 1" rubber mount from the inner fender side.



x. Secure the bracket on the rubber mount with a washer and nut.



y. Carefully insert the IAT sensor into the rubber grommet on the lower intake pipe.



z. Attach the air filter element to the lower end of the intake pipe. Secure with the a hose clamp.



aa. Secure the upper inlet pipe to the 5/8" rubber mount on the battery tray. Check for clearance around the intake pipe.



ab. There should be adequate clearance around both upper and lower pipes around the battery.

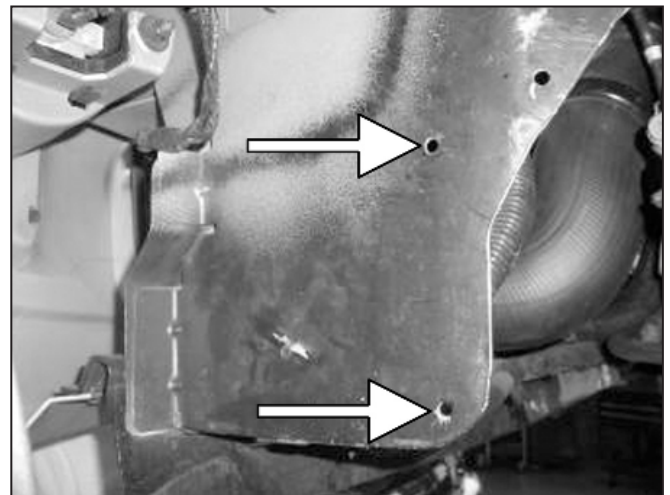

ac. Locate the two mounting holes in the fender.



ad. Secure the splashguard with the flange bolt, washers and nut. The fender liner will tuck inside the splashguard.

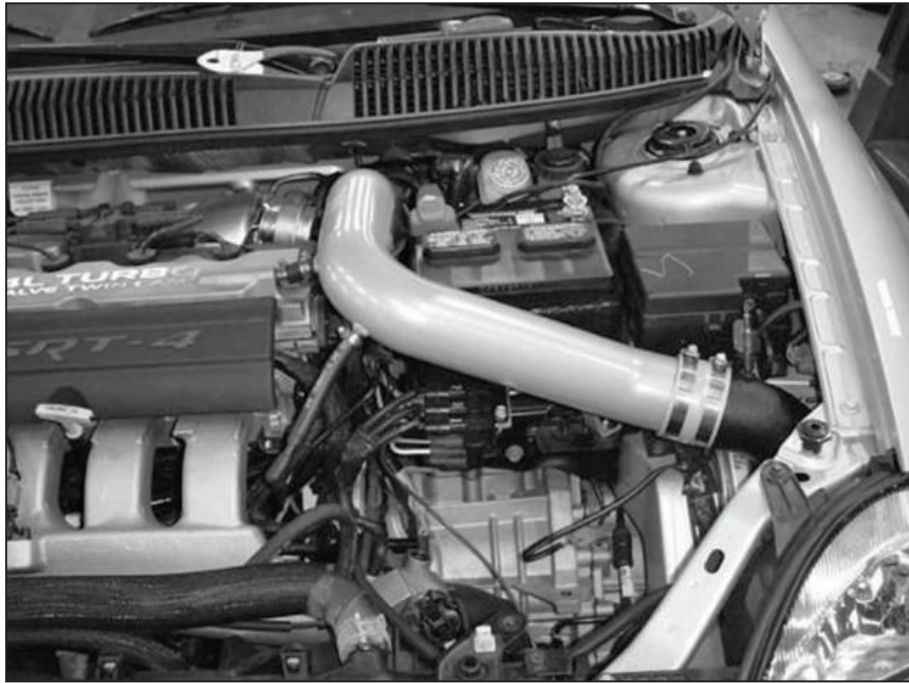

AEM® intake system installed

4. Reassemble Vehicle

- a. **Fender liner:** Install the fender liner and any hardware that was removed in steps 3n. through 3o.
NOTE: Failure to install the fender liner will result in diminished performance and increase the potential for engine damage due to water ingestion in rainy conditions.
- b. **Wheel:** Install the 3n side wheel using the factory torque specification (see owner's manual).
- c. Position the inlet pipes for the best fitment. Be sure that the pipes or any other components do not contact any part of the vehicle. Tighten the rubber mount, all bolts, and hose clamps.
- d. Check for proper hood clearance. Re-adjust pipes if necessary and re-tighten them.
- e. Inspect the engine bay for any loose tools and check that all fasteners that were moved or removed are properly tightened.
- f. Reconnect negative battery terminals and start engine. Let the vehicle idle for 3 minutes. Perform a final inspection before driving the vehicle.

5. CARB Sticker Placement

- a. The C.A.R.B. exemption sticker, (attached), must be visible under the hood so that an emissions inspector can see it when the vehicle is required to be tested for emissions. California requires testing every two years, other states may vary.

6. Service and Maintenance

- a. It is recommended that you service your AEM® Dryflow™ filter every 20,000 miles for optimum performance. Use AEM Dryflow cleaning kit part # 21-110.
- b. Use aluminum polish to clean your polished AEM® intake tube.
- c. Use window cleaner to clean your powder coated AEM® intake tube. **(NOTE: DO NOT USE aluminum polish on powder coated AEM intake tubes).**

For technical inquiries
e-mail us at
sales@aemintakes.com
or
call us at
800.992.3000

AEM Air Intake System Warranty Policy

AEM® warrants that its intake systems will last for the life of your vehicle. AEM will not honor this warranty due to mechanical damage (i.e. improper installation or fitment), damage from misuse, accidents or flying debris. AEM will not warrant its powder coating if the finish has been cleaned with a hydrocarbon-based solvent. The powder coating should only be cleaned with a mild soap and water solution. Proof of purchase of both the vehicle and AEM intake system is required for redemption of a warranty claim.

This warranty is limited to the repair or replacement of the AEM part. In no event shall this warranty exceed the original purchase price of the AEM part nor shall AEM be responsible for special, incidental or consequential damages or cost incurred due to the failure of this product. Warranty claims to AEM must be transportation prepaid and accompanied with dated proof of purchase. This warranty applies only to the original purchaser of product and is nontransferable. Improper use or installation, use for racing, accident, abuse, unauthorized repairs or alterations voids this warranty. AEM disclaims any liability for consequential damages due to breach of any written or implied warranty on all products manufactured by AEM. Warranty returns will only be accepted by AEM when accompanied by a valid Return Merchandise Authorization (RMA) number. Credit for defective products will be issued pending inspection. Product must be received by AEM within 30 days of the date RMA is issued.

If you have a warranty issue, please call (800) 992-3000 and our customer service department will assist you. A proof of purchase is required for all AEM warranty claims.

Intake systems for vehicles listed are 50 state legal. See AEMIntakes.com for CARB status on each part for a specific vehicle.