



Equipped with AEM® Dryflow™ Filter
No Oil Required!

INSTALLATION INSTRUCTIONS

PART NUMBER:

21-462B (Blue Finish)

21-462C (Gun Metal Grey Finish)

21-462P (Vacuum Metalized Chrome-VMC)

21-462R (Red Finish)

2000-2005 TOYOTA MR2 Spyder L4-1.8L C.A.R.B. E.O. # D-670-15

**Intake systems for vehicles listed are 50
state legal. See AEMIntakes.com for CARB
status on each part for a specific vehicle.**

PARTS LIST

Description	Qty.	Part Number
Element Parts Kit 2.50 X 5" Dry Ele.	1	21-201DK
Inlet Pipe	1	2-471
Elbow, 2.75" 90 Degree	1	30217
Hose; 1/2"ID X 18"L	1	5-5018
Mount, Rubber 1" X 6mm	1	1228599
Bolt, Hex M6 X 1.0 X 16mm	1	1-2030
Bolt, Socket 8-32 X 5/16 SS	2	1-2023
Nut, M6 Hex Serrated	3	444.460.04
Washer, 6mm Soft Mount	1	08160
1/2" Bnd. Hose Clamp, 2.31-3.25"	3	9444
Hose Clamp, 1"	2	08407

Read and understand these instructions BEFORE attempting to install this product. Failure to follow installation instructions and not using the provided hardware may damage the intake tube, throttle body and engine.

The AEM[®] intake system is a performance product that can be used safely during mild weather conditions. During harsh and inclement weather conditions, you must return your vehicle to stock OEM air box and intake tract configuration. Failure to follow these instructions will void your warranty.

1. Preparing Vehicle

- a. Make sure vehicle is parked on level surface.
- b. Set parking brake.
- c. If engine has run in the past two hours, let it cool down.
- d. Disconnect negative battery terminal.
- e. Raise the front of the vehicle with a jack. Refer to your owner's manual for proper jack and jack stand placement to properly support vehicle. Support your vehicle using properly rated jack stands before wheel removal or while working under the vehicle.

NEVER WORK UNDER A VEHICLE WITHOUT USING JACK STANDS.

- f. Do not discard stock components after removal of the factory system.

2. Removing the rear suspension upper brace.

- a. Loosen the two nuts and two bolts securing the rear suspension upper brace. Remove the rear suspension upper brace from the car and set aside in a safe place.

3. Removing the rear bumper cover. (This step may require two people)

- a. Remove the taillights by loosening the two bolts on each light assembly and disconnecting the wire connector. Set the taillights aside in a safe place.
- b. Remove the license plate and license plate frame.
- c. Remove the bolts on the underside of the bumper that attach the bumper cover to the rear engine under cover. Allow the rear engine under cover to hang freely.
- d. Remove the bolt from inside the wheel well, one on each side. **(Fig. 1)**
- e. Remove the bumper cover bolts in the taillight openings, two on each side. **(Fig. 2)**
- f. Remove clips from the top edge of the bumper cover.
- g. Put a blanket under the bumper cover to protect the paint.
- h. Pull back the bumper cover far enough to allow access to the license plate lights. Remove the license plate lights from the bumper cover by twisting the socket counter-clockwise and pulling the socket from the bumper cover.

NOTE: BE CAREFUL NOT TO LET THE BUMPER COVER FALL BEFORE REMOVING THE LICENSE PLATE LIGHTS.

- i. Guide the sides of the bumper cover around the wheel well splashguards and remove bumper cover from vehicle. Set the bumper cover aside in a safe place.

4. Removal of stock system

- a. There are two Vacuum Switching Valves (VSV), and one air flow meter that have electrical and/or vacuum connections going to them. Be sure to label these connections before disconnecting them. Refer to the diagram on pages 5 for the identification of these components. **(Fig.3)**
- b. Remove the air flow meter connector, and then remove the air flow meter by loosening the two Phillips screws. Be extremely careful with this component as it can be damaged easily. Set the air flow meter aside

in a safe place.

- c. Disconnect the wire connector and the two vacuum lines from the Vacuum Switching Valve (VSV) for EVAP on the stock intake air hose. Loosen the hose clamp at the throttle body end of the intake air hose.
- d. Disconnect and remove the vacuum line between the VSV for Canister Closed Valve (CCV) and the stock inlet tube. Disconnect the vacuum line between the VSV for CCV and the metal hard line. This hose will be reused during the installation of the AEM[®] intake system. Remove the wire connector from the VSV for the CCV.
- e. Release the two clips on the front side of air cleaner cap assembly. Pull the air cleaner cap assembly and the intake air hose out of the vehicle with the two VSV 's still attached.
- f. Remove the bolt holding the air cleaner lower case in place. Remove the plastic screw on the inlet tube located under the radiator overflow tank. **(Fig. 4)** Remove the air cleaner lower case assembly.
- g. Remove the VSV for EVAP from the stock intake air hose by pulling the metal bracket out of the plastic intake air hose. Remove the VSV for CCV from the air cleaner cap assembly by removing the mounting bolt. **(Fig. 5)** Set these components aside in a safe place.

5. Installation of AEM[®] intake system.

- a. When installing the intake system, do not completely tighten the hose clamps or mounting hardware until instructed to do so.
- b. Install the 90 degree elbow coupling onto the throttle body with the two hose clamps.
- c. Thread one end of the rubber mount into the underside of the rear core support. Use the hole that was originally used for the bumper cover mounting screw. **(Fig. 6)**
- d. Check and ensure that the inside of the AEM[®] intake pipe and air filter are clean and free from any foreign objects and/or obstructions.
- e. Feed the intake pipe up into the engine compartment from the rear of the vehicle. The throttle body end of the intake pipe is the end with the air flow meter adapter. **(Fig. 7)**
- f. Insert the intake pipe into the 90 degree coupling on the throttle body.
- g. Install the washer and retaining nut onto the rubber mount stud but do not tighten.

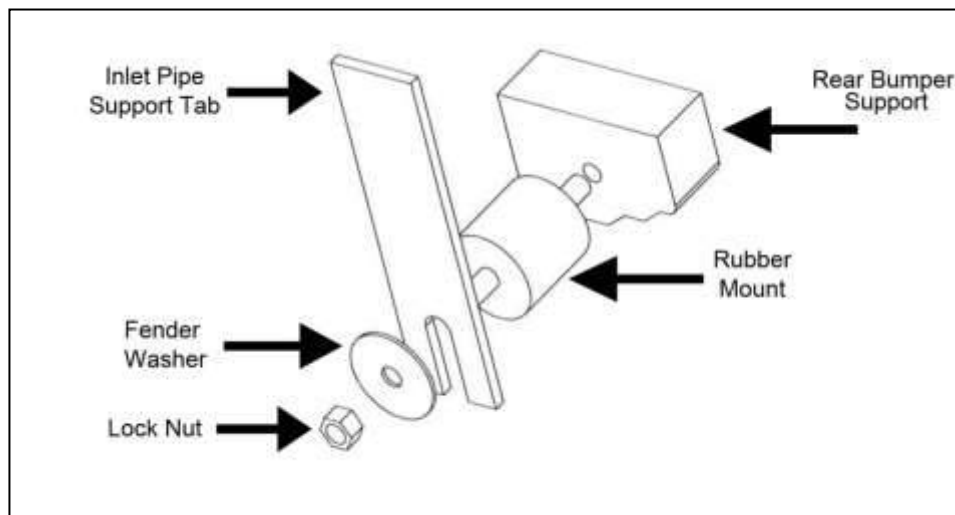

- h. Install the AEM[®] air filter onto the end of the intake pipe. Push the air filter on around 2 inches over the intake pipe and install one hose clamp to secure the air filter onto the intake pipe. Once fitment is checked, you can either push the air filter onto the intake pipe more or less depending on clearances. Tighten the hose clamp after this is done.
- i. Mount the VSV for CCV onto the mounting tab on the AEM[®] intake pipe using the supplied M6 bolt and nut. Run the 18" section of vacuum hose, supplied in the kit, between the bottom of the VSV for CCV and the

nipple on the intake pipe. **(Fig. 8)** Secure both ends of the vacuum hose with hose clamps. Reconnect the vacuum line between the VSV for CCV and metal hard line removed in step 4d. Reconnect the VSV for CCV wire connector.

- j. Using a very small amount of lubricant on the o-ring, install the air flow meter into the inlet pipe, then reconnect the air flow meter connector. Use the two M4 bolts that are supplied in the kit to secure the air flow meter. Be sure that the o-ring on the air flow meter is seated correctly in the air flow meter adapter. **NOTE: BE CAREFUL DO NOT OVER TORQUE THESE BOLTS.**
- k. Mount the VSV for EVAP and bracket to the mount on the AEM® intake pipe using the M6 bolt that was originally used to hold the bumper cover on. This bolt has been replaced with the supplied rubber mount and nut. Reconnect the two VSV for EVAP vacuum lines and wire connector. **(Fig. 9)**
- l. Position the intake pipe for best fitment. Be sure that the intake pipe or any other components do not contact any part of the vehicle. Tighten the hose clamps at the throttle body and then tighten the nut on the rubber mount.

Reference Diagrams:



Fig. 1

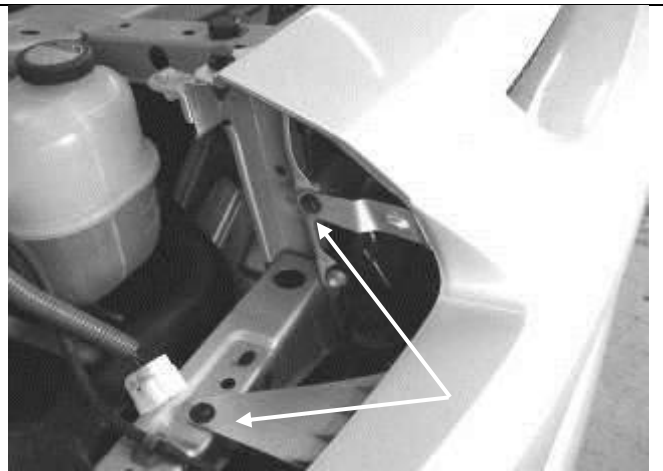

Fig. 2

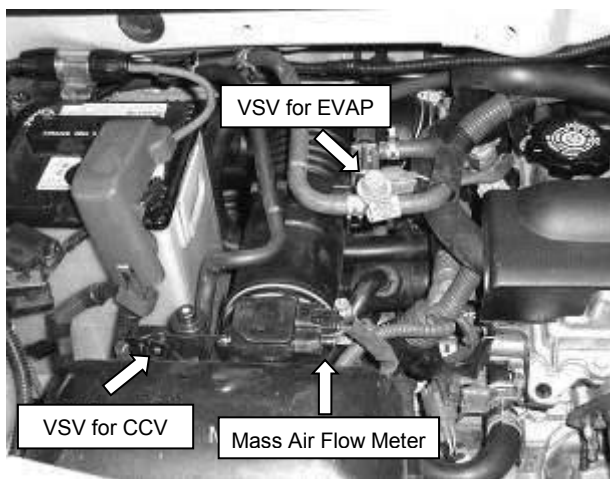

Fig. 3



Fig. 4

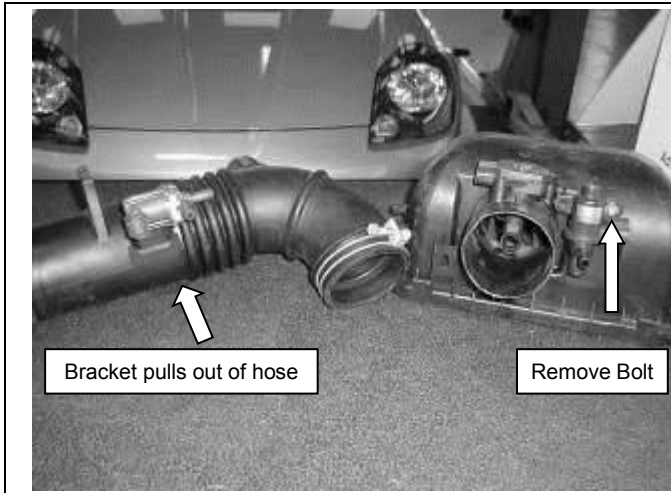

Fig. 5

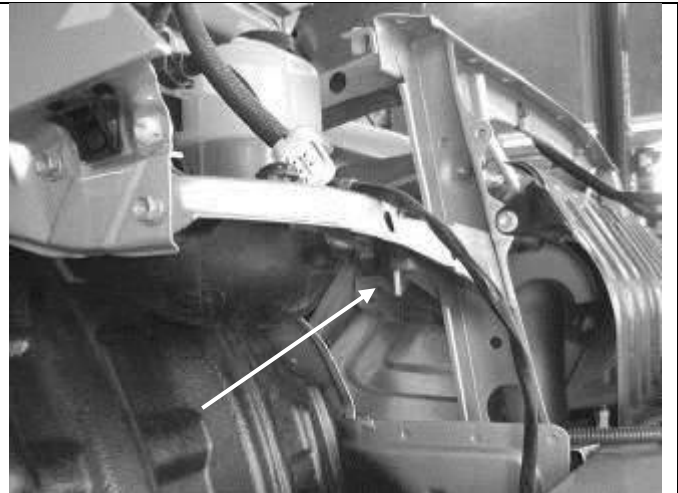

Fig. 6: Installation of rubber mount

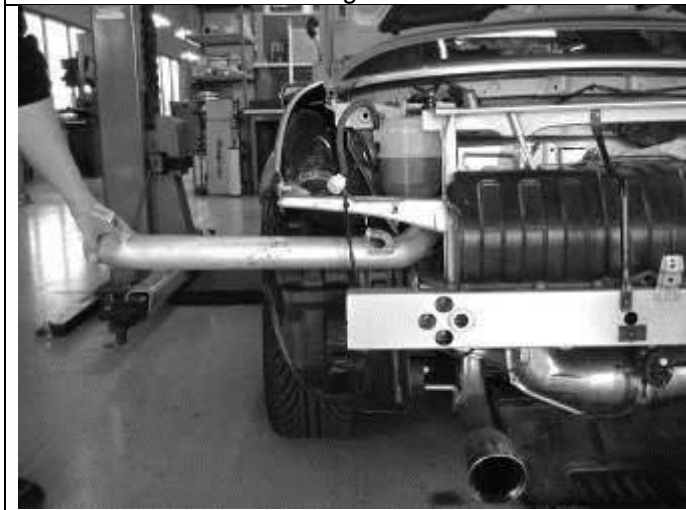

Fig. 7

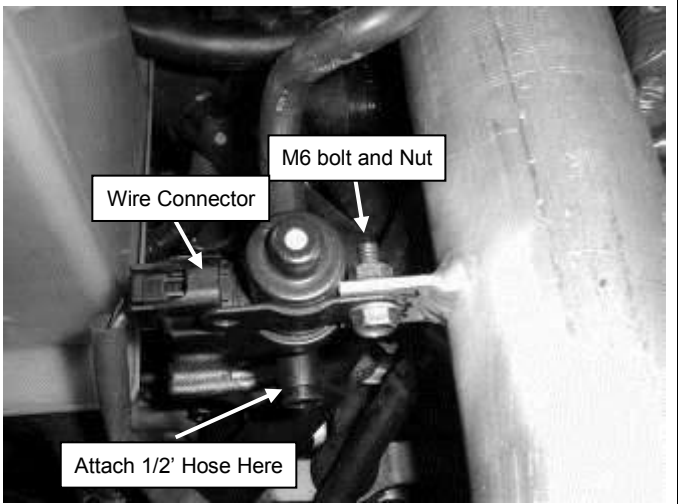

Fig. 8: Installation of the VSV for CCV

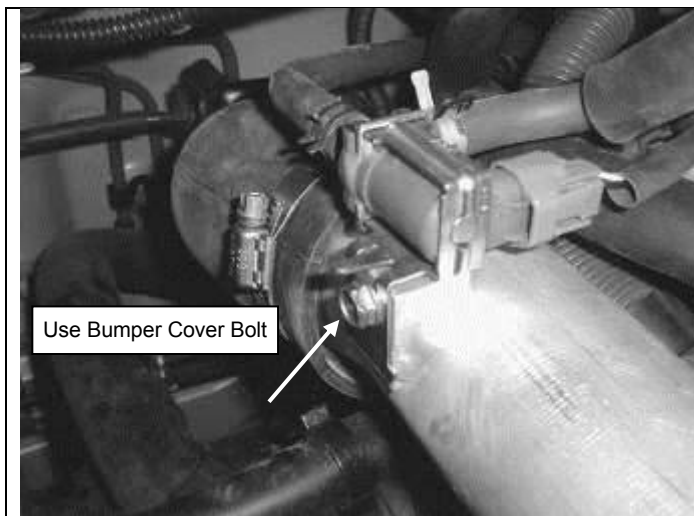
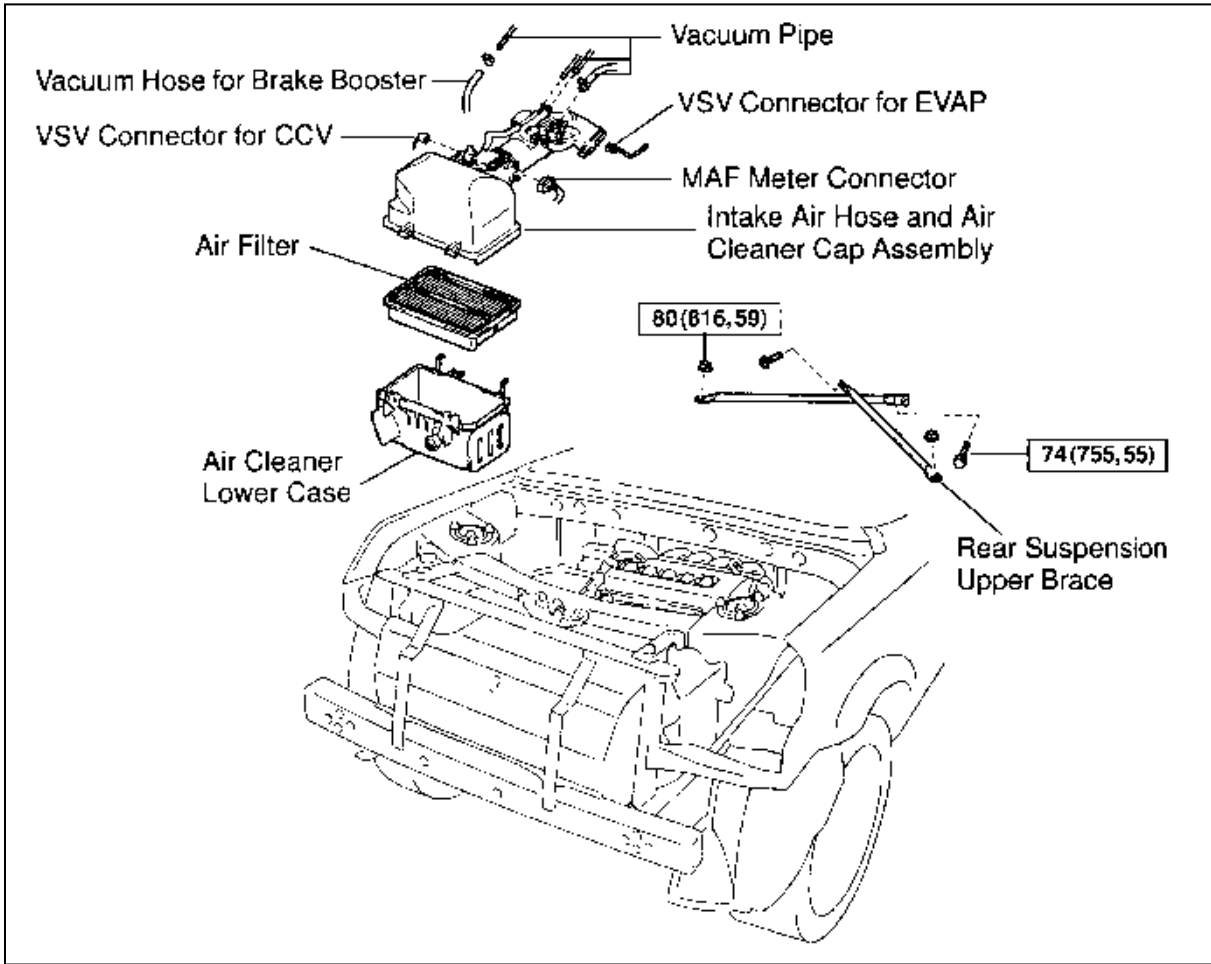
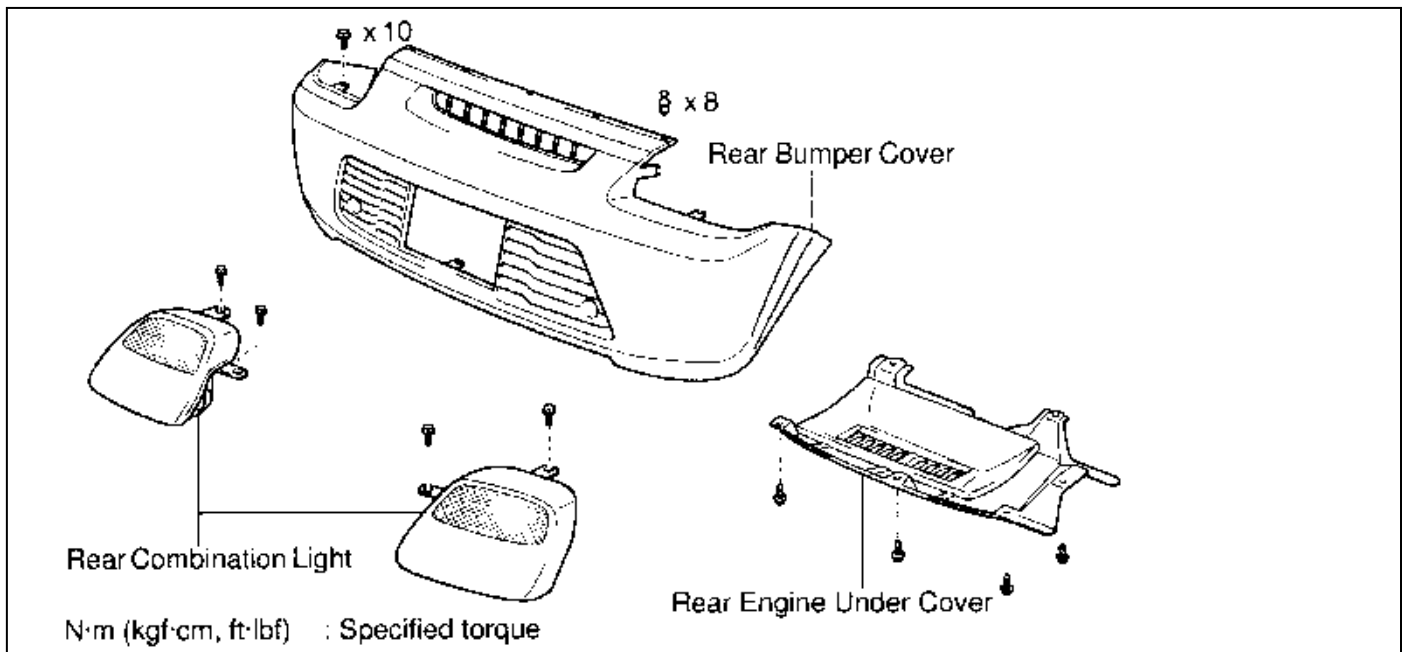

Fig. 9: Installation of the VSV for EVAP



Fig. 10





6. Reassemble Vehicle

- Bumper and taillights:** Install bumper cover and taillights in reverse order of removal. Use the supplied M6 nut to secure the bumper cover to the exposed stud of the rubber mount. **(Fig. 10)**
- Rear suspension upper brace:** Install the rear suspension upper brace that was removed in step 2a.
- Position the inlet pipes for the best fitment. Be sure that the pipes or any other components do not contact any part of the vehicle. Tighten the rubber mount, all bolts, and hose clamps.
- Check for proper hood clearance. Re-adjust pipes if necessary and re-tighten them.
- Inspect the engine bay for any loose tools and check that all fasteners that were moved or removed are properly tightened.
- Reconnect negative battery terminals and start engine. Let the vehicle idle for 3 minutes. Perform a final inspection before driving the vehicle.

NOTE: If vehicle was started without one of the VSV's or the air flow meter connected then the "Check Engine" light may come on. If this happens turn the engine off and disconnect the battery for one minute. Reconnect the battery and restart the engine.

7. CARB Sticker Placement

- The C.A.R.B. exemption sticker, (attached), must be visible under the hood so that an emissions inspector can see it when the vehicle is required to be tested for emissions. California requires testing every two years, other states may vary.

8. Service and Maintenance

- It is recommended that you service your AEM® Dryflow™ filter every 20,000 miles for optimum performance. Use AEM Dryflow cleaning kit part # 21-110.
- Use aluminum polish to clean your polished AEM® intake tube.
- Use window cleaner to clean your powder coated AEM® intake tube. **(NOTE: DO NOT USE aluminum polish on powder coated AEM intake tubes).**

For technical inquiries
e-mail us at
sales@aemintakes.com
or
call us at
800.992.3000

AEM Air Intake System Warranty Policy

AEM® warrants that its intake systems will last for the life of your vehicle. AEM will not honor this warranty due to mechanical damage (i.e. improper installation or fitment), damage from misuse, accidents or flying debris. AEM will not warrant its powder coating if the finish has been cleaned with a hydrocarbon-based solvent. The powder coating should only be cleaned with a mild soap and water solution. Proof of purchase of both the vehicle and AEM intake system is required for redemption of a warranty claim.

This warranty is limited to the repair or replacement of the AEM part. In no event shall this warranty exceed the original purchase price of the AEM part nor shall AEM be responsible for special, incidental or consequential damages or cost incurred due to the failure of this product. Warranty claims to AEM must be transportation prepaid and accompanied with dated proof of purchase. This warranty applies only to the original purchaser of product and is nontransferable. Improper use or installation, use for racing, accident, abuse, unauthorized repairs or alterations voids this warranty. AEM disclaims any liability for consequential damages due to breach of any written or implied warranty on all products manufactured by AEM. Warranty returns will only be accepted by AEM when accompanied by a valid Return Merchandise Authorization (RMA) number. Credit for defective products will be issued pending inspection. Product must be received by AEM within 30 days of the date RMA is issued.

If you have a warranty issue, please call (800) 992-3000 and our customer service department will assist you. A proof of purchase is required for all AEM warranty claims.

Intake systems for vehicles listed are 50 state legal. See AEMIntakes.com for CARB status on each part for a specific vehicle.