



Equipped with AEM® Dryflow™ Filter
No Oil Required!

INSTALLATION INSTRUCTIONS

PART NUMBER:

21-504B (Blue Finish)

21-504C (Gun Metal Grey Finish)

21-504P (Vacuum Metalized Chrome-VMC)

21-504R (Red Finish)

2000-2003 HONDA S2000 L4-2.0L

C.A.R.B. E.O. # D-670-15

**Intake systems for vehicles listed are 50
state legal. See AEMIntakes.com for CARB
status on each part for a specific vehicle.**

PARTS LIST

Description	Qty.	Part Number
Element Parts Kit 3.00 X 5" Dry Ele.	1	21-203DK
Upper Pipe	1	2-483
Lower Pipe	1	2-484
Hose; 5/16ID X 12"L	1	5-2012
Hose, Adapter 2.75/3.00 X 3" Bl.	1	5-273
Hose, Silicone 3.00x3" Blk.	1	5-300
Hose; 1/2"ID X 12"L	1	5-5012
Hose; 5/32"ID X 30"L	1	5-3030
Mount, Rubber 1" X 6mm	1	1228599
Drain Valve, 0.500"	1	8-145
Washer, 6mm Soft Mount	2	08160
Nut, M6 Hex Serrated	2	444.460.04
1/2" Bnd. Hose Clamp, 2.31-3.25"	1	9444
1/2" Bnd. Hose Clamp, 2.56"-3.50"	3	9448
Hose Clamp, 1"	2	08407
1/2" Bnd. Hose Clamp, 2.90"-3.75"	1	9452

Read and understand these instructions **BEFORE** attempting to install this product. Failure to follow installation instructions and not using the provided hardware may damage the intake tube, throttle body and engine.

The AEM[®] intake system is a performance product that can be used safely during mild weather conditions. During harsh and inclement weather conditions, you must return your vehicle to stock OEM air box and intake tract configuration. Failure to follow these instructions will void your warranty.

1. Preparing Vehicle

- a. Make sure vehicle is parked on level surface.
- b. Set parking brake.
- c. If engine has run in the past two hours, let it cool down.
- d. Disconnect negative battery terminal.
- e. Do not discard stock components after removal of the factory system.

2. Removal of stock system

- a. Disconnect the Air Control Solenoid Valve Connector (A), then remove the vacuum hoses (B), loosen the throttle body hose clamp, loosen the three mounting bolts, and remove the air cleaner housing/intake duct (C) assembly. **(Fig. 1)**
- b. Raise the front of the vehicle with a jack. Refer to your owner's manual for proper jack and jack stand placement to properly support vehicle. Support your vehicle using properly rated jack stands before wheel removal or while working under the vehicle.

NEVER WORK UNDER A VEHICLE WITHOUT USING JACK STANDS.

- i. Remove the plastic under trays, and loosen the passenger side fender liner, as shown. **(Fig. 2)**
- c. **CAUTION: Ensure the engine is completely cool before removing the coolant hose, or hot coolant will escape from the cooling system and cause injury or damage. Be sure to capture any lost coolant in a clean container.**

Remove the metal tubing loom, which will include the breather hose, coolant hose and air control solenoid valve vacuum hoses. Make sure to note proper hose routing. (Place a rag under the loom, as coolant will leak from the lower hose) **(Fig. 3)**

3. Installation of AEM[®] intake system.

- a. When installing the intake system, do not completely tighten the hose clamps or mounting hardware until instructed to do so.
- b. Install the provided 5/16" hose between the throttle body and the bleeder outlet vacated by the removal of lower hose of the metal tube loom. Secure the 5/16" hose with the factory hose clamps, as shown. **(Fig. 4)**
NOTE: Replace any coolant recovered during hose removal by replenishing the recovery tank.
- c. Secure the small end of the provided rubber reducer coupler onto the throttle body with the provided No. 44 clamp. **(Fig.5)**
- d. Install the upper inlet pipe onto the coupler, and secure with a No. 48 clamp provided. **(Fig. 5)**
- e. Install the 1/2" breather hose to the cam cover and the nipple on the upper inlet pipe using the provided 1" hose clamps. **(Fig. 5)**
- f. Secure the factory 3/4" breather hose to the nipple on the upper inlet pipe with the factory clamp. **(Fig. 5)**
- g. Replace the factory Air Control Solenoid Valve vacuum lines with the supplied 1/8" lines, as shown. **(Fig. 6)**
- h. Using the factory bolt, secure the Air Control Solenoid Valve to the bracket on the upper cold air pipe as shown. **(Fig. 7)**
- i. Bolt the included rubber isolator mount to the chassis with the supplied washer and nylock nut, as shown.

- j. Trim the inner fender liner for tube clearance, as shown. **(Fig. 8)**
- k. Install the duck bill drain into the ½” hole in the lower intake pipe.
- l. Using the supplied 3” coupler and two No. 48 clamps, install the lower inlet pipe onto the upper pipe with the mounting bracket on top of the rubber isolator. **(Fig. 9)**
- m. Secure the lower inlet pipe to the rubber isolator with the supplied washer and nylock nut.
- n. Install the air filter on the end of the lower inlet pipe using the included No. 48 clamp. **(Fig. 10)**
- o. Check the intake system for clearance, tightening all fasteners ensuring the intake pipe does not touch the frame or radiator.
- p. For optimum performance, trim the passenger side under tray as shown to provide colder air to the filter element. **(Fig.11)**

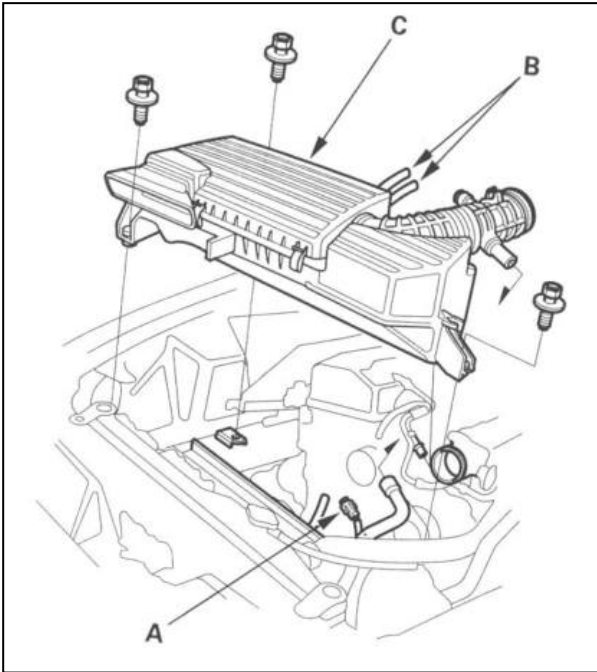

Fig.1

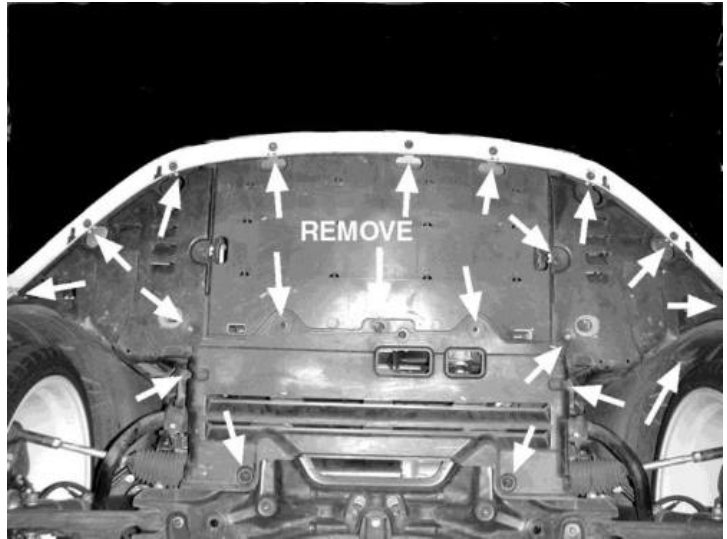

Fig.2

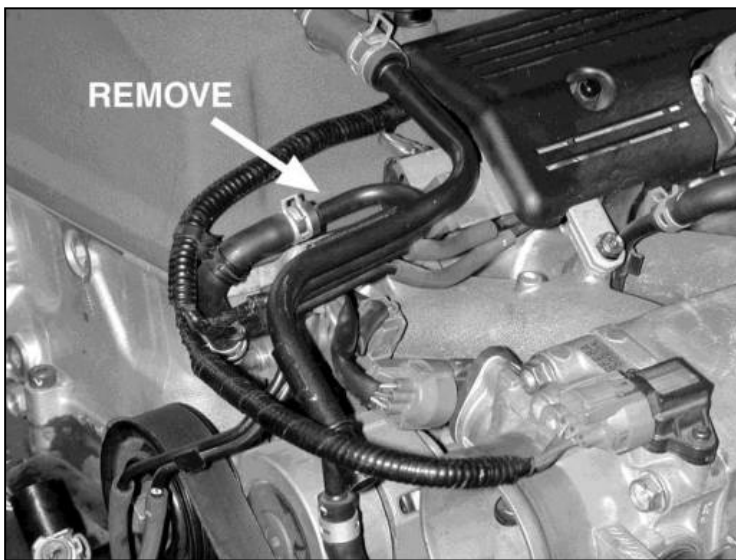

Fig.3

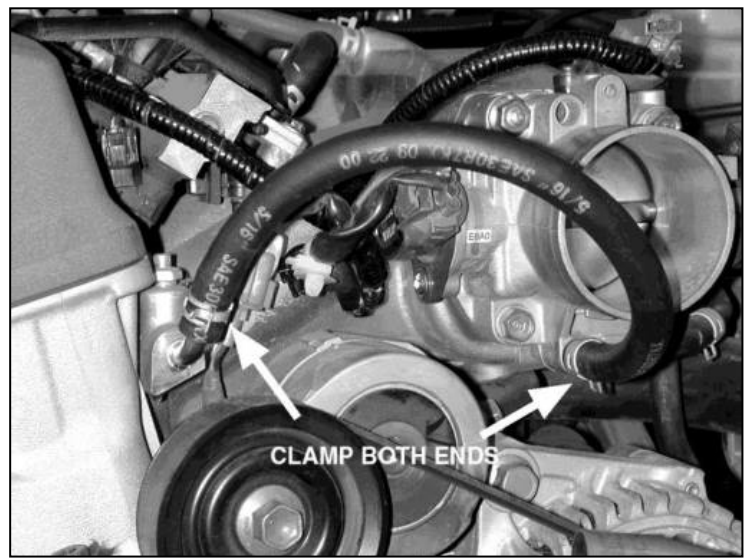

Fig.4

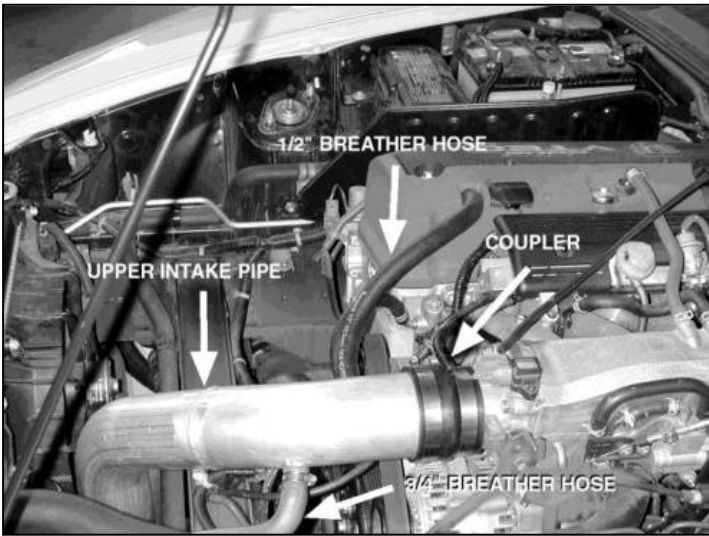

Fig.5

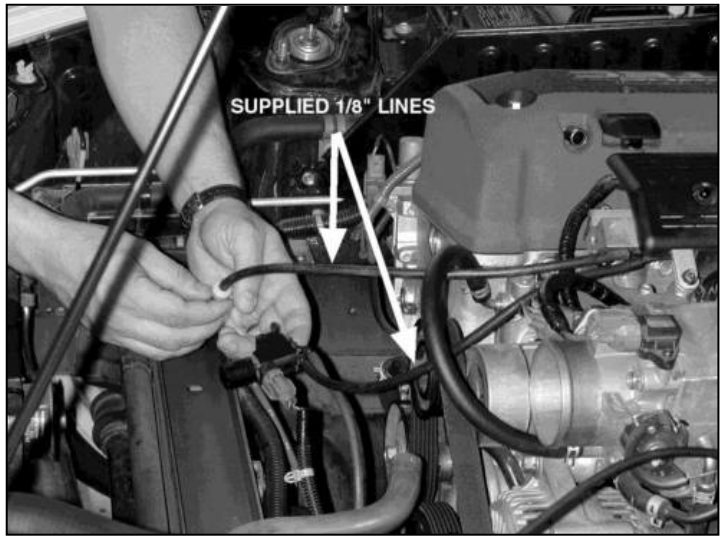

Fig.6

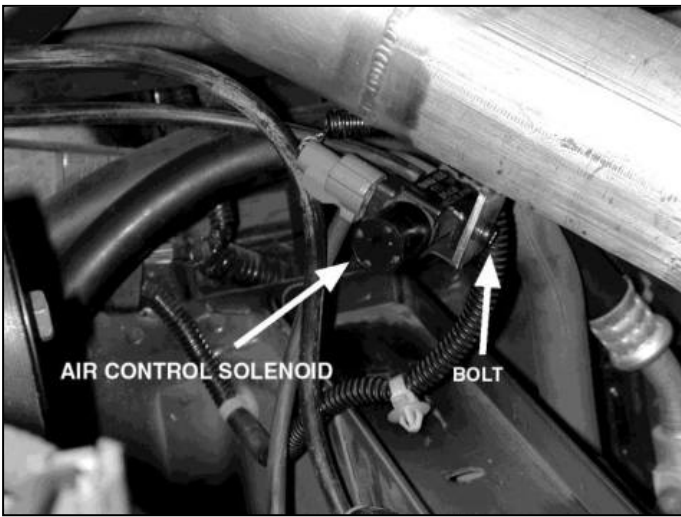

Fig.7

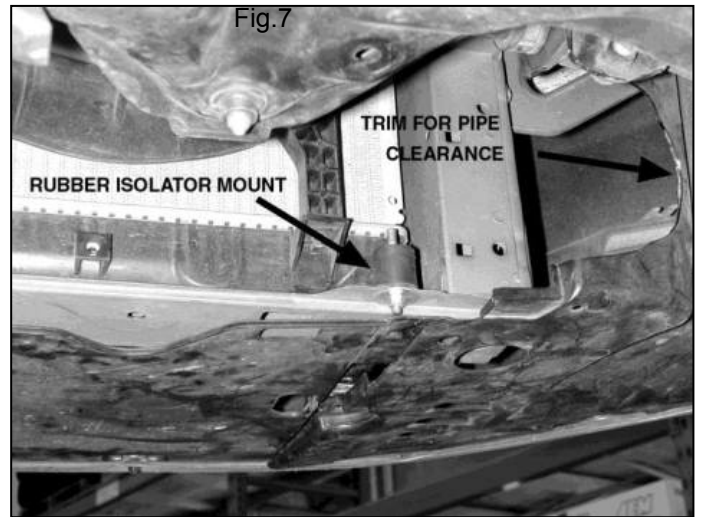

Fig.8

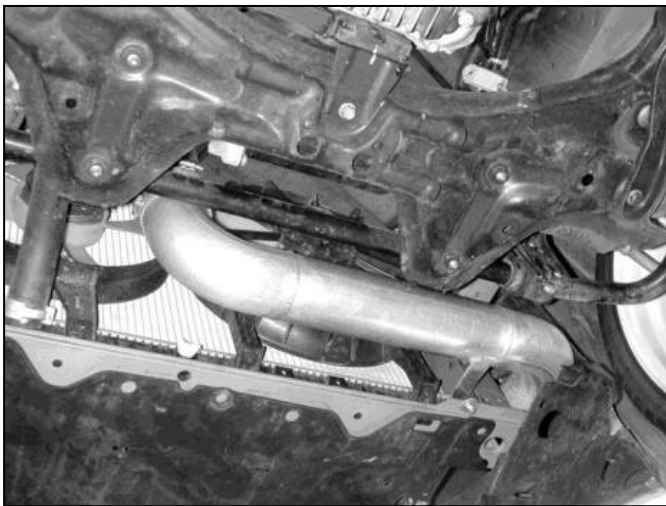

Fig.9

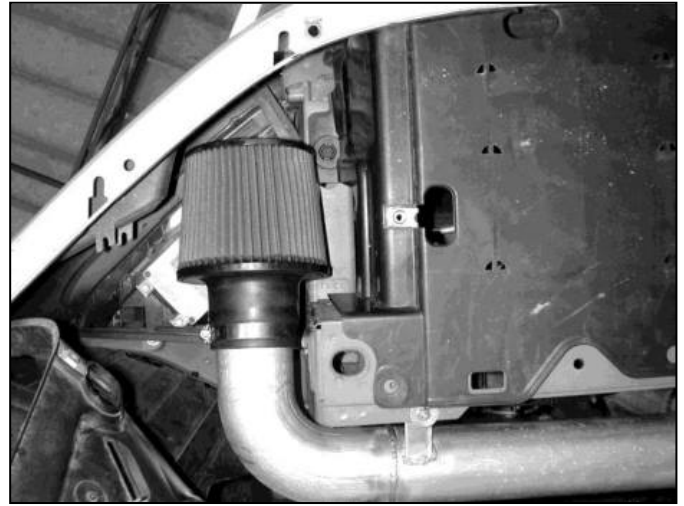

Fig.10

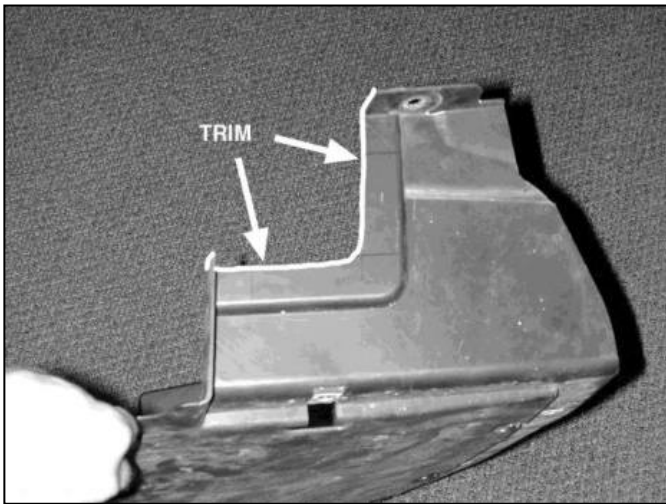

Fig.11

4. Reassemble Vehicle

- a. **Fender liner and lower front splashguard:** Install the fender liner, lower splashguard and any hardware that was removed in steps 2bi.
 - i. Reinstall the under trays, trimming or notching them for tube clearance where required.
 - ii. Reinstall the inner fender liner fasteners.
- b. Position the inlet pipes for the best fitment. Be sure that the pipes or any other components do not contact any part of the vehicle. Tighten the rubber mount, all bolts, and hose clamps.
- c. Check for proper hood clearance. Re-adjust pipes if necessary and re-tighten them.
- d. Inspect the engine bay for any loose tools and check that all fasteners that were moved or removed are properly tightened.
- e. Reconnect negative battery terminals and start engine. Let the vehicle idle for 3 minutes. Perform a final inspection before driving the vehicle.

5. CARB Sticker Placement

- a. The C.A.R.B. exemption sticker, (attached), must be visible under the hood so that an emissions inspector can see it when the vehicle is required to be tested for emissions. California requires testing every two years, other states may vary.

6. Service and Maintenance

- a. It is recommended that you service your AEM[®] Dryflow[™] filter every 20,000 miles for optimum performance. Use AEM Dryflow cleaning kit part # 21-110.
- b. Use aluminum polish to clean your polished AEM[®] intake tube.
- c. Use window cleaner to clean your powder coated AEM[®] intake tube. **(NOTE: DO NOT USE aluminum polish on powder coated AEM intake tubes).**

For technical inquiries
e-mail us at
sales@aemintakes.com
or
call us at
800.992.3000

AEM Air Intake System Warranty Policy

AEM® warrants that its intake systems will last for the life of your vehicle. AEM will not honor this warranty due to mechanical damage (i.e. improper installation or fitment), damage from misuse, accidents or flying debris. AEM will not warrant its powder coating if the finish has been cleaned with a hydrocarbon-based solvent. The powder coating should only be cleaned with a mild soap and water solution. Proof of purchase of both the vehicle and AEM intake system is required for redemption of a warranty claim.

This warranty is limited to the repair or replacement of the AEM part. In no event shall this warranty exceed the original purchase price of the AEM part nor shall AEM be responsible for special, incidental or consequential damages or cost incurred due to the failure of this product. Warranty claims to AEM must be transportation prepaid and accompanied with dated proof of purchase. This warranty applies only to the original purchaser of product and is nontransferable. Improper use or installation, use for racing, accident, abuse, unauthorized repairs or alterations voids this warranty. AEM disclaims any liability for consequential damages due to breach of any written or implied warranty on all products manufactured by AEM. Warranty returns will only be accepted by AEM when accompanied by a valid Return Merchandise Authorization (RMA) number. Credit for defective products will be issued pending inspection. Product must be received by AEM within 30 days of the date RMA is issued.

If you have a warranty issue, please call (800) 992-3000 and our customer service department will assist you. A proof of purchase is required for all AEM warranty claims.

**Intake systems for vehicles listed are 50
state legal. See AEMIntakes.com for CARB
status on each part for a specific vehicle.**