



Equipped with AEM® Dryflow™ Filter  
No Oil Required!

## **INSTALLATION INSTRUCTIONS**

**PART NUMBER:**

**21-514B (Blue Finish)**

**21-514C (Gun Metal Grey Finish)**

**21-514P (Vacuum Metalized Chrome-VMC)**

**21-514R (Red Finish)**

---

2004-2005 HONDA S2000 L4-2.2L

C.A.R.B. E.O. # D-670-15

**Intake systems for vehicles listed are 50  
state legal. See [AEMIntakes.com](http://AEMIntakes.com) for CARB  
status on each part for a specific vehicle.**

## PARTS LIST

Description	Qty.	Part Number
Air Filter Assy. 3.25 X 5" Dry Ele.	1	21-2110DK
Upper Pipe	1	2-569
Lower Pipe	1	2-570
Hose, Adapter 3.25/3.00 X 2.25"	1	5-323
Hose; 5/16ID X 12"L	1	5-2012
Hose, Silicone 3.25x3.0"	1	5-325
Hose; 1/2"ID X 12"L	1	5-5012
Hose; 5/32"ID X 30"L	1	5-3030
Mount, Rubber 1" X 6mm	1	1228599
Drain Valve, 0.500"	1	8-145
Washer, 6mm Soft Mount	2	08160
Nut, M6 Hex Serrated	2	444.460.04
1/2" Bnd. Hose Clamp, 2.31-3.25"	1	9444
1/2" Bnd Hose Clamp, 2.56"-3.50"	3	9448
Hose Clamp, 1"	1	08407
1/2" Bnd. Hose Clamp, 3.15"-4.00"	1	9456

Read and understand these instructions BEFORE attempting to install this product. Failure to follow installation instructions and not using the provided hardware may damage the intake tube, throttle body and engine.

The AEM® intake system is a performance product that can be used safely during mild weather conditions. During harsh and inclement weather conditions, you must return your vehicle to stock OEM air box and intake tract configuration. Failure to follow these instructions will void your warranty.

### 1. Preparing Vehicle

- a. Make sure vehicle is parked on level surface.
- b. Set parking brake.
- c. If engine has run in the past two hours, let it cool down.
- d. Disconnect negative battery terminal.
- e. Do not discard stock components after removal of the factory system.

### 2. Removal of stock system



a. There is one breather hose, one vacuum hose, and one Air Control Solenoid.

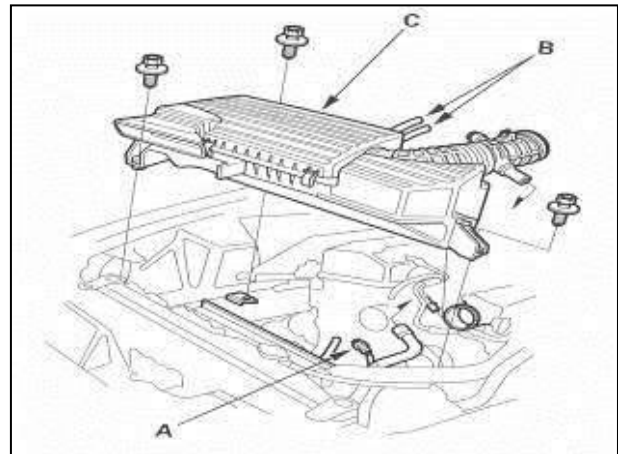

b. Disconnect the Air Control Solenoid Valve Connector (A) and then remove the vacuum hoses (B).

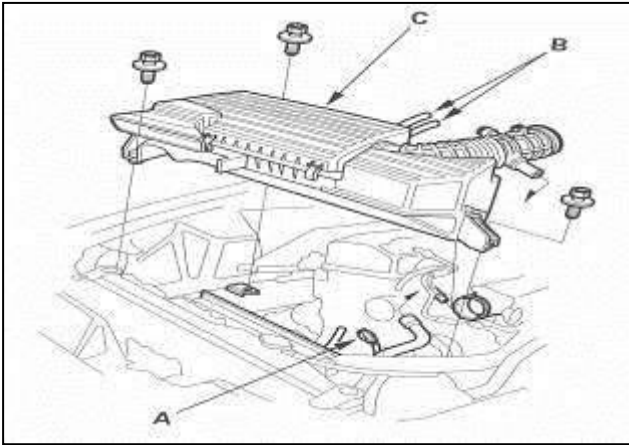

c. Loosen the throttle body hose clamp, loosen the three mounting bolts, and remove the air cleaner housing/intake duct (C) assembly.

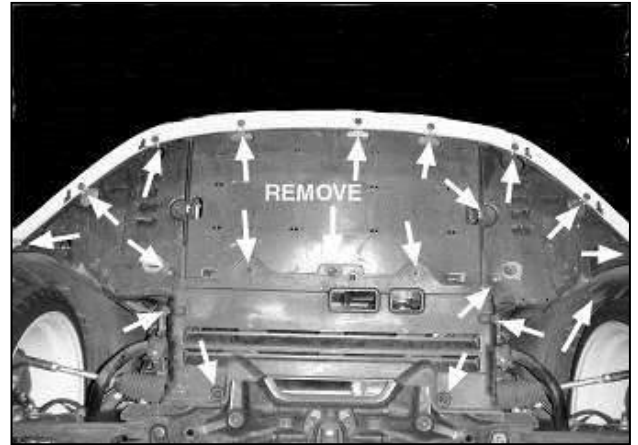

d. Raise the front of the vehicle with a jack. Refer to your owner's manual for proper jack and jack stand placement to properly support vehicle. Support your vehicle using properly rated jack stands before wheel removal or while working under the vehicle.  
**NEVER WORK UNDER A VEHICLE WITHOUT USING JACK STANDS.**  
 Remove the front passenger side wheel. Remove the plastic under trays, and loosen the passenger side inner fender liner as shown.

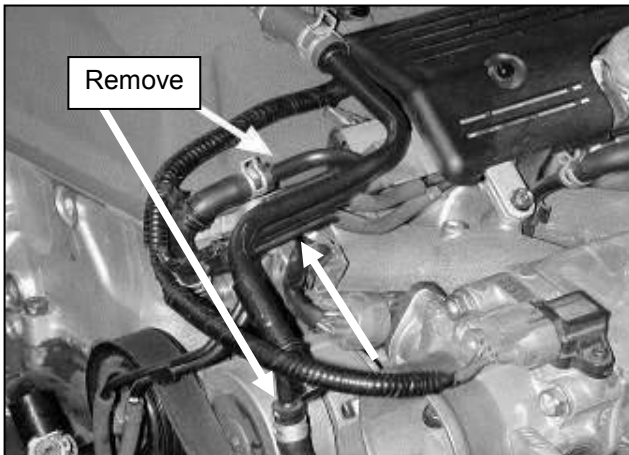

e. **CAUTION: Ensure the engine is completely cool before removing the coolant hose, or hot coolant will escape from the cooling system and cause injury or damage. Be sure to capture any lost coolant in a clean container.** Remove the metal tubing loom, which will include the breather hose, coolant hose and air control solenoid valve vacuum hoses. Make sure to note proper hose routing (Place the clean catch container under the loom, as coolant will leak from the lower hose).

### 3. Installation of AEM® intake system.

- a. When installing the intake system, do not completely tighten the hose clamps or mounting hardware until instructed to do so.

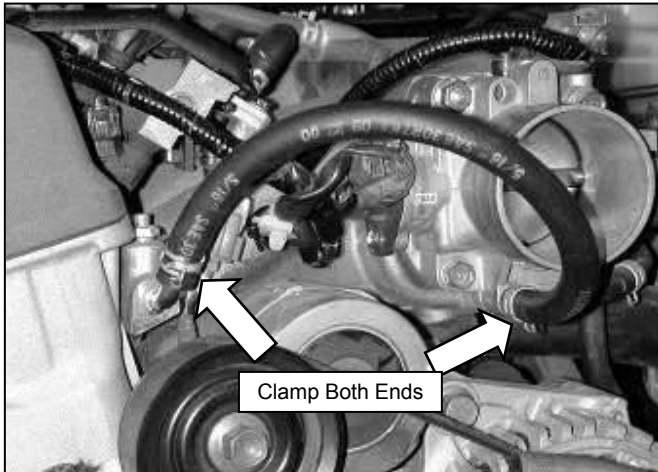

- b. Install the provided 5/16" hose between the throttle body and the bleeder outlet vacated by the removal of lower hose of the metal tube loom. Use the factory hose clamps as shown.

**NOTE: Replace any coolant recovered during hose removal by replenishing the recovery tank.**

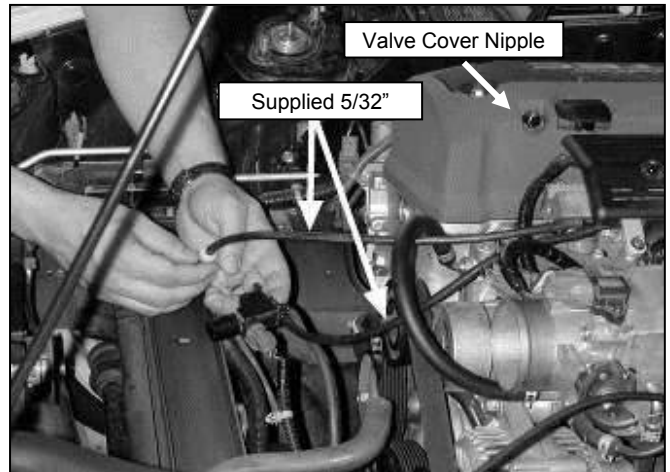

- c. Replace the factory Air Control Solenoid Valve vacuum lines with the supplied 5/32" lines, as shown. Use the two supplied zip ties to zip tie the hoses away from the serpentine belt. Install the supplied breather hose onto the valve cover nipple using the supplied hose clamps.



- d. Install the 3.00"-3.25" reducing coupler on to the throttle body using the #44 hose clamp. Ensure that the inside of the AEM® intake pipes and air filter are clean and free from any foreign objects and/or obstructions.



- e. Using the factory bolt, secure the Air Control Solenoid Valve to the bracket on the upper intake pipe as shown.

**NOTE: If vacuum lines are installed incorrectly, the vehicle will show a check engine light when started. Disconnect the battery and reinstall the vacuum lines properly.**

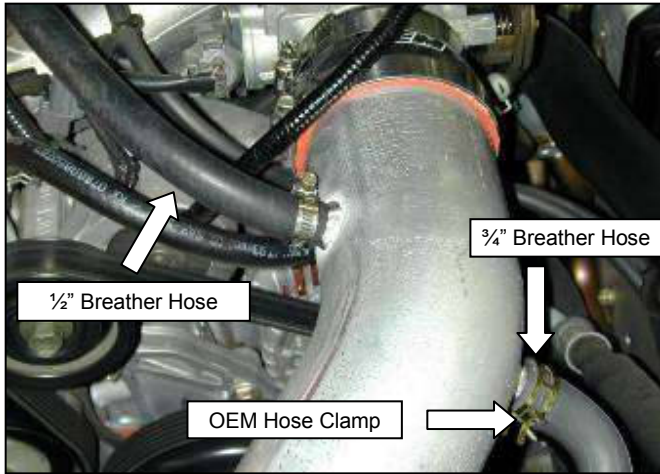

f. Install the upper intake pipe by inserting the end with the 1/2" nipple into the 3.25" side of the coupler on the throttle body. Attach the 1/2" breather hose and the 3/4" factory breather hose as shown. Use the factory hose clamp on the 3/4" hose and the supplied hose clamp on the 1/2" hose.



g. Install the supplied rubber mount into the passenger side radiator support frame rail as shown. When tightening the nut, tighten until the thin outer wall of the support starts to deflect (See step 3h for a closer view).



h. Install the supplied rubber mount into the passenger side radiator support frame rail as shown. When tightening the nut, tighten until the thin outer wall of the support starts to deflect.

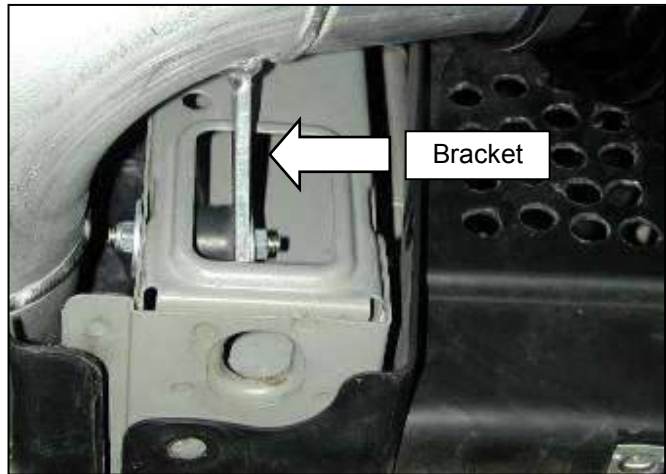

i. Install the lower intake pipe behind the radiator with the bracket sliding onto the rubber mount. Use the washer and screw on the nylok nut but do not tighten at this time.



j. Using the 3.25" silicone hose and two #48 hose clamps supplied, attach the upper and lower intake pipes together.

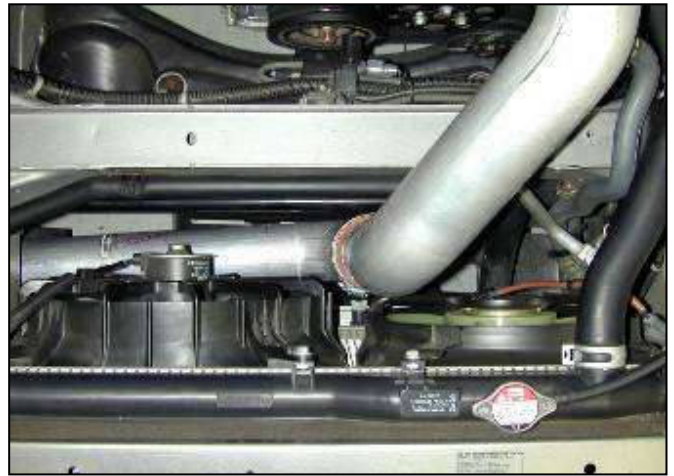

k. Ensure there is sufficient clearance between the lower intake pipe and radiator fan guard, the A/C line, and the sway bar.



l. Trim inner fender liner and under tray as shown for proper fit.

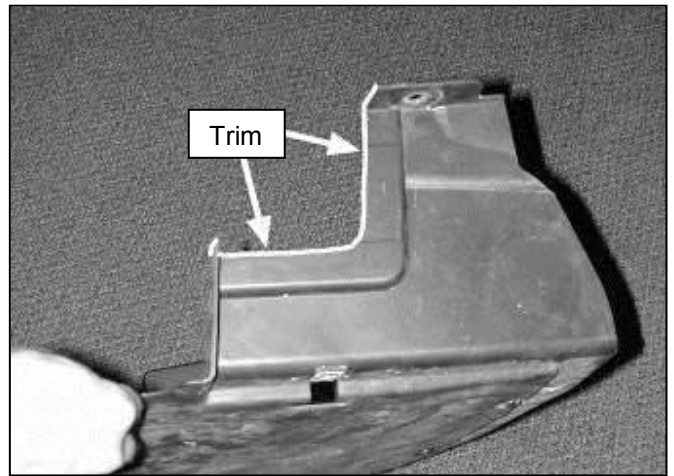

m. Trim the passenger side under tray as shown to provide cooler air to the air filter element. Install the under tray, trimming or notching them for tube clearance where required.

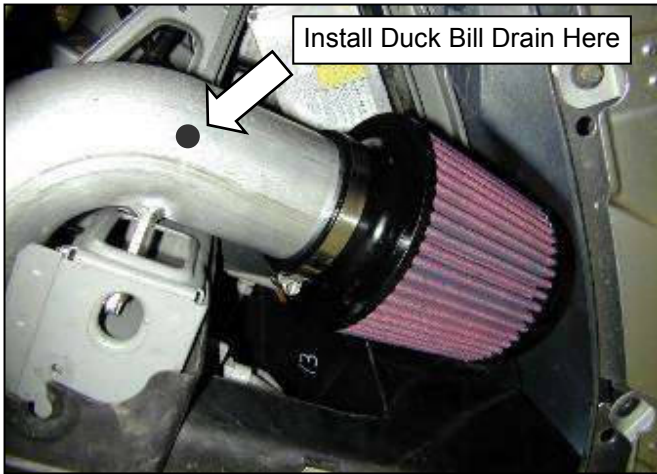

n. Install the AEM® air filter onto the end of the intake pipe. Push the air filter over the inlet pipe until the stop in the air filter is reached. Then install one hose clamp to secure the air filter onto the inlet pipe. Once fitment is checked, tighten the hose clamp.



o. Ensure the air filter is not touching any part of the vehicle. Position the inlet pipe for best fitment. Be sure that the intake pipe or any other component is not in contact with any part of the vehicle. Tighten the hose clamps at the throttle body and silicone coupling. Tighten the nut on the mounting bracket. Check for proper hood clearance. Re-adjust pipe if necessary.



Factory air box system installed



AEM® intake system installed

#### 4. Reassemble Vehicle

a. **Fender liner and splashguard:** Install the fender liner, lower splash guard and any hardware that was removed in steps 2d.

**NOTE: Failure to install the fender liner will result in diminished performance and increase the potential for engine damage due to water ingestion in rainy conditions.**

b. **Wheel:** Install the passenger side wheel using the factory torque specification (see owner's manual).

c. Position the inlet pipes for the best fitment. Be sure that the pipes or any other components do not contact any part of the vehicle. Tighten the rubber mount, all bolts, and hose clamps.

d. Check for proper hood clearance. Re-adjust pipes if necessary and re-tighten them.

e. Inspect the engine bay for any loose tools and check that all fasteners that were moved or removed are properly tightened.

f. Reconnect negative battery terminals and start engine. Let the vehicle idle for 3 minutes. Perform a final inspection before driving the vehicle.

## 5. CARB Sticker Placement

- a. The C.A.R.B. exemption sticker, (attached), must be visible under the hood so that an emissions inspector can see it when the vehicle is required to be tested for emissions. California requires testing every two years, other states may vary.

## 6. Service and Maintenance

- a. It is recommended that you service your AEM<sup>®</sup> Dryflow™ filter every 20,000 miles for optimum performance. Use AEM Dryflow cleaning kit part # 21-110.
- b. Use aluminum polish to clean your polished AEM<sup>®</sup> intake tube.
- c. Use window cleaner to clean your powder coated AEM<sup>®</sup> intake tube. **(NOTE: DO NOT USE aluminum polish on powder coated AEM intake tubes).**

For technical inquiries  
e-mail us at  
sales@aemintakes.com  
or  
call us at  
800.992.3000

### AEM Air Intake System Warranty Policy

AEM<sup>®</sup> warrants that its intake systems will last for the life of your vehicle. AEM will not honor this warranty due to mechanical damage (i.e. improper installation or fitment), damage from misuse, accidents or flying debris. AEM will not warrant its powder coating if the finish has been cleaned with a hydrocarbon-based solvent. The powder coating should only be cleaned with a mild soap and water solution. Proof of purchase of both the vehicle and AEM intake system is required for redemption of a warranty claim.

This warranty is limited to the repair or replacement of the AEM part. In no event shall this warranty exceed the original purchase price of the AEM part nor shall AEM be responsible for special, incidental or consequential damages or cost incurred due to the failure of this product. Warranty claims to AEM must be transportation prepaid and accompanied with dated proof of purchase. This warranty applies only to the original purchaser of product and is nontransferable. Improper use or installation, use for racing, accident, abuse, unauthorized repairs or alterations voids this warranty. AEM disclaims any liability for consequential damages due to breach of any written or implied warranty on all products manufactured by AEM. Warranty returns will only be accepted by AEM when accompanied by a valid Return Merchandise Authorization (RMA) number. Credit for defective products will be issued pending inspection. Product must be received by AEM within 30 days of the date RMA is issued.

If you have a warranty issue, please call (800) 992-3000 and our customer service department will assist you. A proof of purchase is required for all AEM warranty claims.

**Intake systems for vehicles listed are 50  
state legal. See AEMIntakes.com for CARB  
status on each part for a specific vehicle.**