



Equipped with AEM® Dryflow™ Filter
No Oil Required!

INSTALLATION INSTRUCTIONS

PART NUMBER:

21-685C

(Gun Metal Grey Finish)

21-685P

(Vacuum Metalized Chrome - VMC)

2006-2011 HONDA Civic SI L4-2.0L C.A.R.B. E.O. # D-670-21

PARTS LIST

Description	Qty.	Part Number
A Air Filter Assy. 3.00 X 5" Dry Ele.	1	21-203DK
B Upper Pipe	1	2-419C/AP
C Lower Pipe	1	2-1405C/AP
D Elbow, 2.75/3.00 X 90 Off Set	1	5-281
E Hose, Adapter 3.00 Flow St/ Ven.	1	5-304
F Hose, Radiator	1	5-585
G Hose; 5/8"ID X 18"L	1	5-7018
H Hose; 5/16ID X 12"L	1	5-2012
I Hose; 1/2"ID X 11"L	1	5-5011
J Mount, Rubber 5/8" X 6mm	1	1228598
K Helical Bundling Wrap; 1/2" X 4"L	1	8-8004
L Bracket	1	32-3058
M Bolt, Hex/Flange M6-1.0 X 12	1	1-2110
N Washer, 6mm Soft Mount	1	08160
O Nut, M6 Hex Serrated	1	444.460.04
P 1/2" Bnd. Hose Clamp,2.90"-3.75"	1	9452
Q 1/2" Bnd. Hose Clamp,2.31-3.25"	1	9444
R 1/2" Bnd. Hose Clamp,2.56"-3.50"	3	9448
S Hose Clamp, 1 1/16" Narrow	4	08411
T Hose Clamp, 3/4"	2	4093-5

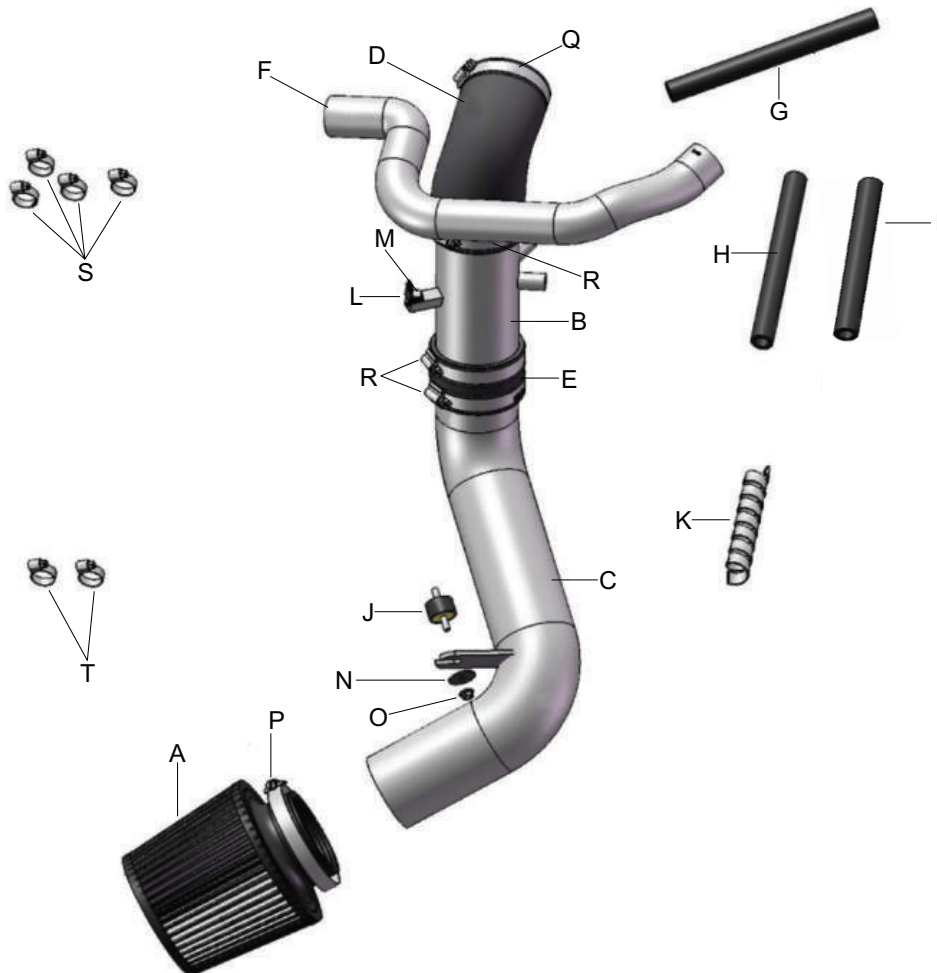

Read and understand these instructions **BEFORE** attempting to install this product. Failure to follow installation instructions and not using the provided hardware may damage the intake tube, throttle body and engine.

The AEM® intake system is a performance product that can be used safely during mild weather conditions. During harsh and inclement weather conditions, you must return your vehicle to stock OEM air box and intake tract configuration. Failure to follow these instructions will void your warranty.

1. Preparing Vehicle

- a. Make sure vehicle is parked on level surface.
- b. Set parking brake.
- c. If engine has run in the past two hours, let it cool down.
- d. Do not discard stock components after removal of the factory system.

2. Removal of stock system



a. Stock air box system installed.

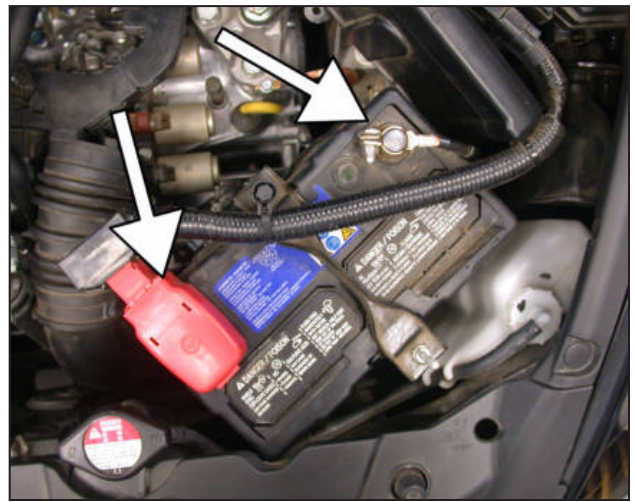

b. Disconnect the negative and positive battery terminals. Remove the battery tie down and battery according to the owner's manual.



c. Disconnect the mass airflow (MAF) sensor from the vehicle.

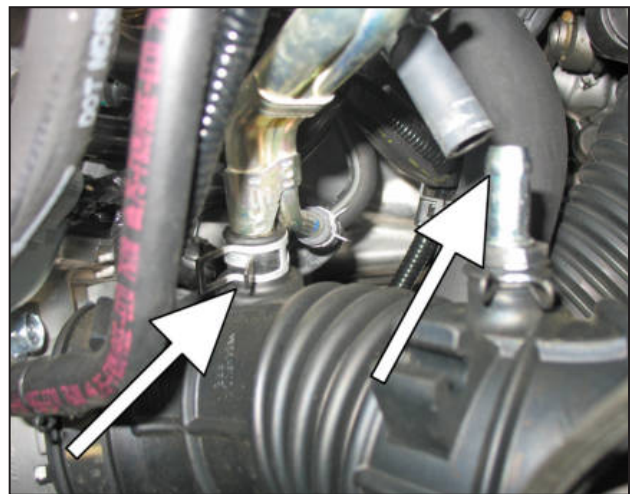

d. Disconnect the two breather hoses connected to the rubber intake tube. One is a hard line and the other is rubber.

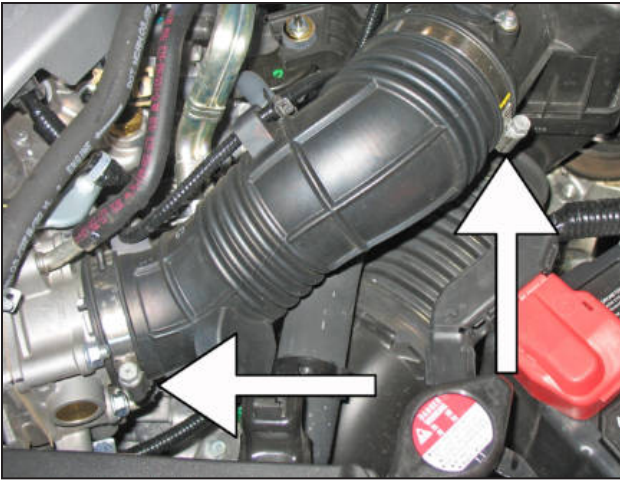

e. Loosen the two hose clamps securing the rubber inlet tube to the stock air box and the throttle body. Remove the rubber inlet tube from the vehicle.



f. Remove the MAF sensor from the air box. Unclip the upper air box from the lower air box.



g. Remove the upper air box and air filter from the lower air box. Remove the two bolts and one nut securing the lower air box to the vehicle.

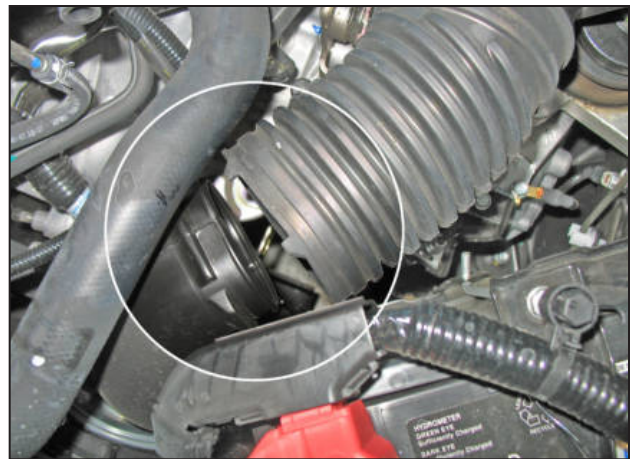

h. Disconnect the lower rubber inlet tube connecting the lower air box to the plastic inlet tube routed through the bottom of the vehicle.



i. Stock air box system removed from the vehicle.

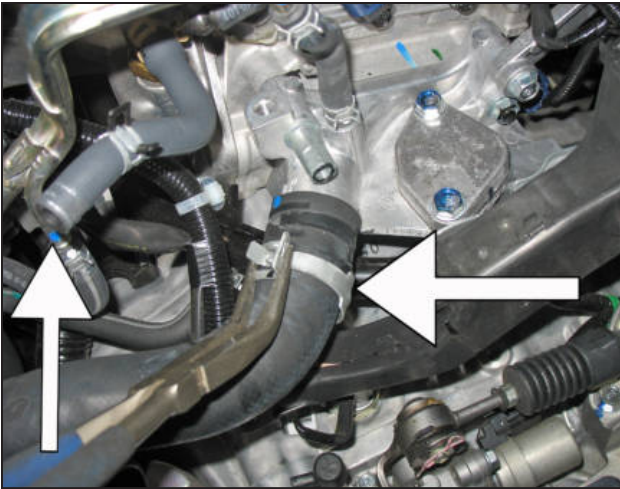

j. **NOTE: Ensure the engine is completely cool before removing the coolant hose, or hot coolant will escape from the cooling system and cause injury or damage. To do this, the radiator coolant must first be drained. Follow the procedure described in your vehicle's factory service manual to drain the coolant. Be sure to capture the coolant in a clean container so it can be recycled back into the system in a later step.**
 Using pliers remove the clamp securing the upper radiator hose to the engine. Also, remove the smaller breather hose (seen in the upper left hand side of the image).

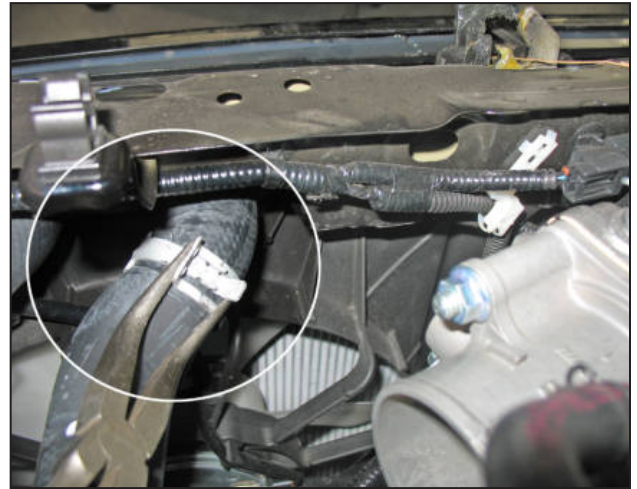

k. Using pliers remove the clamp securing the upper radiator hose to radiator. Remove the upper radiator hose from the vehicle.

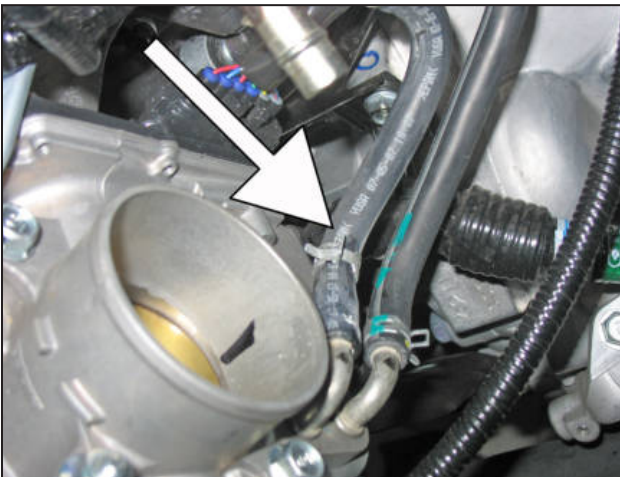

l. Disconnect the coolant line connected to the throttle body.

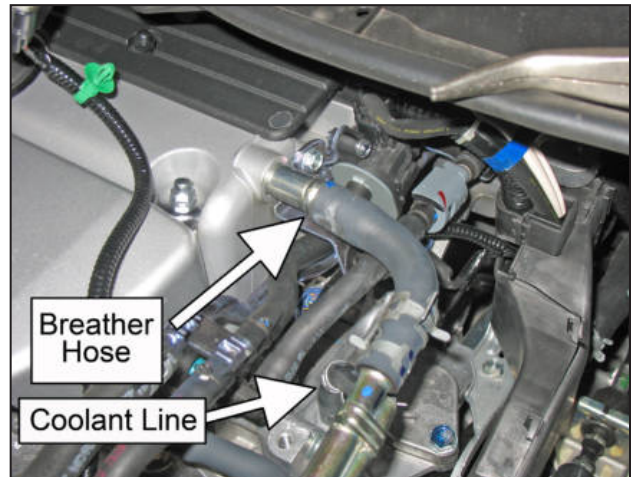

m. Disconnect the breather hose from the valve cover and disconnect the small coolant line connecting the engine to the hard lines.

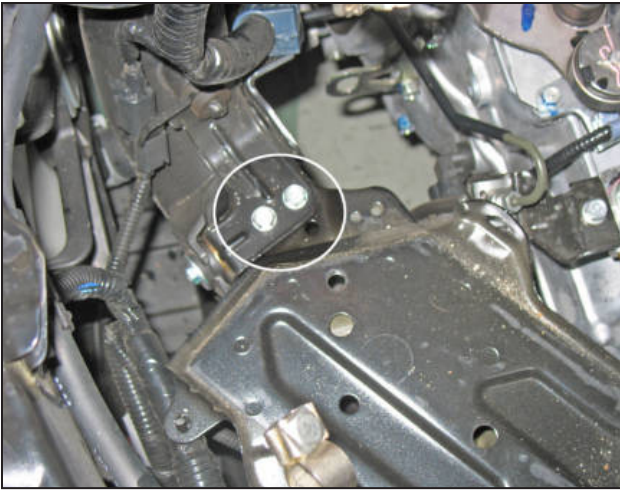

n. Remove the lower inlet tube and the bracket securing the positive battery cable. The bracket securing the positive battery cable has two bolts that will need to be removed.



o. Raise the front of the vehicle with a jack. Refer to your owner's manual for proper jack and jack stand placement to properly support vehicle. Support your vehicle using properly rated jack stands before wheel removal or while working under the vehicle. **NEVER WORK UNDER A VEHICLE WITHOUT USING JACK STANDS.** Remove the driver side wheel.



p. Remove the fender liner on the driver side wheel.

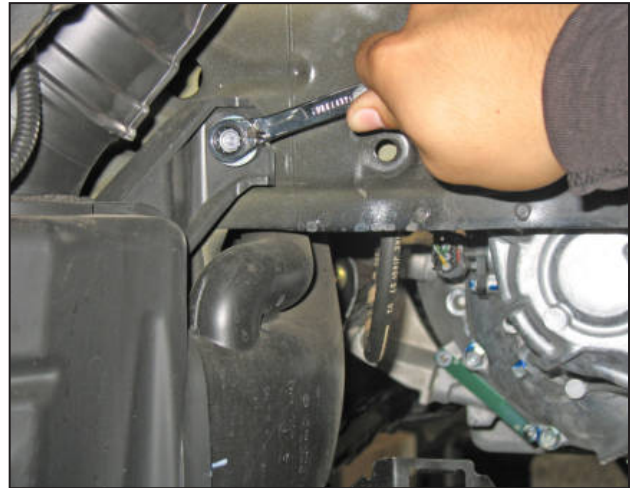

q. Remove the bolt securing the resonator to the inner fender well.

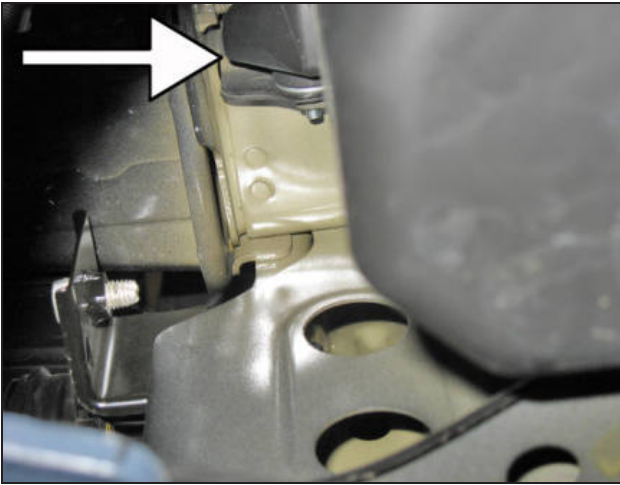

r. Remove the second bolt securing the lower resonator in place; it is located near the front of the vehicle.



s. Stock air box system removed from the vehicle.

3. Installation of AEM® intake system.

a. When installing the intake system, do not completely tighten the hose clamps or mounting hardware until instructed to do so.



b. Carefully install the MAF sensor into the upper intake pipe using the two stock bolts.

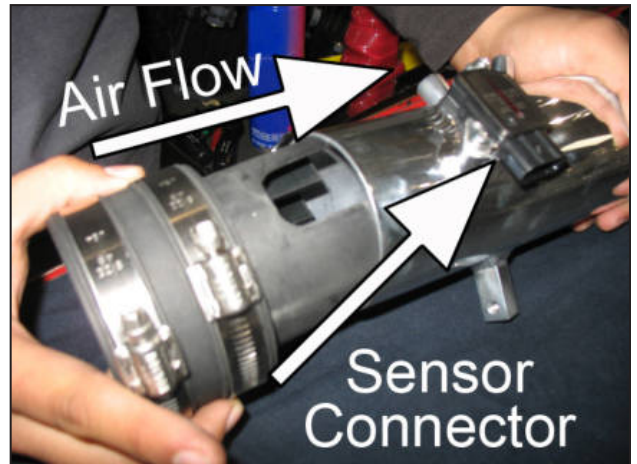

c. Align the airflow straightener/coupler with the MAF sensor and insert into the upper intake pipe. Ensure the airflow straightener/coupler is properly oriented as shown. Slide two #48 hose clamps onto the coupler as shown, but do not completely tighten.

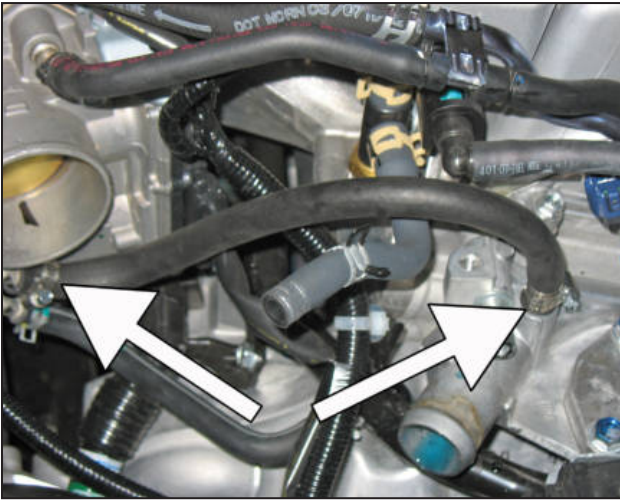

d. Install the supplied 5/16" hose to the throttle body inlet and the engine inlet as shown. Secure each end of the hose with the provided hose clamps.



e. Install the supplied radiator hose using the stock hose clamps.



f. Route the radiator hose as shown. Trim the battery tray for clearance if necessary.

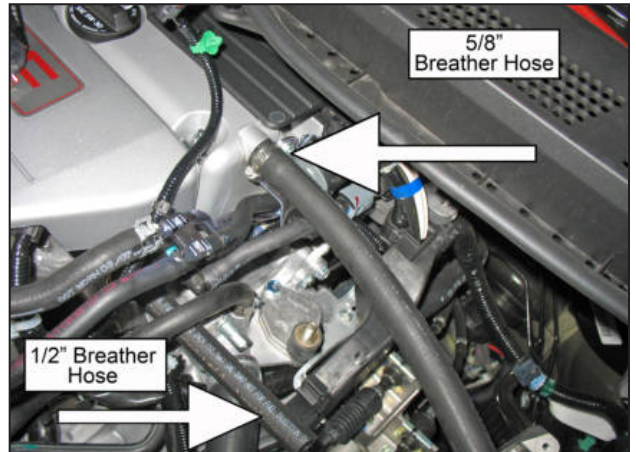

g. Install the two supplied breather hoses, one to the valve cover and the other to the small plastic valve located on the engine. Secure each hose with the supplied hose clamps.



h. Install the elbow coupler onto the throttle body, ensuring it does not contact any of the surrounding parts. Loosely secure it with the supplied #9444 hose clamp.



i. Install the intake assembly assembled in step 3c into the elbow. Connect the MAF sensor to the MAF sensor harness connector. Ensure the intake pipe is completely seated into the elbow and is properly positioned so it does not obstruct the shift linkage. Put the vehicle in third gear to ensure that the intake pipe will clear the shift linkage. Connect the two breather hoses installed in step 3g to the upper intake pipe and secure with the supplied hose clamps.
NOTE: This installation step is critical, please take your time and make sure that the upper intake pipe is NOT interfering with the vehicle's shift linkage.



j. Install bracket #32-3058 onto the upper intake pipe's bracket with the supplied bolt #1-2110. Attach the blue harness to the metal clip.

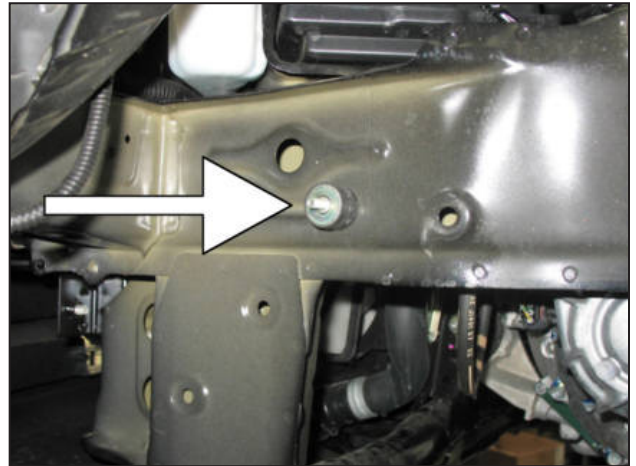

k. Screw the rubber mount into the threaded hole of vehicle's frame.



l. Route the lower intake pipe into the engine bay and attach the upper end to the upper intakes pipe's coupler.



m. Install the supplied helical wrap onto the clutch line where the lower intake pipe passes.

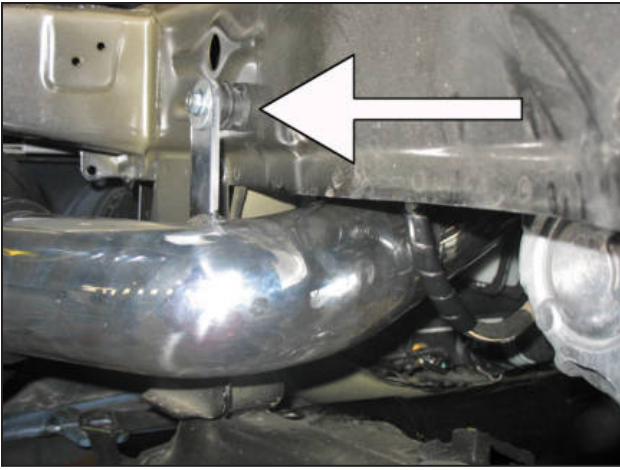

n. Loosely secure the lower intake pipe's bracket to the rubber mount installed in step 3k. Secure the bracket with the supplied washer and serrated nut.



o. Install the air filter onto the lower end of the lower intake pipe. Once proper fitment is achieved secure the air filter to the intake pipe with a #9452 hose clamp.



p. Install the fender liner and any hardware that was removed in step 2p. Trim the fender liner to allow clearance for the lower intake pipe.
NOTE: Failure to install the fender liner will result in diminished performance and increase the potential for engine damage due to water ingestion in rainy conditions.



Factory air box system installed

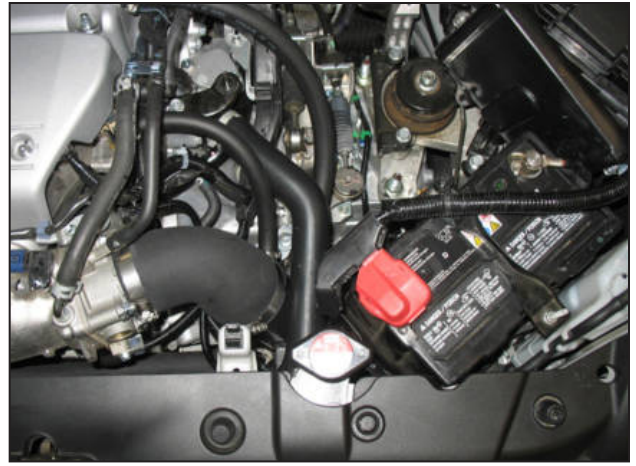

AEM® intake system installed

4. Reassemble Vehicle

- a. **Be sure to replenish the coolant that was drained during step 2j. Be sure to purge the coolant system before driving the vehicle. For any additional details regarding this procedure refer to the factory service manual.**
- b. Position the inlet pipes for the best fitment. Be sure that the pipes or any other components do not contact any part of the vehicle. Tighten the rubber mount, all bolts, and hose clamps.
- c. With the engine turned off, have a friend run the shift lever through the 6 gears, and ensure that the counter weight for the shift rod does not contact the intake pipe. If the shifter rod makes contact with the pipe, **DO NOT** drive the vehicle until this has been corrected by re-adjusting the pipe so it does not make contact.
- d. **Wheel:** Install the driver side wheel using the factory torque specification (see owner's manual).
- e. Check for proper hood clearance. Re-adjust pipes if necessary and re-tighten them.
- f. Install the battery and battery tie down according to the owners manual. Reconnect the positive battery terminal.
- g. Inspect the engine bay for any loose tools and check that all fasteners that were moved or removed are properly tightened.
- h. Reconnect negative battery terminal and start engine. Let the vehicle idle for 3 minutes. Perform a final inspection before driving the vehicle.

5. CARB Sticker Placement

- a. The C.A.R.B. exemption sticker, (attached), must be visible under the hood so that an emissions inspector can see it when the vehicle is required to be tested for emissions. California requires testing every two years, other states may vary.

6. Service and Maintenance

- a. AEM Induction Systems requires cleaning the intake system's air filter element every 100,000 miles. When used in dusty or off-road environments, our filters will require cleaning more often. We recommend that you visually inspect your filter once every 25,000 miles to determine if the screen is still visible. When the screen is no longer visible some place on the filter element, it is time to clean it. To clean, purchase our Synthetic air filter cleaner, part number 99-0624 and follow the easy instructions.
- b. Use window cleaner to clean your powder coated AEM® intake tube.
NOTE: DO NOT USE aluminum polish on powder coated AEM® intake tubes.

For technical inquiries
e-mail us at
sales@aemintakes.com
or
call us at
800.992.3000

AEM Air Intake System Warranty Policy

AEM® warrants that its intake systems will last for the life of your vehicle. AEM will not honor this warranty due to mechanical damage (i.e. improper installation or fitment), damage from misuse, accidents or flying debris. AEM will not warrant its powder coating if the finish has been cleaned with a hydrocarbon-based solvent. The powder coating should only be cleaned with a mild soap and water solution. Proof of purchase of both the vehicle and AEM intake system is required for redemption of a warranty claim.

This warranty is limited to the repair or replacement of the AEM part. In no event shall this warranty exceed the original purchase price of the AEM part nor shall AEM be responsible for special, incidental or consequential damages or cost incurred due to the failure of this product. Warranty claims to AEM must be transportation prepaid and accompanied with dated proof of purchase. This warranty applies only to the original purchaser of product and is nontransferable. Improper use or installation, use for racing, accident, abuse, unauthorized repairs or alterations voids this warranty. AEM disclaims any liability for consequential damages due to breach of any written or implied warranty on all products manufactured by AEM. Warranty returns will only be accepted by AEM when accompanied by a valid Return Merchandise Authorization (RMA) number. Credit for defective products will be issued pending inspection. Product must be received by AEM within 30 days of the date RMA is issued.

If you have a warranty issue, please call (800) 992-3000 and our customer service department will assist you. A proof of purchase is required for all AEM warranty claims.