



Equipped with AEM® Dryflow™ Filter

No Oil Required!

INSTALLATION INSTRUCTIONS

PART NUMBER:

21-731P (Vacuum Metalized Chrome-VMC)

2014

Ford

Fiesta

1.6L

C.A.R.B. E.O. D-670-19

Intake systems for vehicles listed are 50 state legal. See AEMIntakes.com for CARB status on each part for a specific vehicle.

PARTS LIST

ITEM NO.	PART NUMBER	DESCRIPTION	QTY
1	20-8522	HEAT SHIELD; FORD FIESTA 1.6L	1
2	2-1421	INTAKE TUBE; FORD FIESTA 1.6L	1
3	5-255	HOSE, ADAPTER 2.25/2.5" X3"	1
4	444.460.04	NUT, M6 HEX SERRATED	2
5	9436	1/2' BNDHOSE CLAMP,1.81"-2.75"	1
6	9440	1/2' BNDHOSE CLAMP,2.15-3.00"	1
7	2-670	STAND, ALUMINUM	2
8	1228596	MOUNT, RUBBER M6 X 3/4" TALL	1
9	1-2075	BOLT, HEX/FLANGE M6-1 X 40	2
10	21-2011D	AIR FILTER; 2-1/2" FLG, 5-1/2" B, 4-3/4" T, 5"H	1
11	9444	1/2" BNDHOSE CLAMP,2.31-3.25"	1
12	08160	WASHER; 1"D X 1/4 HOLE FENDER	3
13	102486	EDGE TRIM; 3/4"BULB; TOP LOC, 44"L	1
14	5-1028	HOSE; 3/8"ID X 28"L	1

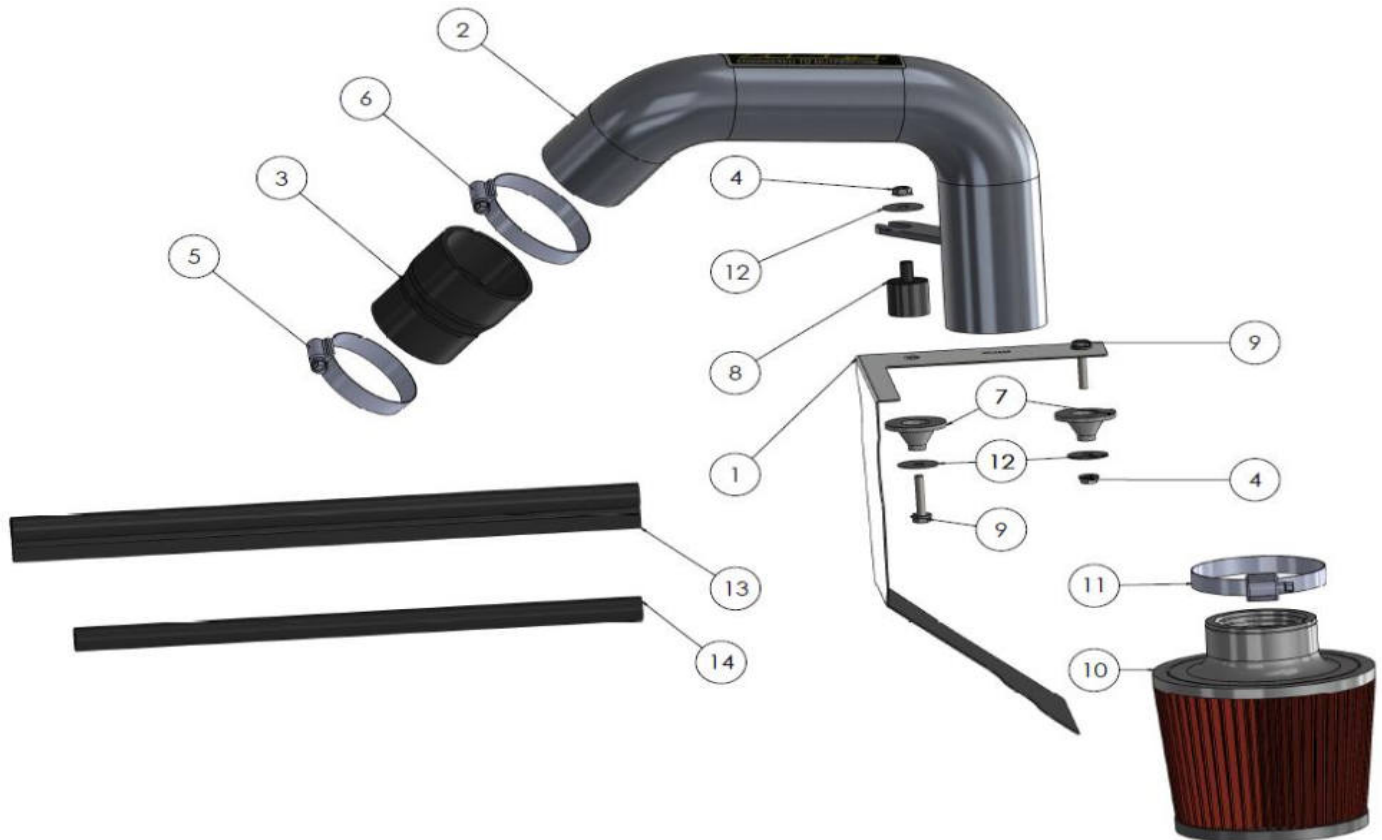

Read and understand these instructions **BEFORE** attempting to install this product. Failure to follow installation instructions and not using the provided hardware may damage the intake tube, throttle body and engine.

The AEM[®] intake system is a performance product that can be used safely during mild weather conditions. During harsh and inclement weather conditions, you must return your vehicle to stock OEM airbox and intake tract configuration. Failure to follow these instructions will void your warranty.

1. Preparing Vehicle

- a. Make sure vehicle is parked on a level surface.
- b. Set parking brake.
- c. If engine has run in the past two hours, let it cool down.
- d. Disconnect negative battery terminal.
- e. Do not discard stock components after removal of the factory system.

2. Removal of stock system

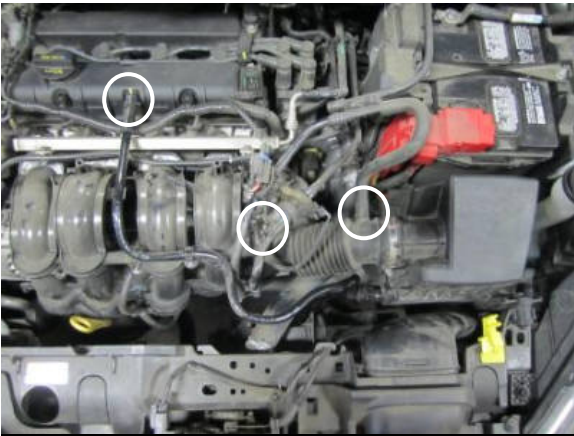

Disconnect the vent hoses from the valve cover and intake tube. Loosen the throttle body hose clamp.



Slide the intake tube off of the throttle body and disengage the air scoop from the radiator shroud.

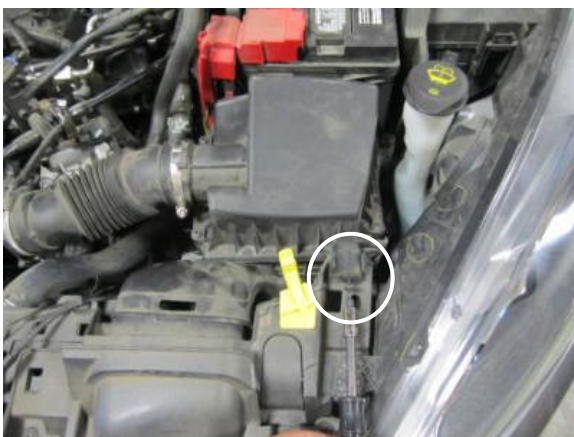

Using a T-15 Torque socket, remove the bolt and mount assembly. This will not be re-used, however do not discard.



Remove the complete stock intake by pulling up and out of the vehicle. **DO NOT DISCARD YOUR STOCK INTAKE.**

3. Installation of AEM Intake System

- a. When installing the intake system, do not completely tighten the hose clamps or mounting hardware until instructed to do so.



Install both aluminum stands into the stock bushings. Install the coupler and two hose clamps onto the throttle body.



Install the provided edge trim onto the heat shield as shown. Trimming may be necessary.



Install the heat shield and rubber mount with the provided hardware and tighten. Slide the coupler into the throttle body with the provided hose clamps.



Attach the air filter and hose clamp to the intake tube. Tighten the hose clamp at this time.



Install the intake tube with the filter into the throttle body coupler aligning the bracket with the rubber mount.

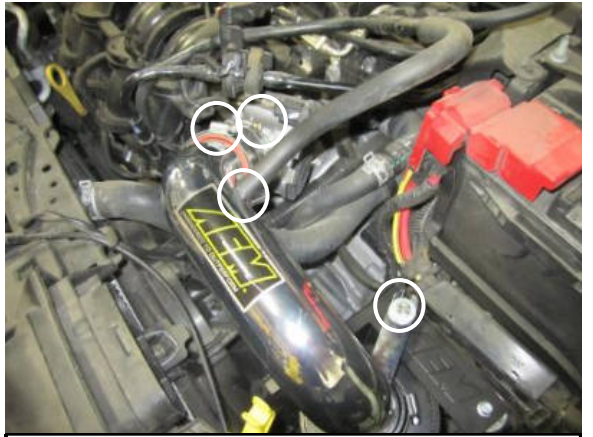

Use the provided hardware to secure the bracket to the mount. Tighten the two throttle body hose clamps at this time. Also, attach the stock vent hose to the top fitting on the AEM tube.

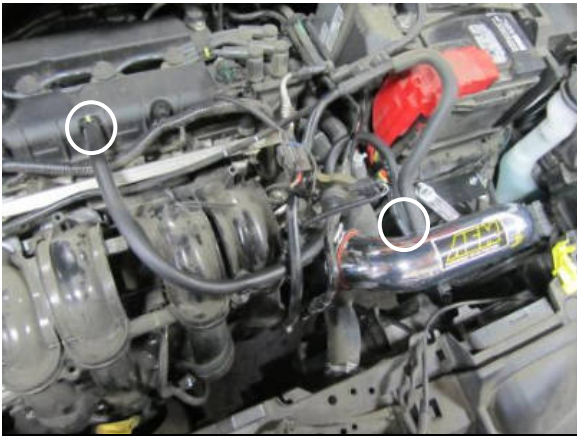

Attach the provided hose to the valve cover and to the lower fitting on the AEM tube.



Stock Intake Installed



AEM Intake Installed

4. Reassemble Vehicle

- a. Position the inlet pipes for the best fitment. Be sure that the pipes or any other components do not contact any part of the vehicle. Tighten any rubber mounts (if applicable), all bolts, and hose clamps.
- b. Check for proper hood clearance. Re-adjust pipes if necessary and re-tighten them.
- c. Inspect the engine bay for any loose tools and check that all fasteners that were moved or removed are properly tightened.
- d. Reconnect the negative battery terminal and start the engine. Let the vehicle idle for 3 minutes. Perform final inspection before driving the vehicle.

5. CARB Sticker Placement

- a. The C.A.R.B. exemption sticker, (attached), must be visible under the hood so than an emissions inspector can see it when the vehicle is required to be tested for emissions. California requires testing every two years, other states may vary.

6. Service and Maintenance

- a. AEM Induction Systems requires cleaning the intake system's air filter element every 100,000 miles. When used in dusty or off-road environments, our filters will require cleaning more often. We recommend that you visually inspect your filter once every 25,000 miles to determine if the screen is still visible. When the screen is no longer visible some place on the filter element, it is time to clean it. To clean, purchase our Synthetic air filter cleaner, part number 1-1000 and follow the easy instructions.
- b. Use window cleaner to clean your powder coated AEM[®] intake tube. **NOTE: DO NOT USE aluminum polish on powder coated AEM[®] intake tubes.**

For Technical inquiries
E-mail us at
sales@aemintakes.com
Or
Call us at
800.992.3000

AEM[®] Air Intake System Warranty Policy

AEM[®] warrants that its intake systems will last the life of your vehicle. AEM[®] will not honor this warranty due to mechanical damage (i.e. improper installation or fitment), damage from misuse, accidents or flying debris. AEM[®] will not warrant its powder coating if the finish has been cleaned with a hydrocarbon-based solvent. The powder coating should only be cleaned with a mild soap and water solution. Proof of purchase of both the vehicle and AEM[®] intake system is required for redemption of a warranty claim.

This warranty is limited to the repair or replacement of the AEM[®] part. In no event shall this warranty exceed the original purchase price of the AEM[®] part nor shall AEM[®] be responsible for special, incidental or consequential damages or cost incurred due to the failure of this product. Warranty claims to AEM[®] must be transportation prepaid and accompanied with dated proof of purchase. This warranty applies only to the original purchaser of product and is nontransferable. Improper use or installation, use for racing, accident, abuse, unauthorized repairs or alterations voids this warranty. AEM disclaims any liability for consequential damages due to breach of any written or implied warranty on all products manufactured by AEM[®]. Warranty returns will only be accepted by AEM[®] when accompanied by a valid Return Merchandise Authorization (RMA) number. Credit for the defective products will be issued pending inspection. Product must be received by AEM[®] within 30 days of the date RMA is issued.

If you have a warranty issue, please call (800) 992-3000 and our customer service department will assist you. A proof of purchase is required for all AEM[®] warranty claims.

Intake systems for vehicles listed are 50 state legal. See AEMIntakes.com for CARB status on each part for a specific vehicle.