



Equipped with AEM® Dryflow™ Filter
No Oil Required!

INSTALLATION INSTRUCTIONS

PART NUMBER

21-783C (Gun Metal Gray Finish)

2016	HYUNDAI	TUCSON	1.6L TURBO	C.A.R.B. E.O# D-670-24
2017	HYUNDAI	TUCSON	1.6L TURBO	

ITEM NO.	PART NUMBER	DESCRIPTION	QTY.
1	9440	HOSE CLAMP, 2.15-3.00"	1
2	5-574	HOSE; HUMP 2.50/3.00 X 3.00"	1
3	9448	1/2" BNDHOSE CLAMP, 2.56"-3.50"	2
4	2-1563C	INTAKE TUBE; 3.0"OD X 13"L, 21-783	1
5	5-1046	HOSE, ADAPTER 3.00/3.50X2.5	1
6	9456	1/2" BNDHOSE CLAMP, 3.15"-4.00"	1
7	07730	BOLT; M6 X 1.00 X 16MM , BUTTON	2
8	1-3025	WASHER, M6 SPLIT LOCK ZINC	2
9	08275	WASHER; 1/4"ID X 5/8"OD - SAE	4
10	20-8546-1	HEAT SHIELD; HYUNDAI 2015, TB/PC	1
11	8-125	CONNECTOR, PLASTIC 3/8" STRAIGHT	1
12	5-1022	HOSE; 3/8"ID X 22"L	1
13	102487	EDGE TRIM; 3/4" BULB, TOP LOC., 46"L	1
14	444.460.04	NUT; M6 HEX SERRATED	2
15	1228599	MOUNT, RUBBER 1" X 6MM	2
16	8-186-1	MOUNT, PLASTIC AIRBOX, NYLON	1
17	1-2108	BOLT; HEX/FLANGE M8-1.25 X 12	1
18	08272	WASHER; 8MM, FLAT, SS	1
19	06532	STANDOFF; 6.0 FORD AIRBOX	1
20	21512-1	ADAPTER; UNIVERSAL, 6" FILTER 3.5"	1
21	94104	1/2" BNDHOSE CLAMP, 4.125-7.00"	1
22	21-209DK	AIR FILTER; 6" X 5" X 4.75" T DRYFLOW	1
23	8-101	VACUUM CAP, 3/8"	2

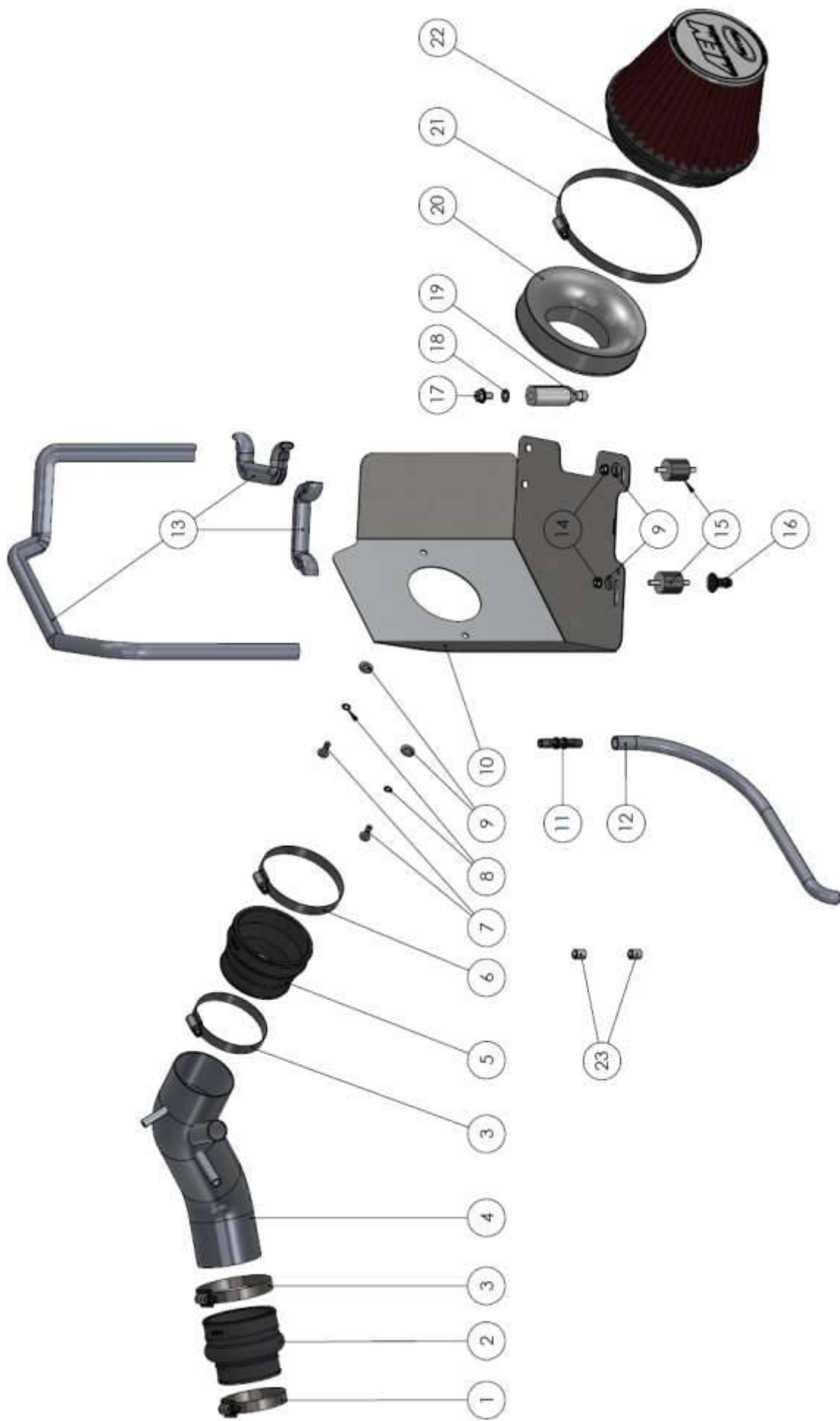

Read and understand these instructions **BEFORE** attempting to install this product. Failure to follow installation instructions and not using the provided hardware may damage the intake tube, throttle body and engine. If you need any assistance please call 1-800-858-3333 to speak with a representative in our Customer Service Center before returning the product.

1. Preparing Vehicle

- a. Make sure vehicle is parked on level surface.
- b. Set the parking brake.
- c. If engine has run in the past two hours, let it cool down.
- d. Disconnect negative battery terminal.
- e. Do not discard stock components after removal of the factory system.
- f. Open the air intake kit package and make sure all parts are included.

Tools Needed:

Screw driver
10 & 12MM Socket
Socket Driver
Side Cutters
Pliers
Knife
Warm Soap & Water

2. Removal of stock system



a. Remove the two clips securing the stock scoop to the vehicle.



b. Remove the battery hold down bolt and bracket. Then slide the battery as far forward as possible. The bolt and bracket will be reinstalled in step 3q.



c. Squeeze the spring clamps and work them back off of the vent lines and disconnect the vent lines from the stock intake tube.



d. Remove the bolt behind the battery that secures the stock air box to the engine compartment.



e. Loosen the hose clamp at the stock air box. Then remove the stock air box from the vehicle.

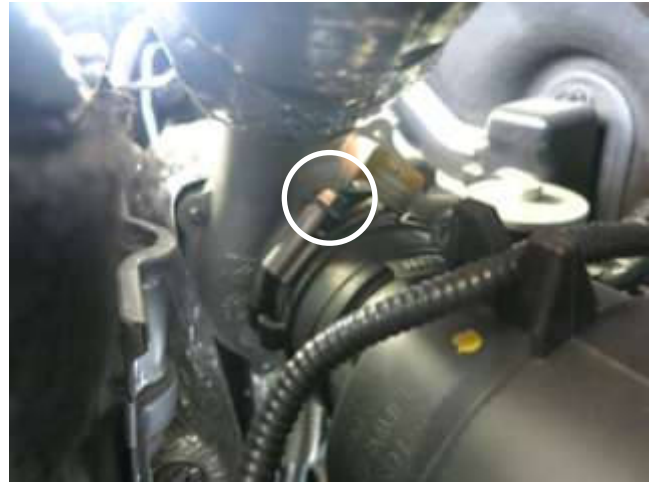

f. Loosen the hose clamp at the turbo compressor.



g. Remove the wiring harness loom from the clip in the stock intake tube and remove the stock intake tube from the vehicle.



h. Your vehicle should now look like this. NOTE: Do not discard any of your stock equipment.



i. Squeeze and work the spring clamp back on the EVAP vent line and remove it from the hard line. Note: You can see the turbo compressor in the back of the picture for reference to locate the vent line.



j. Follow the hard line from the previous step to the "T" fitting. Remove the short vent line and spring clamps from the hard line to the "T" fitting. The spring clamps will be reused in step 3g & 3i.

3. Installation of AEM® intake system.

a. When installing the intake system, do not completely tighten the hose clamps or mounting hardware until instructed to do so.



a. Install the provided rubber bushings and plastic mount into the vehicle. Note: You will screw one bushing into the plastic mount as shown in corner of picture.



c. Install the filter adaptor with the provided hardware onto the heat shield as shown.

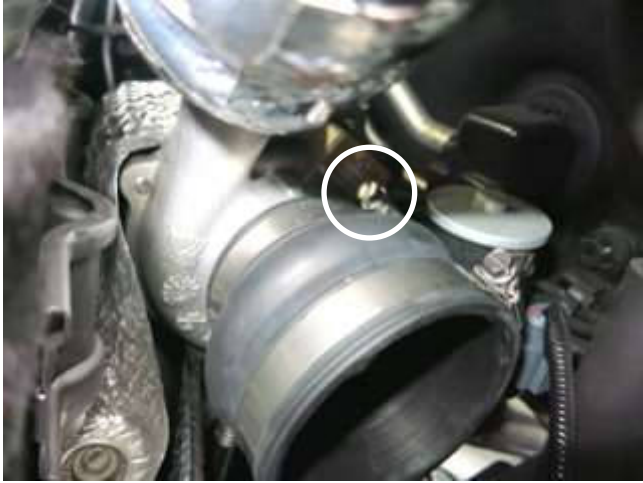

b. Install the provided coupler and hose clamps onto the turbo compressor inlet. Tighten the hose clamp circled at this time.



d. Install the stand-off and provided hardware onto the heat shield. You will install it on the inside hole.



e. Install the provided coupler and hose clamps onto the filter adaptor. Tighten the hose clamp circled at this time.



g. Using the providing hose, install the union into one end and secure with a spring clamp removed in step 2j.



i. Route the previous hose above the “hard line” and too the “T” fitting. Connect the other end of the hose to the “T” fitting and secure with the spring clamp from step 2j. Then, with the two provided vacuum caps, cap the ends of the hard line.



f. Install the provided edge trim onto the completed heat shield. Note: Some trimming may be necessary.



h. Connect the previously assembled hose to the EVAP vent line that was disconnected in step 2i, and secure with the spring clamp.



j. Install the AEM intake tube into the coupler at the turbo compressor. Note: Soapy water will help installation and adjustment.



k. Install the completed heat shield into the vehicle aligning the slots in the shield to the previously installed studs. Install the washers/nuts and tighten.



l. Push the heat shield down to secure the stand-off into the grommet in the vehicle while aligning the intake tube with the coupler.



m. After proper tube alignment is achieved, tighten the hose clamp around the tube at the turbo.



n. Tighten the hose clamp on the coupler at the heat shield.



o. Install the vent hoses and spring clamps that were removed in step 2c.

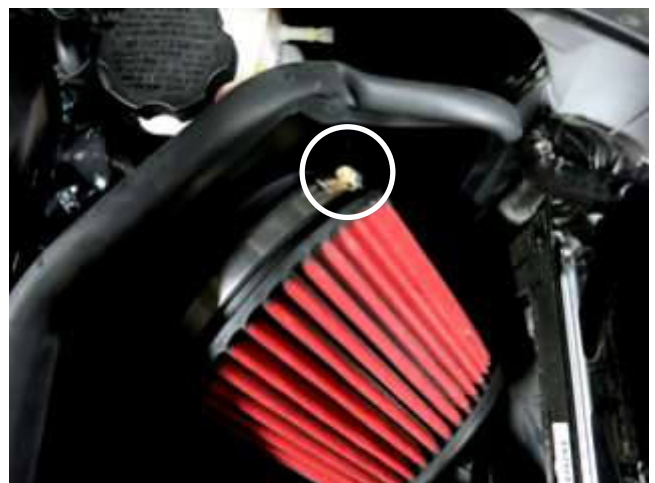

p. Install the AEM filter onto the filter adaptor and tighten the hose clamp.



q. Re-center the battery in the tray and install the battery hold down with the bolt that was removed in step 2b.

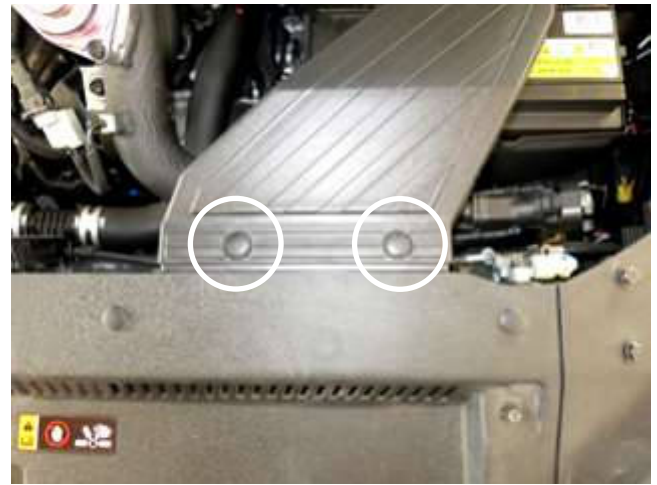

r. Install the stock scoop back into the vehicle with the clips that were removed in step 2a.



STOCK INTAKE INSTALLED



AEM INTAKE INSTALLED

4. Reassemble Vehicle

- a. Position the inlet pipes for the best fitment. Be sure that the pipes or any other components do not contact any part of the vehicle.
- b. Check for proper hood clearance. Re-adjust pipes if necessary and re-tighten them.
- c. Inspect the engine bay for any loose tools and check that all fasteners that were moved or removed are properly tightened.
- d. Reconnect negative battery terminal and start engine. Let the vehicle idle for 3 minutes. Perform a final inspection before driving the vehicle.

5. Service and Maintenance

- a. AEM Induction Systems requires cleaning the intake system's air filter element every 100,000 miles. When used in dusty or off-road environments, our filters will require cleaning more often. We recommend that you visually inspect your filter once every 25,000 miles to determine if the screen is still visible. When the screen is no longer visible some place on the filter element, it is time to clean it. To clean, purchase our Synthetic air filter cleaner, part number 1-1000 and follow the easy instructions.
- b. Use window cleaner to clean your powder coated AEM[®] intake tube.

NOTE: DO NOT USE aluminum polish on powder coated AEM[®] intake tubes.

For technical inquiries
e-mail us at
sales@aemintakes.com
or
call us at
800.992.3000

AEM Air Intake System Warranty Policy

AEM[®] warrants that its intake systems will last for the life of your vehicle. AEM[®] will not honor this warranty due to mechanical damage (i.e. improper installation or fitment), damage from misuse, accidents or flying debris. AEM[®] will not warrant its powder coating if the finish has been cleaned with a hydrocarbon-based solvent. The powder coating should only be cleaned with a mild soap and water solution. Proof of purchase of both the vehicle and AEM[®] intake system is required for redemption of a warranty claim.

This warranty is limited to the repair or replacement of the AEM[®] part. In no event shall this warranty exceed the original purchase price of the AEM[®] part nor shall AEM[®] be responsible for special, incidental or consequential damages or cost incurred due to the failure of this product. Warranty claims to AEM[®] must be transportation prepaid and accompanied with dated proof of purchase. This warranty applies only to the original purchaser of product and is nontransferable. Improper use or installation, use for racing, accident, abuse, unauthorized repairs or alterations voids this warranty. AEM[®] disclaims any liability for consequential damages due to breach of any written or implied warranty on all products manufactured by AEM[®]. Warranty returns will only be accepted by AEM[®] when accompanied by a valid Return Merchandise Authorization (RMA) number. Credit for defective products will be issued pending inspection. Product must be received by AEM[®] within 30 days of the date RMA is issued.

If you have a warranty issue, please call (800) 992-3000 and our customer service department will assist you. A proof of purchase is required for all AEM[®] warranty claims.