



Equipped with AEM® Dryflow™ Filter
No Oil Required!

INSTALLATION INSTRUCTIONS

PART NUMBER: 21-8000

2002-2006	CADILLAC	Escalade	V8-6.0L	C.A.R.B. E.O. # D-670-6
2002-2005	CADILLAC	Escalade	V8-5.3L	C.A.R.B. E.O. # D-670-6
2002-2006	CHEVROLET	Avalanche 1500	V8-5.3L	C.A.R.B. E.O. # D-670-6
2006	CHEVROLET	Silverado 1500	V8-6.0L	C.A.R.B. E.O. # D-670-6
1999-2006	CHEVROLET	Silverado 1500	V8-5.3L	C.A.R.B. E.O. # D-670-6
1999-2004	CHEVROLET	Silverado 1500	V8-4.8L	C.A.R.B. E.O. # D-670-6
2007	CHEVROLET	Silverado 1500 Classic	V8-5.3L	C.A.R.B. E.O. # D-670-6
2007	CHEVROLET	Silverado 1500 Classic	V8-4.8L	C.A.R.B. E.O. # D-670-6
2001-2003	CHEVROLET	Silverado 1500 HD	V8-6.0L	C.A.R.B. E.O. # D-670-6
2005-2006	CHEVROLET	Silverado 1500 HD	V8-6.0L	C.A.R.B. E.O. # D-670-6
2007	CHEVROLET	Silverado 1500 HD Classic	V8-6.0L	C.A.R.B. E.O. # D-670-6
1999-2004	CHEVROLET	Silverado 2500	V8-6.0L	C.A.R.B. E.O. # D-670-6
1999-2000	CHEVROLET	Silverado 2500	V8-5.3L	C.A.R.B. E.O. # D-670-6
2001-2006	CHEVROLET	Silverado 2500 HD	V8-6.0L	C.A.R.B. E.O. # D-670-6
2007	CHEVROLET	Silverado 2500 HD Classic	V8-6.0L	C.A.R.B. E.O. # D-670-6
2001-2006	CHEVROLET	Silverado 3500	V8-6.0L	C.A.R.B. E.O. # D-670-6
2003-2006	CHEVROLET	Silverado SS	V8-6.0L	C.A.R.B. E.O. # D-670-6
2007	CHEVROLET	Silverado SS Classic	V8-6.0L	C.A.R.B. E.O. # D-670-6
2006	CHEVROLET	Suburban 1500	V8-6.0L	C.A.R.B. E.O. # D-670-6
2000-2006	CHEVROLET	Suburban 1500	V8-5.3L	C.A.R.B. E.O. # D-670-6
2000-2006	CHEVROLET	Suburban 2500	V8-6.0L	C.A.R.B. E.O. # D-670-6
2000-2006	CHEVROLET	Tahoe	V8-5.3L	C.A.R.B. E.O. # D-670-6
2000-2006	CHEVROLET	Tahoe	V8-4.8L	C.A.R.B. E.O. # D-670-6
2001-2003	GMC	Sierra 1500 HD	V8-6.0L	C.A.R.B. E.O. # D-670-6
2005-2006	GMC	Sierra 1500 HD	V8-6.0L	C.A.R.B. E.O. # D-670-6
1999-2006	GMC	Sierra 1500	V8-5.3L	C.A.R.B. E.O. # D-670-6
1999-2006	GMC	Sierra 1500	V8-4.8L	C.A.R.B. E.O. # D-670-6
2007	GMC	Sierra 1500 Classic	V8-5.3L	C.A.R.B. E.O. # D-670-6
2007	GMC	Sierra 1500 Classic	V8-4.8L	C.A.R.B. E.O. # D-670-6
2007	GMC	Sierra 1500 HD Classic	V8-6.0L	C.A.R.B. E.O. # D-670-6
1999-2004	GMC	Sierra 2500	V8-6.0L	C.A.R.B. E.O. # D-670-6
1999-2000	GMC	Sierra 2500	V8-5.3L	C.A.R.B. E.O. # D-670-6
2001-2006	GMC	Sierra 2500 HD	V8-6.0L	C.A.R.B. E.O. # D-670-6
2007	GMC	Sierra 2500 HD Classic	V8-6.0L	C.A.R.B. E.O. # D-670-6
2001-2006	GMC	Sierra 3500	V8-6.0L	C.A.R.B. E.O. # D-670-6
2007	GMC	Sierra 3500 Classic	V8-6.0L	C.A.R.B. E.O. # D-670-6
2000-2006	GMC	Yukon	V8-5.3L	C.A.R.B. E.O. # D-670-6
2000-2006	GMC	Yukon	V8-4.8L	C.A.R.B. E.O. # D-670-6
2002-2006	GMC	Sierra Denali	V8-6.0L	C.A.R.B. E.O. # D-670-6
2007	GMC	Sierra Denali Classic	V8-6.0L	C.A.R.B. E.O. # D-670-6
2001-2006	GMC	Yukon Denali	V8-6.0L	C.A.R.B. E.O. # D-670-6
2001-2006	GMC	Yukon Denali XL	V8-6.0L	C.A.R.B. E.O. # D-670-6
2002-2006	GMC	Yukon XL 1500	V8-5.3L	C.A.R.B. E.O. # D-670-6
2000-2006	GMC	Yukon XL 2500	V8-6.0L	C.A.R.B. E.O. # D-670-6

* **NOTE: Legal in California only for racing vehicles which may never be used upon a highway**

PARTS LIST

Description	Qty.	Part Number
A	1	21-2100DK
B	1	9-7000N
C	1	94104
D	1	20-8013
E	1	1228599
F	4	9464
G	1	5-438
H	1	2-80002
I	2	08160
J	2	444.460.04
K	1	5-490
L	1	20-8511

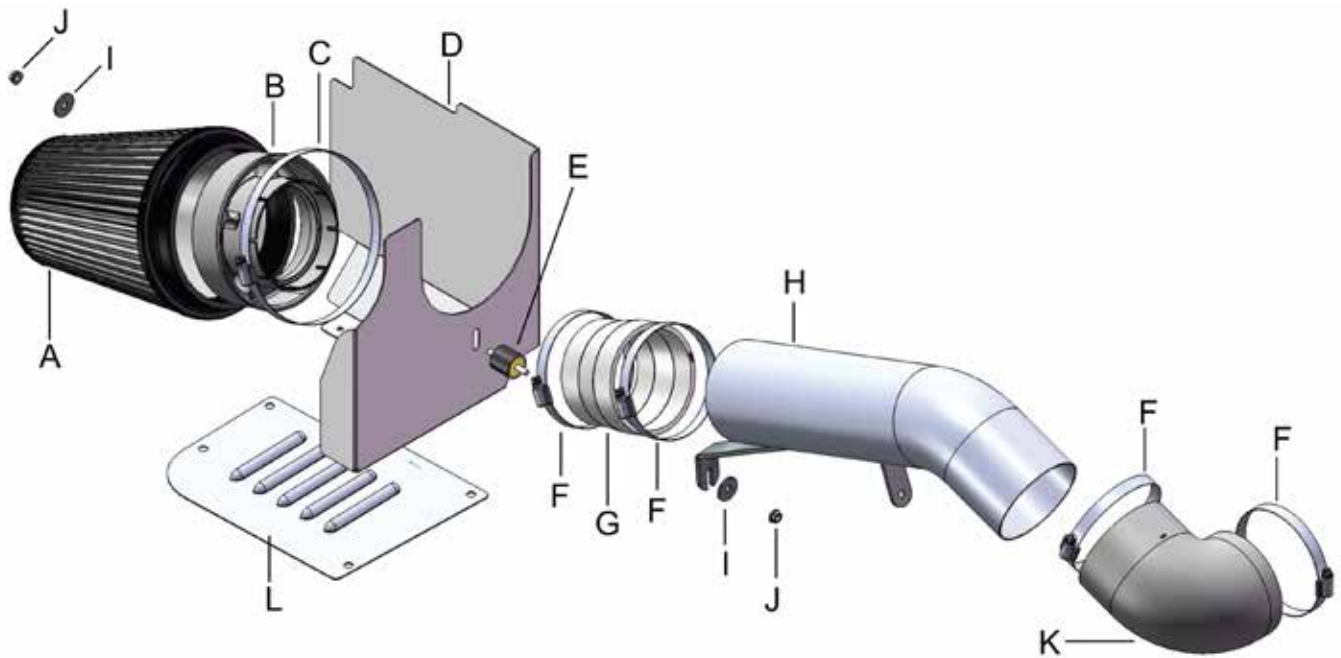

Read and understand these instructions **BEFORE** attempting to install this product. Failure to follow installation instructions and not using the provided hardware may damage the intake tube, throttle body and engine.

1. Preparing Vehicle

- a. Make sure vehicle is parked on level surface.
- b. Set parking brake.
- c. If engine has run in the past two hours, let it cool down.
- d. Disconnect the negative battery terminal.
- e. Do not discard stock components after removal of the factory system.

2. Removal of stock system



a. Stock air box system.



b. Disconnect the mass airflow (MAF) sensor harness.



c. Disconnect the plastic mount securing the radiator hose to the intake duct.



d. Loosen the hose clamp securing the intake duct to the MAF sensor.



e. Remove the bolt securing the engine cover.



f. Remove the engine cover.



g. Loosen the hose clamp securing the intake duct to the throttle body.



h. Pull the intake duct away from the throttle body.



i. Disconnect the intake duct from the MAF sensor.



j. Remove the intake duct from the vehicle.



k. Pull up on the stock air box to disengage it from the plate on the bottom.



l. Remove the stock air box from the vehicle.

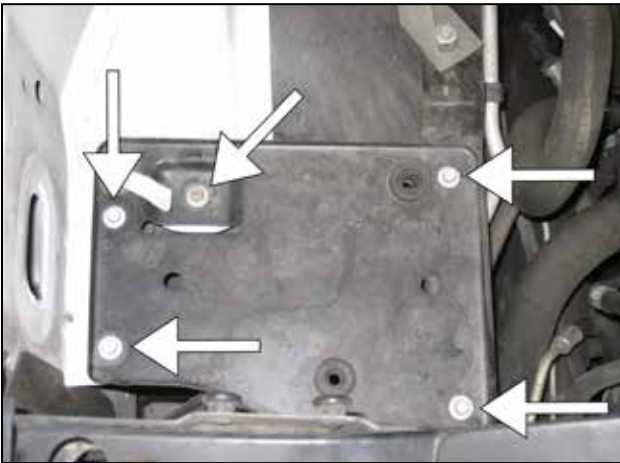

m. Remove the 5 bolts securing the metal air box tray.



n. Remove the tray from the vehicle.



o. Loosen the hose clamp securing the MAF sensor to the stock air box. Remove the MAF sensor from the stock air box.

3. Installation of AEM® intake system.

a. When installing the intake system, do not completely tighten the hose clamps or mounting hardware until instructed to do so.



b. Place the splash shield in the location where the air box tray was and align the holes.



c. Install the two stock bolts to loosely secure the splash shield.



d. Install the heat shield over the splash shield and line up the holes.



e. Install the 3 remaining stock bolts to secure the heatshield and the splash shield.



f. Install the rubber mount using the supplied washer and M6 nut on the heat shield.



g. Install the 90° coupler on the throttle body and loosely secure with the supplied #64 hose clamp.



h. Install the #64 hose clamp on the other end of the coupler.



i. Install the intake pipe into the coupler.



j. Align the bracket with the rubber mount installed in step 3(f).



k. Install the supplied washer and the M6 nut.



l. Assemble the MAF sensor and the supplied adapter as shown.



m. Attach the reducer coupler to the MAF sensor and secure with a supplied #64 hose clamp. Loosely attach another #64 hose clamp to the opposite end of the coupler.



n. Install the MAF sensor assembly (assembled in the previous steps) onto the intake pipe.



o. Reconnect the MAF sensor harness to the MAF sensor.



p. Install the air filter onto the adapter.



q. Secure the plastic mount on the radiator hose to the intake pipe.



AEM® intake system installed

4. Reassemble Vehicle

- a. Position the inlet pipes for the best fitment. Be sure that the pipes or any other components do not contact any part of the vehicle. Tighten the rubber mount, all bolts, and hose clamps.
- b. Check for proper hood clearance. Re-adjust pipes if necessary and re-tighten them.
- c. Inspect the engine bay for any loose tools and check that all fasteners that were moved or removed are properly tightened.
- e. Reconnect negative battery terminal and start engine. Let the vehicle idle for 3 minutes. Perform a final inspection before driving the vehicle.

5. CARB Sticker Placement

- a. The C.A.R.B. exemption sticker, (attached), must be visible under the hood so that an emissions inspector can see it when the vehicle is required to be tested for emissions. California requires testing every two years, other states may vary.
- b. Most General Motors trucks (including Chevrolet) have the Vehicle Emissions Certification Information (VECI) label affixed to the air filter box. In order to be compliant with California emissions laws, the label MUST remain in the engine compartment. If the Vehicle Emission Control Information label is removed during modification, a new replacement label must be obtained and installed in a readily visible position in the engine compartment. The label shall not be affixed to any equipment which is easily detached from the vehicle. We recommend that the label is affixed to the underside of the hood adjacent to the hood latch. The label is Vehicle Identification Number dependent and can be ordered from the vehicle dealership. In order to receive the proper decal please bring your VIN with you. Failure to have the VECI under the hood may result in failure of a pre-registration smog test.

6. Service and Maintenance

- a. AEM Induction Systems requires cleaning the intake system's air filter element every 100,000 miles. When used in dusty or off-road environments, our filters will require cleaning more often. We recommend that you visually inspect your filter once every 25,000 miles to determine if the screen is still visible. When the screen is no longer visible some place on the filter element, it is time to clean it. To clean, purchase our Synthetic air filter cleaner, part number 99-0624 and follow the easy instructions.
- b. Use window cleaner to clean your powder coated AEM® intake tube.

NOTE: DO NOT USE aluminum polish on powder coated AEM® intake tubes.

For technical inquiries
e-mail us at
sales@aemintakes.com
or
call us at
800.992.3000

AEM Air Intake System Warranty Policy

AEM® warrants that its intake systems will last for the life of your vehicle. AEM will not honor this warranty due to mechanical damage (i.e. improper installation or fitment), damage from misuse, accidents or flying debris. AEM will not warrant its powder coating if the finish has been cleaned with a hydrocarbon-based solvent. The powder coating should only be cleaned with a mild soap and water solution. Proof of purchase of both the vehicle and AEM intake system is required for redemption of a warranty claim.

This warranty is limited to the repair or replacement of the AEM part. In no event shall this warranty exceed the original purchase price of the AEM part nor shall AEM be responsible for special, incidental or consequential damages or cost incurred due to the failure of this product. Warranty claims to AEM must be transportation prepaid and accompanied with dated proof of purchase. This warranty applies only to the original purchaser of product and is nontransferable. Improper use or installation, use for racing, accident, abuse, unauthorized repairs or alterations voids this warranty. AEM disclaims any liability for consequential damages due to breach of any written or implied warranty on all products manufactured by AEM. Warranty returns will only be accepted by AEM when accompanied by a valid Return Merchandise Authorization (RMA) number. Credit for defective products will be issued pending inspection. Product must be received by AEM within 30 days of the date RMA is issued.

If you have a warranty issue, please call (800) 992-3000 and our customer service department will assist you. A proof of purchase is required for all AEM warranty claims.