



Equipped with AEM® Dryflow™ Filter  
No Oil Required!

## INSTALLATION INSTRUCTIONS

### PART NUMBER: 21-8005

---

1996-2004	CHEVROLET Blazer	V6-4.3L	C.A.R.B. E.O. # D-670-2
1996-2004	GMC Sonoma	V6-4.3L	C.A.R.B. E.O. # D-670-2
1996-2004	CHEVROLET S10 Pickup	V6-4.3L	C.A.R.B. E.O. # D-670-2
1996-2004	GMC Jimmy	V6-4.3L	C.A.R.B. E.O. # D-670-2

**PARTS LIST**

<b>Description</b>	<b>Qty.</b>	<b>Part Number</b>
Air Filter Assy. 3.50 X 9" Dry Ele.	1	21-2049D
Heat Shield	1	20-8005
Plenum	1	9-8005
Adapter, S10 Plenum - Anodize Black	1	32-3024
Inlet Pipe	1	2-80052C
Hose, Adapter 3.50/3.25x2.50	2	5-352
GROMMET; 1"OD, 1/2"ID, 1/2"THK	1	08064
O-ring, Plenum Adapter	1	8-123
Mount, Rubber 1" X 8mm	1	1228560
Screw, Sheet Metal #12 X .5"	2	1-2085
Hex, Standoff Long - Zinc Silver	2	1-2083
Hex, Standoff Short - Zinc Silver	1	1-2084
Bolt, Hex/Flange M6-1 X 20	3	1-2038
Washer, #12 Int. Tooth Lock	2	1-3034
Washer, 8mm Soft Mount	1	559960
Nut, M8 Hex Serrated	1	444.460.08
1/2" Bnd. Hose Clamp, 3.15"-4.00"	3	9456
1/2" Bnd. Hose Clamp, 2.90"-3.75"	2	9452

Read and understand these instructions **BEFORE** attempting to install this product. Failure to follow installation instructions and not using the provided hardware may damage the intake tube, throttle body and engine.

## 1. Preparing Vehicle

- a. Make sure vehicle is parked on level surface.
- b. Set parking brake.
- c. If engine has run in the past two hours, let it cool down.
- d. Disconnect negative battery terminal.
- e. Jack up the front of the vehicle and support using properly rated jack stands.
- f. Do not discard stock components after removal of the factory system.

## 2. Removal of stock system



a. Factory air box system installed on the vehicle.

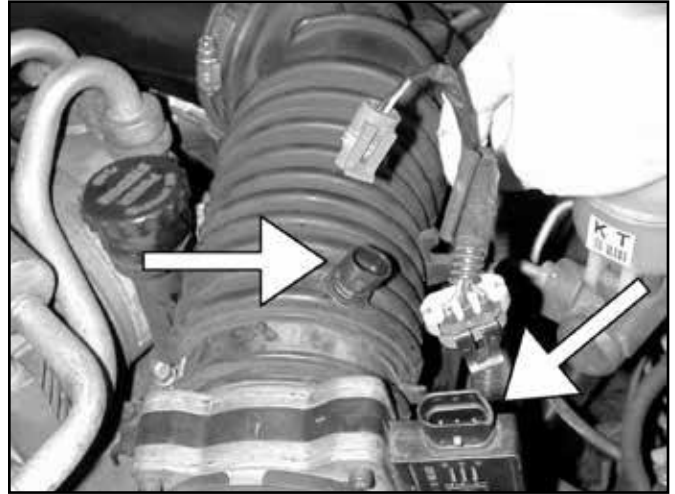

b. Unplug the inlet air temperature (IAT) and mass air flow (MAF) sensors.

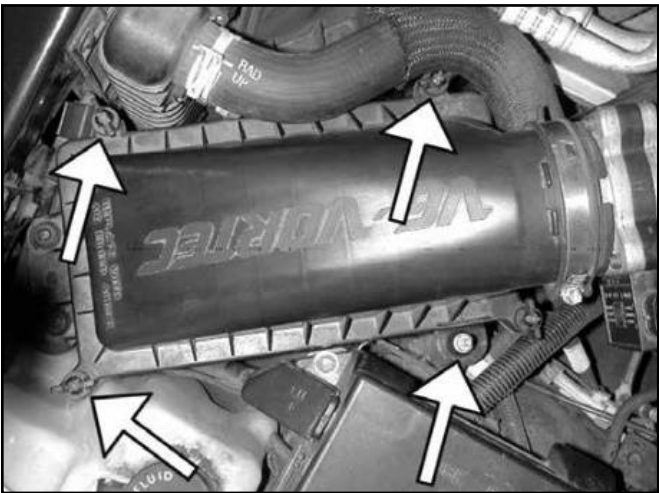

c. Loosen the four wing nuts that secure the air box lid to the lower air box.



d. Loosen the hose clamp securing the stock intake tube to the plastic throttle body adapter. Remove the entire air box lid / MAF sensor / intake tube assembly from the vehicle.

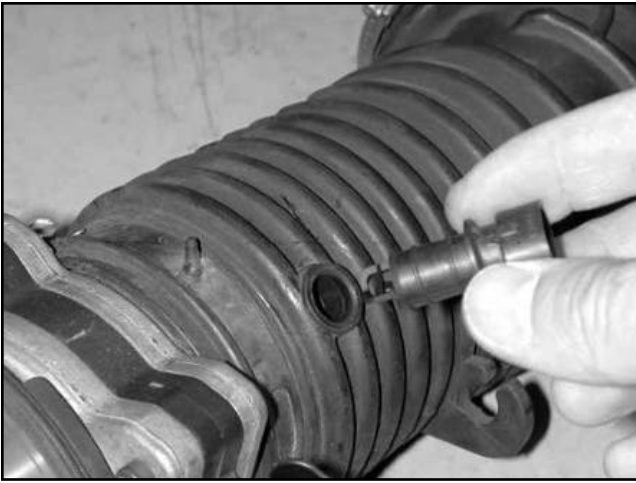

e. Remove the IAT sensor from the stock rubber intake tube. Set the sensor aside for use later in the installation.



f. Loosen the hose clamps on either side of the MAF sensor. Remove the MAF sensor from the assembly and set aside in a safe place. Use care to avoid damaging the screen or any other part of the MAF sensor. The rubber gasket on the air box side of the MAF sensor will not be used with the AEM® intake.

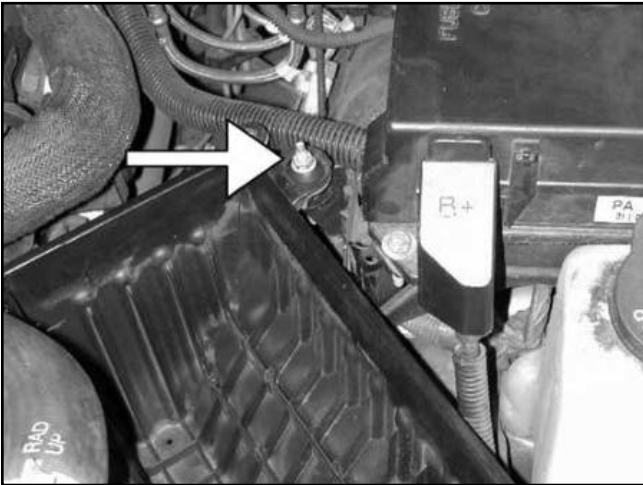

g. Remove the lower air box mounting nut. Remove the lower air box from the vehicle. Remove the lower air box mounting stud. This stud will be replaced with a rubber mount for the AEM® intake pipe later in the installation.



h. Remove the plastic air box mounting bracket located next to the radiator. The bracket is released by sliding it straight up.

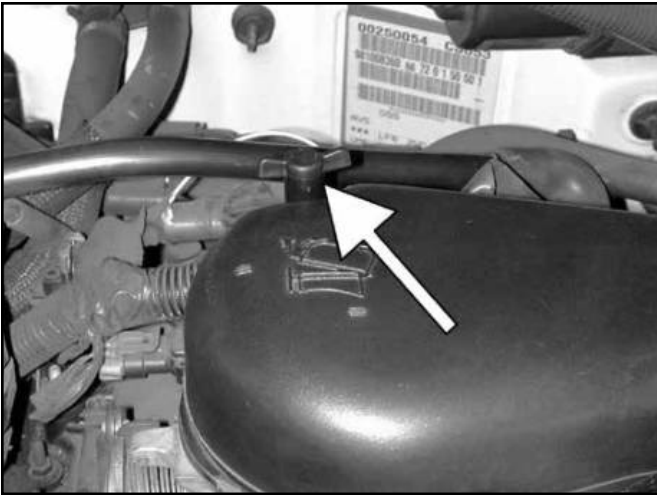

i. Remove the wing nut securing the plastic throttle body adapter to the throttle body.

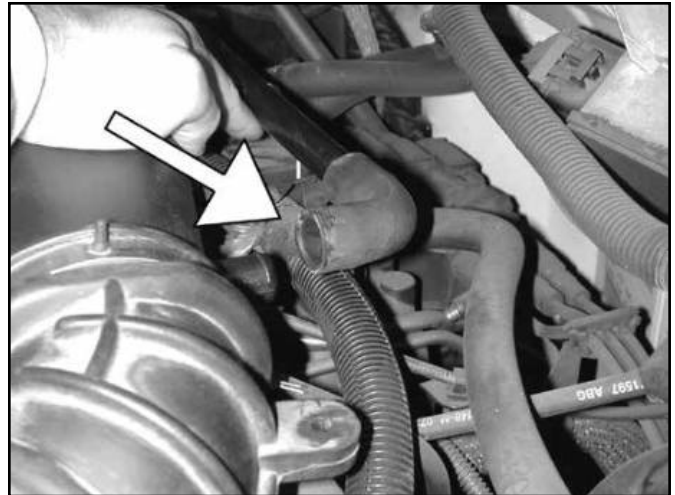

j. Remove the breather hose on the back side of the throttle body adapter.



k. Remove the plastic throttle body adapter from the throttle body.

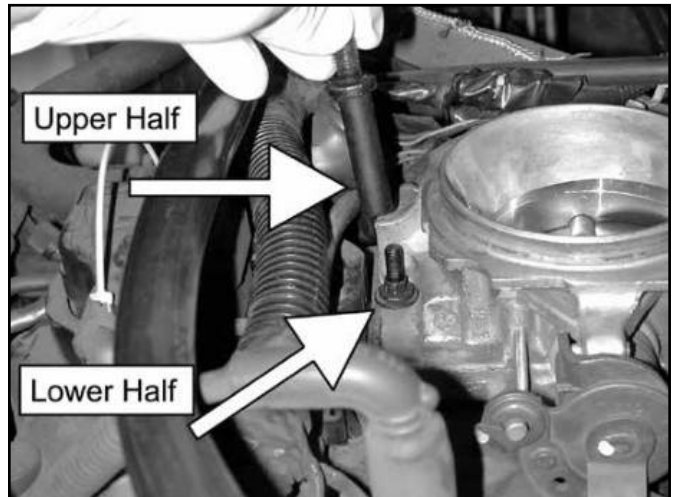

l. Remove the upper half of the stud at the rear (fire-wall side) of the throttle body. If the entire stud comes out as one piece, separate the two halves and reinstall the lower half.

### 3. Installation of AEM® intake system.

- a. When installing the intake system, do not completely tighten the hose clamps or mounting hardware until instructed to do so.

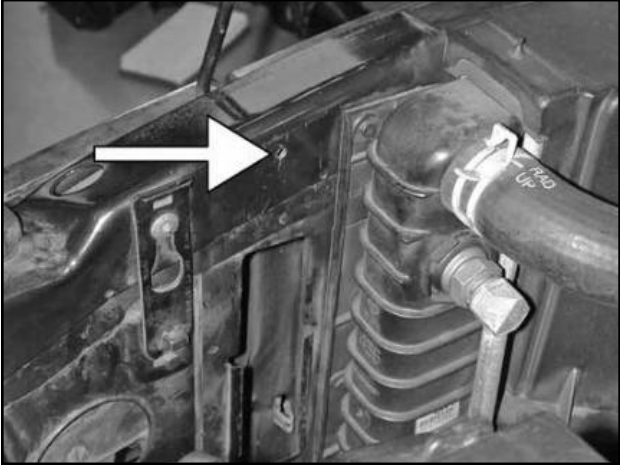

b. Enlarge the existing hole on the backside of the radiator support to 0.188" (3/16" drill).

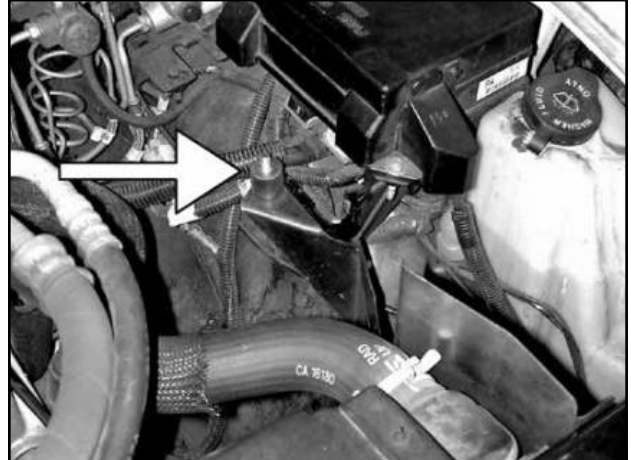

c. Temporarily install the AEM® heat shield using the supplied rubber mount in the hole left open by the lower air box-mounting stud in step 2g. Also install one of the supplied sheet metal screws through the heat shield and into the hole enlarged in the previous step.

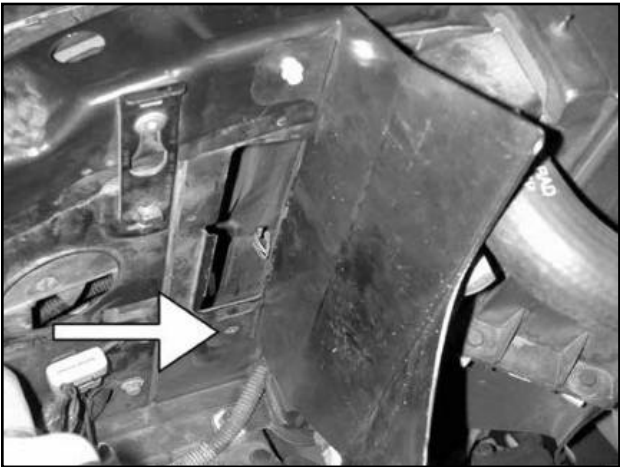

d. Mark and drill a 0.188" (3/16" drill) hole at the lower heat shield mounting location in the radiator support.

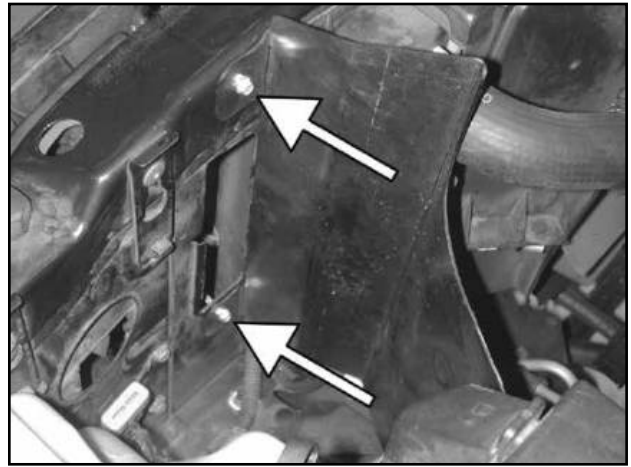

e. Install the remaining sheet metal screw in the lower heat shield mounting location.

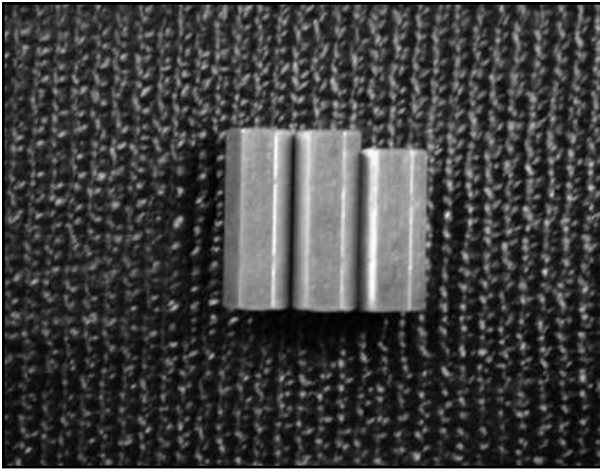

f. Locate the three supplied connector nuts. Make note of the two long connector nuts and one short one.

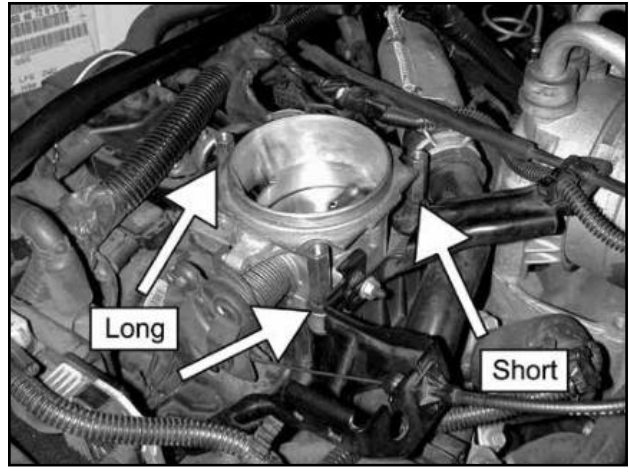

g. Install the three connector nuts according to the diagram above. The one short connector nut goes on the front-left (driver's side) stud where the throttle cable bracket is located.

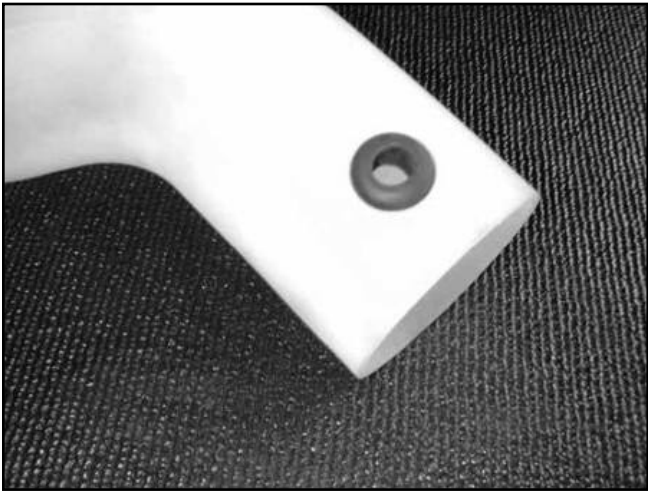

h. Install the supplied IAT rubber grommet into the AEM® plastic intake plenum.

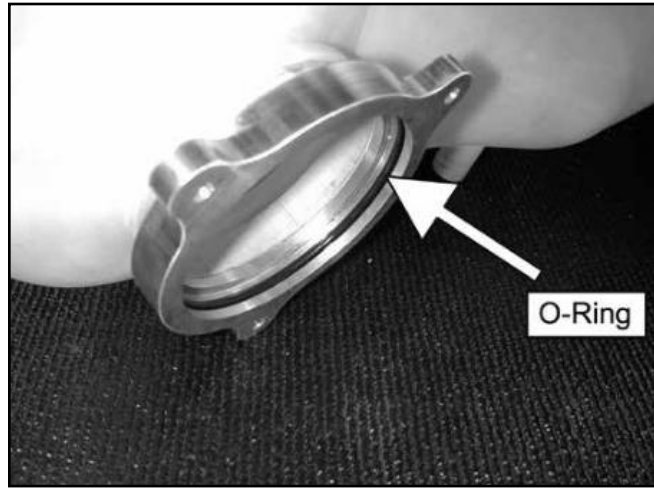

i. Install the supplied o-ring into the groove in the aluminum throttle body adapter. Apply a light coat of clean engine oil to the o-ring to reduce the possibility of damaging it upon installation.

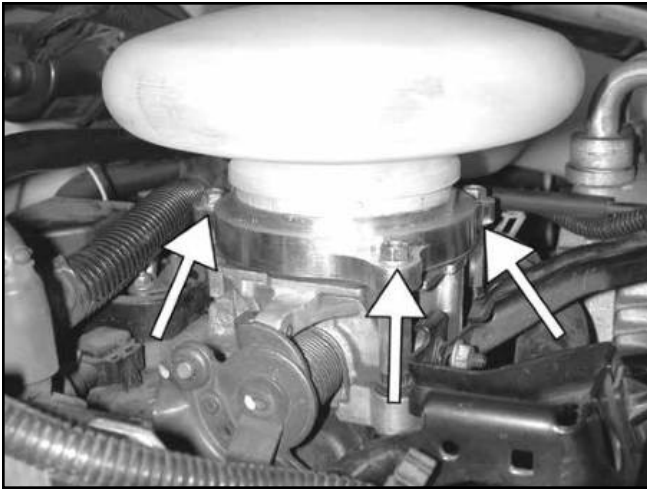

j. Install the throttle body adapter using the three supplied M6x1.0 bolts. Tighten the bolts evenly in an alternating pattern to ensure proper seating of the o-ring.

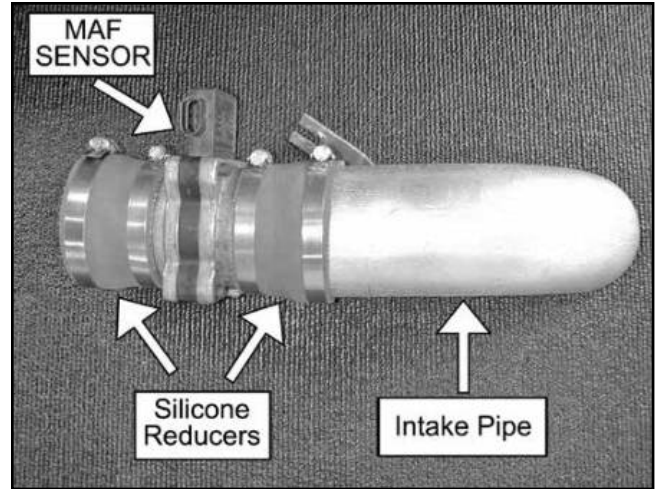

k. Loosely assemble the MAF sensor, silicone reducers, and aluminum AEM® inlet pipe using the supplied hose clamps. Note the orientation of the MAF sensor. The arrow on the MAF sensor points away from the aluminum inlet pipe.



l. Install the AEM® air filter on to the end of the inlet pipe.

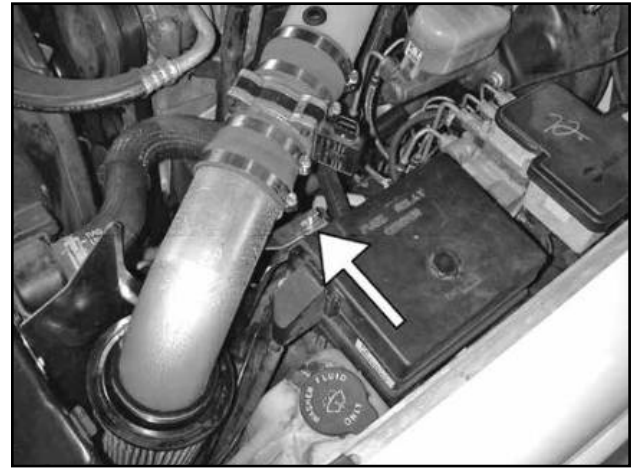

m. Install the assembly into the engine bay. Loosely secure the pipe bracket to the rubber mount using the supplied M8 washer and locknut. Refer to the following diagram on the next page for proper rubber mount installation.

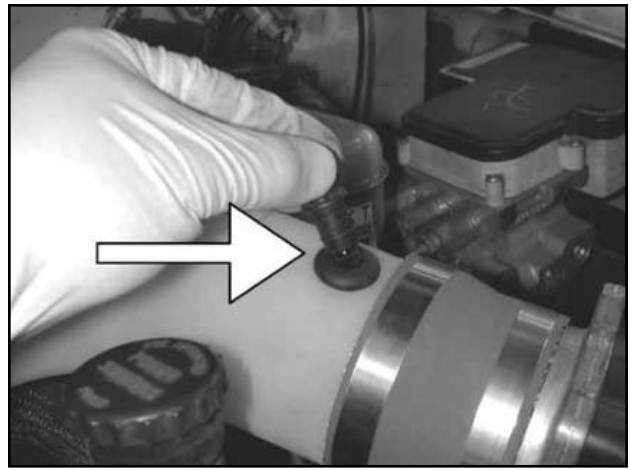
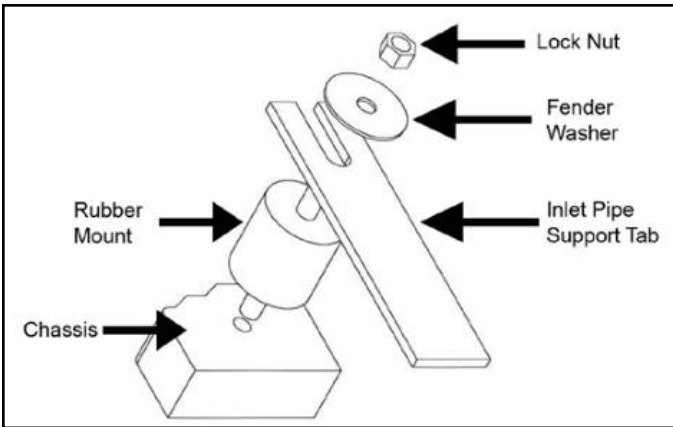

n. Lightly lubricate the IAT grommet to ease installation. Insert the IAT sensor into the grommet using care to avoid pushing the grommet through into the pipe.

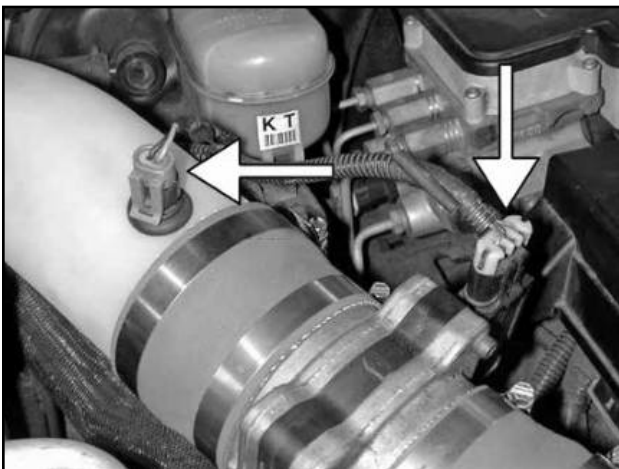

o. Reconnect the IAT and MAF sensor connectors. Failure to reconnect the sensors may result in a check engine light illuminating.

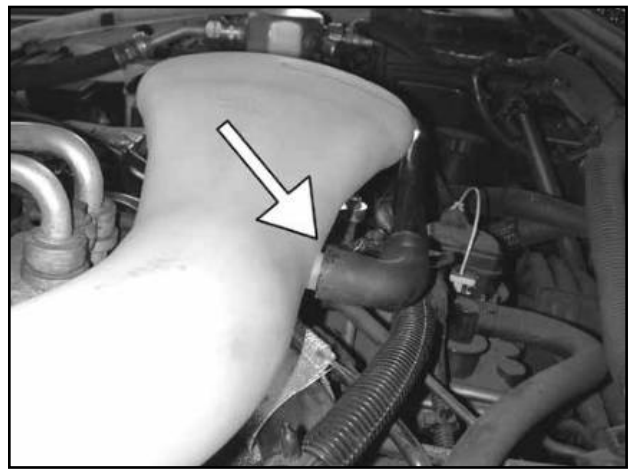

p. Connect the breather hose to the AEM® inlet pleenum.



Factory air box system installed



AEM® intake system installed

#### 4. Reassemble Vehicle

- a. Position the inlet pipes for the best fitment. Be sure that the pipes or any other components do not contact any part of the vehicle. Tighten the rubber mount, all bolts, and hose clamps.
- b. Check for proper hood clearance. Re-adjust pipes if necessary and re-tighten them.
- c. Inspect the engine bay for any loose tools and check that all fasteners that were moved or removed are properly tightened.
- d. Reconnect negative battery terminals and start engine. Let the vehicle idle for 3 minutes. Perform a final inspection before driving the vehicle.

#### 5. CARB Sticker Placement

- a. The C.A.R.B. exemption sticker, (attached), must be visible under the hood so that an emissions inspector can see it when the vehicle is required to be tested for emissions. California requires testing every two years, other states may vary.
- b. Most General Motors trucks (including Chevrolet) have the Vehicle Emissions Certification Information (VECI) label affixed to the air filter box. In order to be compliant with California emissions laws, the label MUST remain in the engine compartment. If the Vehicle Emission Control Information label is removed during modification, a new replacement label must be obtained and installed in a readily visible position in the engine compartment. The label shall not be affixed to any equipment which is easily detached from the vehicle. We recommend that the label is affixed to the underside of the hood adjacent to the hood latch. The label is Vehicle Identification Number dependent and can be ordered from the vehicle dealership. In order to receive the proper decal please bring your VIN with you. Failure to have the VECI under the hood may result in failure of a pre-registration smog test.

#### 6. Service and Maintenance

- a. It is recommended that you service your AEM® Dryflow™ filter every 20,000 miles for optimum performance. Use AEM Dryflow cleaning kit part # 21-110.
- b. Use aluminum polish to clean your polished AEM® intake tube.
- c. Use window cleaner to clean your powder coated AEM® intake tube. **(NOTE: DO NOT USE aluminum polish on powder coated AEM intake tubes).**

For technical inquiries  
e-mail us at  
[sales@aemintakes.com](mailto:sales@aemintakes.com)  
or  
call us at  
800.992.3000

#### AEM Air Intake System Warranty Policy

AEM® warrants that its intake systems will last for the life of your vehicle. AEM will not honor this warranty due to mechanical damage (i.e. improper installation or fitment), damage from misuse, accidents or flying debris. AEM will not warrant its powder coating if the finish has been cleaned with a hydrocarbon-based solvent. The powder coating should only be cleaned with a mild soap and water solution. Proof of purchase of both the vehicle and AEM intake system is required for redemption of a warranty claim.

This warranty is limited to the repair or replacement of the AEM part. In no event shall this warranty exceed the original purchase price of the AEM part nor shall AEM be responsible for special, incidental or consequential damages or cost incurred due to the failure of this product. Warranty claims to AEM must be transportation prepaid and accompanied with dated proof of purchase. This warranty applies only to the original purchaser of product and is nontransferable. Improper use or installation, use for racing, accident, abuse, unauthorized repairs or alterations voids this warranty. AEM disclaims any liability for consequential damages due to breach of any written or implied warranty on all products manufactured by AEM. Warranty returns will only be accepted by AEM when accompanied by a valid Return Merchandise Authorization (RMA) number. Credit for defective products will be issued pending inspection. Product must be received by AEM within 30 days of the date RMA is issued.

If you have a warranty issue, please call (800) 992-3000 and our customer service department will assist you. A proof of purchase is required for all AEM warranty claims.