



Equipped with AEM® Dryflow™ Filter
No Oil Required!

INSTALLATION INSTRUCTIONS

PART NUMBER: 21-8123

2011-2014 FORD Mustang V6-3.7L

**LEGAL IN CALIFORNIA ONLY FOR RACING VEHICLES
WHICH MAY NEVER BE USED, REGISTERED
OR LICENSED FOR USE UPON A HIGHWAY.**

See aemintakes.com for CARB status on each part for a specific vehicle

PARTS LIST

A	Grommet, PCV 3/4"ID 1-3/8"OD	2	784645
B	Bolt, Hex/flange M6-1.0 X 20	1	1-2038
C	Bolt, Button Head M6-1.0 X 10mm	4	1-112
D	Edge Trim, 13"	1	8-4013
E	Airbox Lid; Ford Mustang	1	20-8516
F	PLUG; 1-3/16"OD X .75"ID X 7/16"HT	1	09711
G	Air Box; Ford Mustang	1	9-0394
H	Air Filter	1	21-2148DK
I	Washer; 1"D X 1/4 Hole Fender	2	08160
J	Nut, M6 Hex Serrated	1	444.460.04
K	Bndhose Clamp, 3.15"-4.00"	1	9456
L	Washer, #12 Nylon 6/6	4	1-3001
M	Bolt, Socket M4-.7 X 8mm	2	1-2105
N	Tube; Ford Mustang	1	2-1455
O	Mount,rubber 5/8" X 6mm	1	1228598
P	Plug, Plastic 5/8" X 5/16"	1	8-170
Q	Hose, Adapter 3.00/3.50x3 Blk	1	5-353
R	1/2" Bndhose Clamp, 2.56"-3.50"	1	9448
S	Hose Clamp #6 Mini	1	08407
T	Vacuum Cap, 3/8"	1	8-101
U	1/2 Bndhose Clamp , 3.56"-4.50"	1	9464

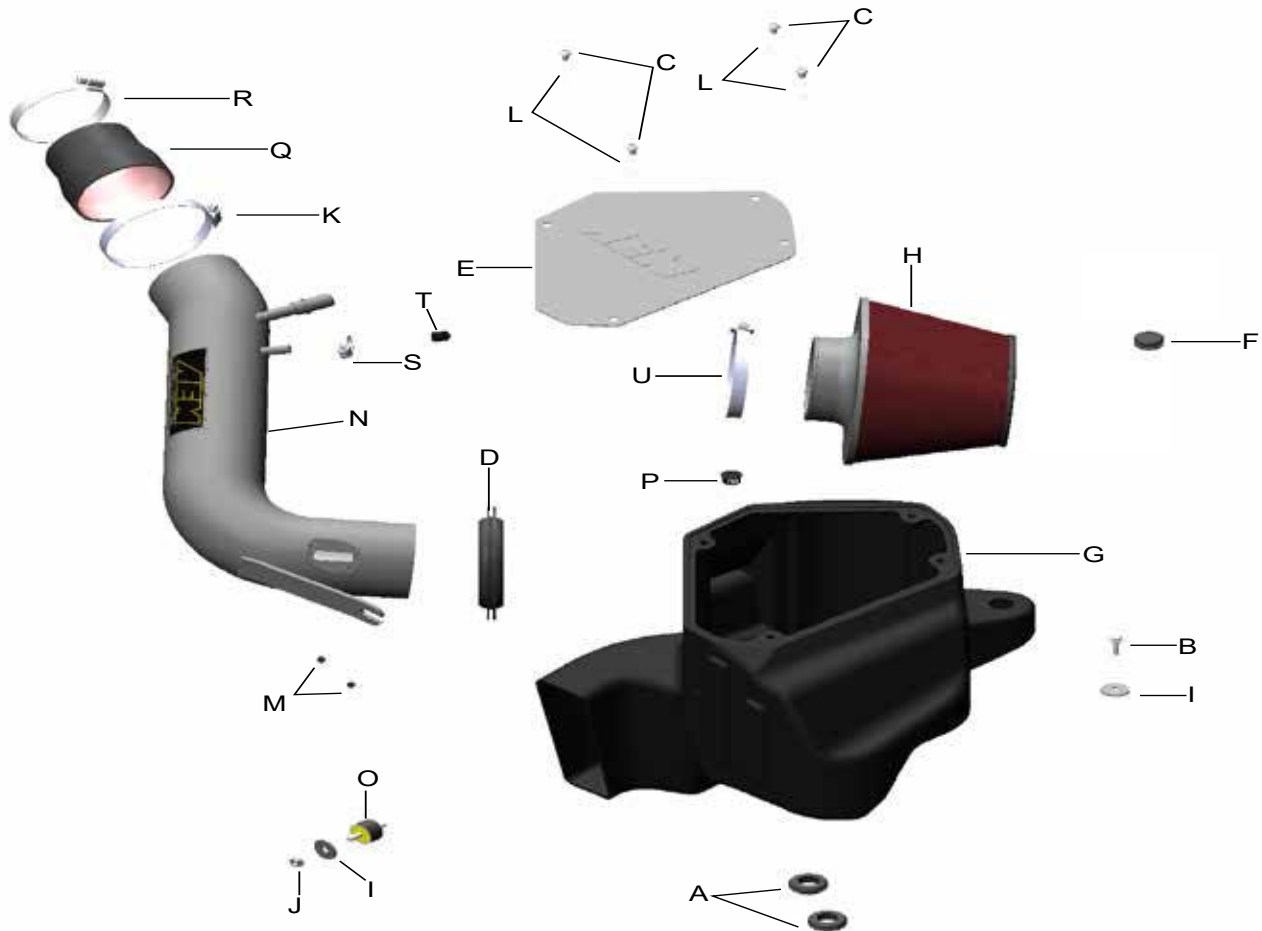

Read and understand these instructions **BEFORE** attempting to install this product. Failure to follow installation instructions and not using the provided hardware may damage the intake tube, throttle body and engine.

1. Preparing Vehicle

- a. Make sure vehicle is parked on level surface.
- b. Set parking brake.
- c. If engine has run in the past two hours, let it cool down.
- d. Disconnect negative battery terminal.
- e. Do not discard stock components after removal of the factory system.

2. Removal of stock system



a. Disconnect the crankcase vent line.



b. Disconnect the brake booster vacuum line.



c. Loosen the hose clamp at the throttle body.



d. Loosen and remove the M6 bolt securing the airbox to the inner fender.



e. Unplug the MAF sensor connector.

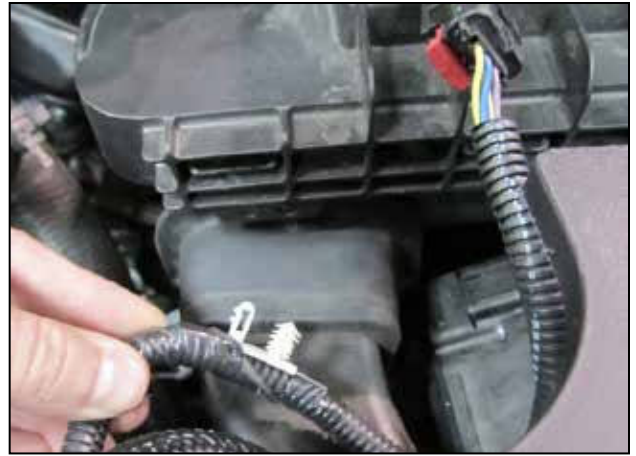

f. Unclip the MAF sensor wire harness from the airbox.



g. Remove the OEM inlet tube off of the throttle body.



h. Lift up and remove the OEM airbox and intake tube from the vehicle.



i. Remove the OEM MAF sensor from the OEM airbox and set it aside for future use.

3. Installation of AEM® Intake System

a. When installing the intake system, do not completely tighten the hose clamps or mounting hardware until instructed to do so.



b. Install the two large grommets (784645) into the holes of the inner fender as shown.



c. Install the supplied edge trim (8-4013) around the edge of the large hole in the airbox as shown. Trim edge trim if necessary.



d. Install the supplied plug (8-170) into the hole on the mounting tab of the airbox.



e. Install the plug (09711) into the filter minder mount of the airbox.



f. Install the supplied rubber mount (1228598) into the threaded insert on the front of the airbox.



g. Lower the airbox assembly into position as shown. Ensure that the bosses on the bottom of the airbox are properly seated in the grommets that were installed in step 3b.



h. Ensure the inlet of the airbox engages the rubber part of the OEM inlet scoop.



i. Install the throttle body coupler using one #48 hose clamp (9448) and one #56 hose clamp (9456).



j. Position the intake pipe as shown. Insert the throttle body end of the pipe into the throttle body coupler as far as it will go.



k. Insert the filter end of the intake pipe through the large hole in the airbox.



l. With the intake pipe properly positioned, ensure the bracket is seated on the stud of the rubber mount.



m. Secure the airbox to the inner fender using the supplied bolt and washer.



n. Install the supplied washer (08160) and M6 nut (444.460.04) on the rubber mount.



o. Install the MAF sensor using the supplied M4 screws (1-2105).



p. Plug the MAF sensor harness connector to the MAF sensor.



q. Install the filter onto the end of the intake pipe and position it as shown. Position the pipe and filter for best fit, and then tighten all clamps and the M6 nut on the rubber mount.



r. Install the airbox lid using the 4 supplied M6 bolts (1-112) and nylon washers (1-3001).



s. Connect the crankcase vent line and the brake booster line to the intake tube. Secure the brake booster line with the supplied clamp (08407). On vehicles that do not have a brake booster line attached to the intake tube, plug the extra nipple on the AEM pipe using the supplied vacuum cap (8-101).

4. Reassemble Vehicle

- a. Position the inlet pipes for the best fitment. Be sure that the pipes or any other components do not contact any part of the vehicle. Tighten the rubber mount, all bolts, and hose clamps.
- b. Check for proper hood clearance. Re-adjust pipes if necessary and re-tighten them.
- c. Inspect the engine bay for any loose tools and check that all fasteners that were moved or removed are properly tightened.
- d. Reconnect the negative battery terminal and start the engine. Let the vehicle idle for 3 minutes. Perform a final inspection before driving the vehicle.

5. Service and Maintenance

- a. It is recommended that you service your AEM® Dryflow™ filter every 20,000 miles for optimum performance. Use AEM Dryflow cleaning kit part # 21-110.
- b. Use aluminum polish to clean your polished AEM® intake tube.
- c. Use window cleaner to clean your powder coated AEM® intake tube. **(NOTE: DO NOT USE aluminum polish on powder coated AEM intake tubes).**

For technical inquiries
e-mail us at
sales@aemintakes.com
or
call us at
800.992.3000

AEM Air Intake System Warranty Policy

AEM® warrants that its intake systems will last for the life of your vehicle. AEM will not honor this warranty due to mechanical damage (i.e. improper installation or fitment), damage from misuse, accidents or flying debris. AEM will not warrant its powder coating if the finish has been cleaned with a hydrocarbon-based solvent. The powder coating should only be cleaned with a mild soap and water solution. Proof of purchase of both the vehicle and AEM intake system is required for redemption of a warranty claim.

This warranty is limited to the repair or replacement of the AEM part. In no event shall this warranty exceed the original purchase price of the AEM part nor shall AEM be responsible for special, incidental or consequential damages or cost incurred due to the failure of this product. Warranty claims to AEM must be transportation prepaid and accompanied with dated proof of purchase. This warranty applies only to the original purchaser of product and is nontransferable. Improper use or installation, use for racing, accident, abuse, unauthorized repairs or alterations voids this warranty. AEM disclaims any liability for consequential damages due to breach of any written or implied warranty on all products manufactured by AEM. Warranty returns will only be accepted by AEM when accompanied by a valid Return Merchandise Authorization (RMA) number. Credit for defective products will be issued pending inspection. Product must be received by AEM within 30 days of the date RMA is issued.

If you have a warranty issue, please call (800) 992-3000 and our customer service department will assist you. A proof of purchase is required for all AEM warranty claims.

**LEGAL IN CALIFORNIA ONLY FOR RACING VEHICLES
WHICH MAY NEVER BE USED, REGISTERED
OR LICENSED FOR USE UPON A HIGHWAY.**

See aemintakes.com for CARB status on each part for a specific vehicle