



Equipped with AEM® Dryflow™ Filter
No Oil Required!

INSTALLATION INSTRUCTIONS

PART NUMBER: 21-8219

2005-2010	CHRYSLER	300C	V8-6.1L	C.A.R.B. E.O. # D-670-6
2006-2008	DODGE	Charger	V8-6.1L	C.A.R.B. E.O. # D-670-6
2005-2008	DODGE	Magnum	V8-6.1L	C.A.R.B. E.O. # D-670-6

* **NOTE:** Legal in California only for racing vehicles which may never be used upon a highway

PARTS LIST

	Description	Qty.	Part Number
A	Element Parts Kit 6.00 X 5"	1	21-209EDK
B	Inlet Pipe, LX 6.1L V8	1	2-P4510947
C	Heat Shield	1	20-P4510832
D	Elbow, 3.50/4.00 90 Deg. w/Hole	1	5-3549H
E	Adapter, Nylon A/F 4" Inlet / 6" Filter	1	9-0372
F	Hose, Silicone 4.00x2" Black	1	5-402
G	Hose; 1/2"ID X 9"L	1	5-5009
H	Edge Trim, 10"	1	8-4010
I	Rubber Edge Trim 16"	1	8-3016
J	Clip, Plastic Push In 0.300"	1	8-149
K	Mount, Rubber 1" X 8mm	1	1228560
L	Washer, 8mm Soft Mount	2	559960
M	Nut, M8 Hex Serrated	2	444.460.08
N	1/2" Bnd. Hose Clamp, 4.125-7.00"	1	94104
O	1/2" Bnd. Hose Clamp, 3.56"-4.50"	3	9464
P	1/2" Bnd. Hose Clamp, 3.15"-4.00"	1	9456
Q	Hose Clamp #6 Mini	2	08407

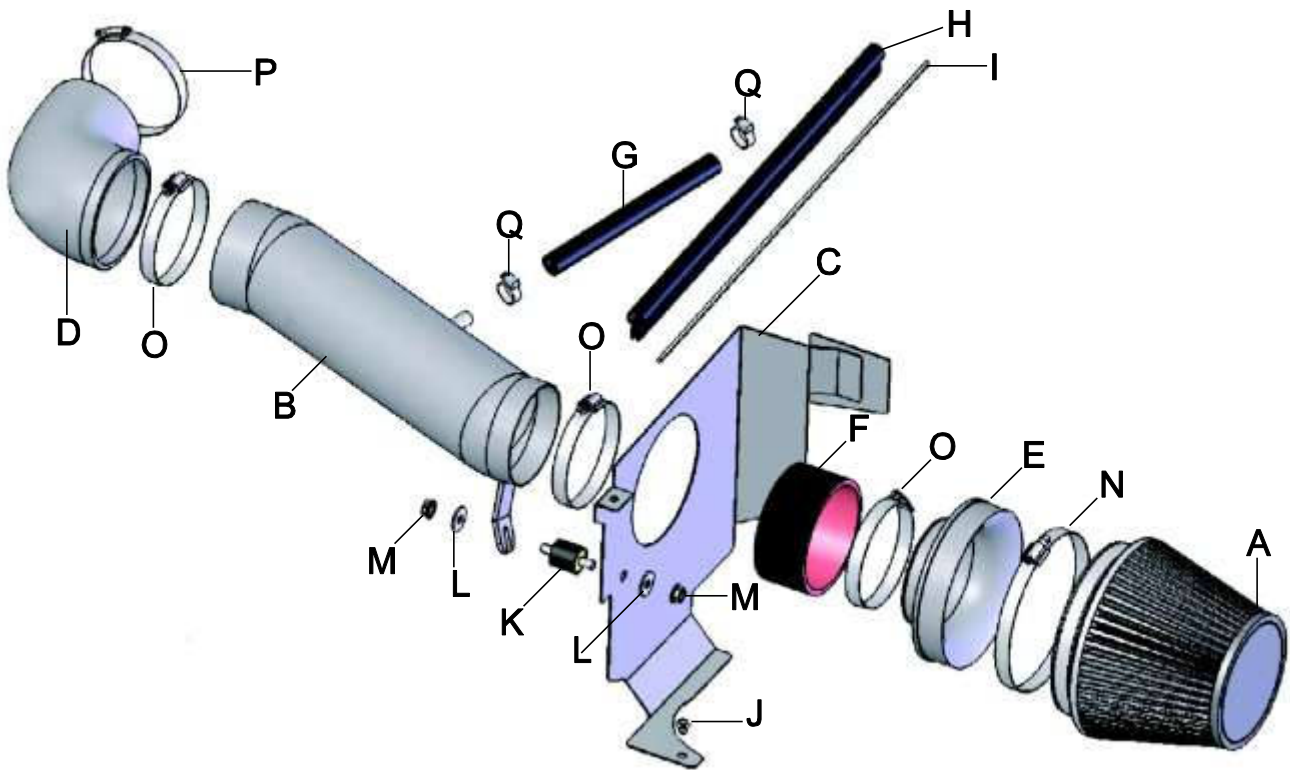

Read and understand these instructions **BEFORE** attempting to install this product. Failure to follow installation instructions and not using the provided hardware may damage the intake tube, throttle body and engine.

1. Preparing Vehicle

- a. Make sure vehicle is parked on level surface.
- b. Set parking brake.
- c. If engine has run in the past two hours, let it cool down.
- d. Disconnect the negative battery terminal.
- e. Do not discard stock components after removal of the factory system.

2. Removal of stock system



a. Stock air box system installed.



b. Loosen the throttle body hose clamp.

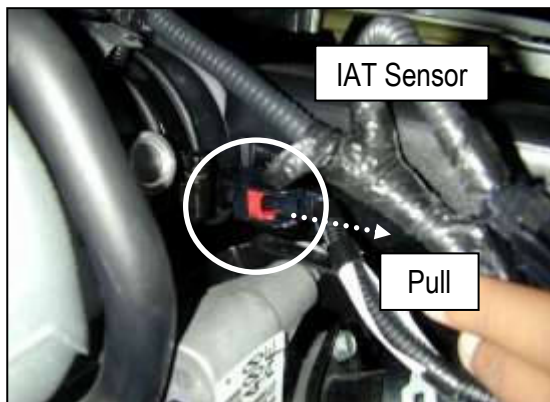

c. Disconnect the inlet air temperature (IAT) sensor by first pulling the tab away from the sensor. Then push in on the clip to disconnect. Remove the sensor from the inlet tube by gently pulling away from the tube.



d. Loosen the inlet tube hose clamp. Remove the inlet tube.

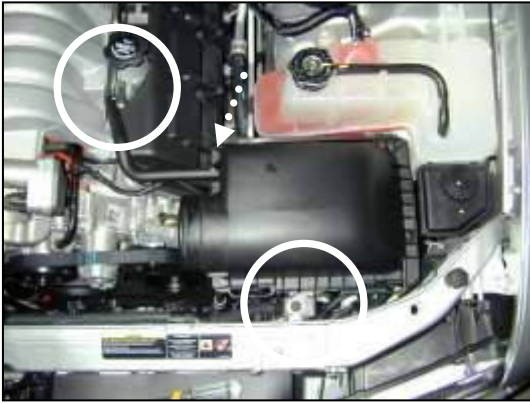

e. Disconnect the crank case breather tube at the intake manifold. Loosen and remove the air box mounting bolt. Remove the air box by pulling straight up.



f. Loosen and remove the nut. Remove bracket and reinstall the nut.

3. Installation of AEM[®] intake system.

a. When installing the intake system, do not completely tighten the hose clamps or mounting hardware until instructed to do so.



b. Attach the rubber edge trim to the inlet pipe opening on the heat shield. Trim excess.



c. Attach the foam gasket onto the top of the heat shield. Trim excess.



d. Insert the heat shield as shown. The vertical tab slides into the coolant reservoir. The bottom tab slides underneath the coolant and vacuum lines.



f. Secure the remaining tab with the factory screw.



h. Secure the rubber mount with the M8 washer and nut.

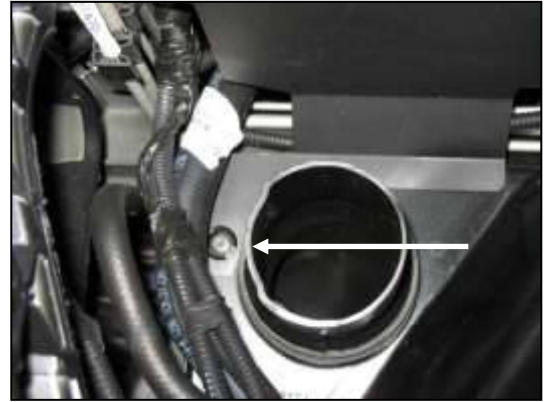

e. Insert the push-in clip on the heat shield base to secure.



g. Insert the rubber mount as shown.

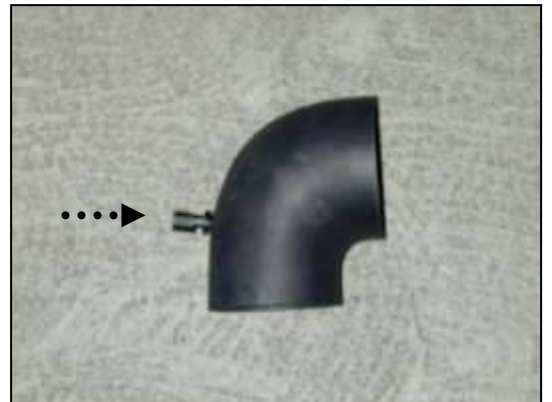

i. Insert the IAT sensor into the coupler. Be careful not to damage the sensor.



j. Attach the smaller end of the coupler to the throttle body and secure with provided hose clamp as shown. Reconnect the IAT sensor wire harness connector and lock in place.



k. Insert inlet pipe as shown. Align the bracket to the rubber mount.



l. Insert the adapter into the filter element. Secure with hose clamp.



m. Attach the coupler and hose clamps to intake pipe and then secure.



n. Attach the air filter assembly to the coupler and secure with hose clamps.



o. Attach the new crank case breather hose to the inlet pipe. Tighten provided hose clamp to secure.



p. Attach the new crank case breather hose to the intake manifold. Tighten provided hose clamp to secure.



AEM® intake system installed

4. Reassemble Vehicle

- a. Position the inlet pipes for the best fitment. Be sure that the pipes or any other components do not contact any part of the vehicle. Tighten the rubber mount, all bolts, and hose clamps.
- b. Check for proper hood clearance. Re-adjust pipes if necessary and re-tighten them.
- c. Inspect the engine bay for any loose tools and check that all fasteners that were moved or removed are properly tightened.
- d. Reconnect negative battery terminal and start engine. Let the vehicle idle for 3 minutes. Perform a final inspection before driving the vehicle.

5. CARB Sticker Placement

- a. The C.A.R.B. exemption sticker, (attached), must be visible under the hood so that an emissions inspector can see it when the vehicle is required to be tested for emissions. California requires testing every two years, other states may vary.

6. Service and Maintenance

- a. AEM Induction Systems requires cleaning the intake system's air filter element every 100,000 miles. When used in dusty or off-road environments, our filters will require cleaning more often. We recommend that you visually inspect your filter once every 25,000 miles to determine if the screen is still visible. When the screen is no longer visible some place on the filter element, it is time to clean it. To clean, purchase our Synthetic air filter cleaner, part number 99-0624 and follow the easy instructions.
- b. Use window cleaner to clean your powder coated AEM[®] intake tube.

NOTE: DO NOT USE aluminum polish on powder coated AEM[®] intake tubes.

For technical inquiries e-mail us at sales@aemintakes.com or call us at 800.992.3000

AEM Air Intake System Warranty Policy

AEM[®] warrants that its intake systems will last for the life of your vehicle. AEM will not honor this warranty due to mechanical damage (i.e. improper installation or fitment), damage from misuse, accidents or flying debris. AEM will not warrant its powder coating if the finish has been cleaned with a hydrocarbon-based solvent. The powder coating should only be cleaned with a mild soap and water solution. Proof of purchase of both the vehicle and AEM intake system is required for redemption of a warranty claim.

This warranty is limited to the repair or replacement of the AEM part. In no event shall this warranty exceed the original purchase price of the AEM part nor shall AEM be responsible for special, incidental or consequential damages or cost incurred due to the failure of this product. Warranty claims to AEM must be transportation prepaid and accompanied with dated proof of purchase. This warranty applies only to the original purchaser of product and is nontransferable. Improper use or installation, use for racing, accident, abuse, unauthorized repairs or alterations voids this warranty. AEM disclaims any liability for consequential damages due to breach of any written or implied warranty on all products manufactured by AEM. Warranty returns will only be accepted by AEM when accompanied by a valid Return Merchandise Authorization (RMA) number. Credit for defective products will be issued pending inspection. Product must be received by AEM within 30 days of the date RMA is issued.

If you have a warranty issue, please call (800) 992-3000 and our customer service department will assist you. A proof of purchase is required for all AEM warranty claims.