



INTAKE SYSTEM

INSTALLATION INSTRUCTIONS

21-825DS

BMW

2007-10 335i

2009-10 335i xDrive

2011-12 M1

2007-08 335xi

2011-14 335is

2007-10 535i

2008-10 535i xDrive

2010-17 Z4

2013-17 Z4 sDrive 35i

2007-08 328xi

L6-3.0L Turbo

NOT LEGAL FOR SALE OR USE ON ANY POLLUTION CONTROLLED MOTOR VEHICLE IN CALIFORNIA OR STATES ADOPTING CALIFORNIA EMISSION PROCEDURES.

See aemintakes.com for CARB status on each part for a specific vehicle

TOOLS NEEDED:

Flat blade screw driver
10mm wrench
ratchet
extension
6mm socket
4mm allen

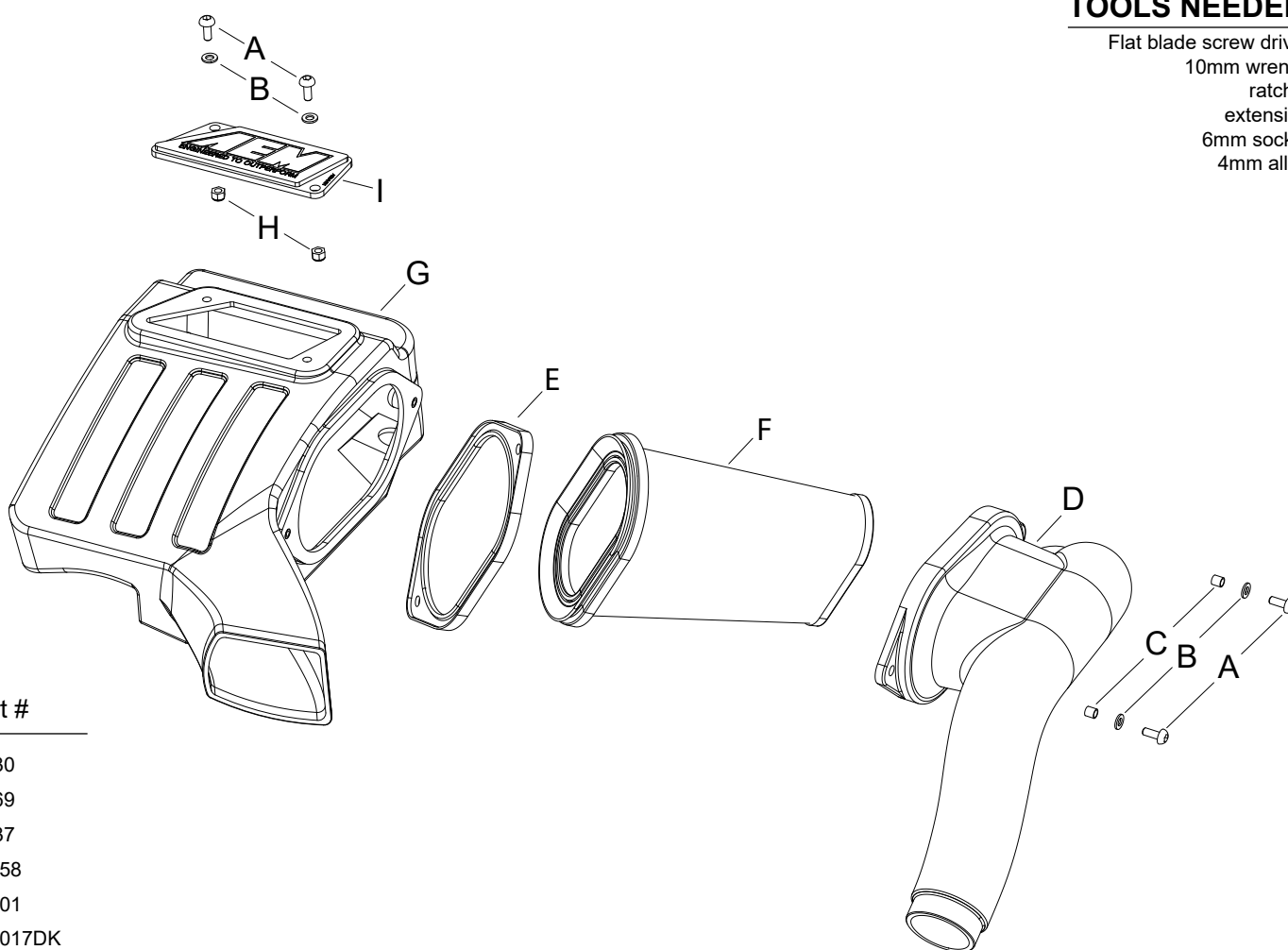

PARTS LIST:

	Description	Qty.	Part #
A	BOLT; M6 X 1.00 X 16MM, SS	4	07730
B	WASHER; 6MM FLAT, SS	4	08269
C	SPACER; ALUM, .25"ID	2	06537
D	TUBE; INTAKE	1	9-0458
E	HOUSING GASKET	1	2-9301
F	FILTER 7-1/2 X 4-1/2B, 5-1/2	1	21-1017DK
G	AIRBOX; BMW 335i 2007-2011	1	9-0457
H	NUT; 6MM NYLOCK, HEXHEAD	2	07512
I	PLATE; AEM LOGO, CLEAR	1	8-211-1

If you need any assistance please call 1-800-858-3333 to speak with a representative in our Customer Service Center before returning the product.

Read and understand these instructions **BEFORE** attempting to install this product. Failure to follow installation instructions and not using the provided hardware may damage the intake tube, throttle body and engine.

TO START:

1. Turn off the ignition and disconnect the negative battery cable.

NOTE: Disconnecting the negative battery cable erases pre-programmed electronic memories. Write down all memory settings before disconnecting the negative battery cable. Some radios will require an anti-theft code to be entered after the battery is reconnected. The anti-theft code is typically supplied with your owner's manual. In the event your vehicles anti-theft code cannot be recovered, contact an authorized dealership to obtain your vehicles anti-theft code.



2. Unclip the four wiring harness guide retaining clips and then remove the upper wiring harness guide.



3. Remove the wiring from the lower guide and then unclip the three lower guide retaining clips and remove the lower guide from the vehicle.



4. Unclip the rear wiring harness to release and then pull the harness forward.



5. Squeeze the sides of the vacuum breather hose connection and disconnect.



6. Remove the rubber wiring harness mounts from the rear of the air filter housing by pulling up to disengage.



7. Loosen the hose clamps that secure the intake tubes to the factory air filter housing.



8. Disconnect the fresh air intake duct from the air filter housing.



9. Pull the factory air filter housing straight upwards to dislodge it from the mounting grommets and then remove it from the vehicle.

NOTE: AEM recommends that customers do not discard factory air intake.



10. Remove the three mounting grommets from the factory air filter housing and install them into the AEM air filter housing as shown.



11. Install the AEM badge into the AEM air filter housing and secure with the provided hardware.



12. Install the two provided bushings into the AEM tube assembly as shown.



13. Install the AEM air filter into the tube assembly as shown.



14. Place the provided gasket onto the tube assembly and then install the tube assembly into the AEM housing and secure with the provided hardware.



15. Install the AEM intake assembly onto the factory mounting pins, then align and connect the fresh air intake duct. Connect the factory intake tubes to the AEM housing and then secure with the factory hose clamps.



16. Reconnect the vacuum breather hose.



17. Use the provided tie wraps and secure the wiring as shown.



Reassemble Vehicle

Position the inlet pipes for the best fitment. Be sure that the pipes or any other components do not contact any part of the vehicle. Tighten the rubber mount, all bolts, and hose clamps. Check for proper hood clearance. Re-adjust pipes if necessary and re-tighten them. Inspect the engine bay for any loose tools and check that all fasteners that were moved or removed are properly tightened. Reconnect negative battery terminal and start engine. Let the vehicle idle for 3 minutes. Perform a final inspection before driving the vehicle.

Service and Maintenance

AEM Induction Systems requires cleaning the intake system's air filter element every 100,000 miles. When used in dusty or off-road environments, our filters will require cleaning more often. We recommend that you visually inspect your filter once every 25,000 miles to determine if the screen is still visible. When the screen is no longer visible some place on the filter element, it is time to clean it. To clean, purchase our Synthetic air filter cleaner, part number AEM-1-1000 and follow the easy instructions. Use window cleaner to clean your powder coated AEM intake tube.

NOTE: DO NOT USE aluminum polish on powder coated AEM intake tubes.

NOT LEGAL FOR SALE OR USE ON ANY POLLUTION CONTROLLED MOTOR VEHICLE IN CALIFORNIA OR STATES ADOPTING CALIFORNIA EMISSION PROCEDURES.

See aemintakes.com for CARB status on each part for a specific vehicle

AEM Air Intake System Warranty Policy

AEM warrants that its intake systems will last for the life of your vehicle. AEM will not honor this warranty due to mechanical damage (i.e. improper installation or fitment), damage from misuse, accidents or flying debris. AEM will not warrant its powder coating if the finish has been cleaned with a hydrocarbon-based solvent. The powder coating should only be cleaned with a mild soap and water solution. Proof of purchase of both the vehicle and AEM intake system is required for redemption of a warranty claim.

This warranty is limited to the repair or replacement of the AEM part. In no event shall this warranty exceed the original purchase price of the AEM part nor shall AEM be responsible for special, incidental or consequential damages or cost incurred due to the failure of this product. Warranty claims to AEM must be transportation prepaid and accompanied with dated proof of purchase. This warranty applies only to the original purchaser of product and is nontransferable. Improper use or installation, use for racing, accident, abuse, unauthorized repairs or alterations voids this warranty. AEM disclaims any liability for consequential damages due to breach of any written or implied warranty on all products manufactured by AEM. Warranty returns will only be accepted by AEM when accompanied by a valid Return Merchandise Authorization (RMA) number. Credit for defective products will be issued pending inspection. Product must be received by AEM within 30 days of the date RMA is issued.

If you have a warranty issue, please call (800) 992-3000 and our customer service department will assist you. A proof of purchase is required for all AEM warranty claims.