



INTAKE SYSTEM

INSTALLATION INSTRUCTIONS

21-827C (Gun Metal Gray Finish)

TOYOTA / LEXUS

2018-22 Camry

2019-22 Avalon

2019-22 ES350

V6-3.5L

NOT LEGAL FOR SALE OR USE ON ANY POLLUTION CONTROLLED MOTOR VEHICLE IN CALIFORNIA OR STATES ADOPTING CALIFORNIA EMISSION PROCEDURES.

See aemintakes.com for CARB status on each part for a specific vehicle

TOOLS NEEDED:

Ratchet
Extension
10mm socket
flat blade screw driver
Phillips screw driver
4mm allen
5mm allen

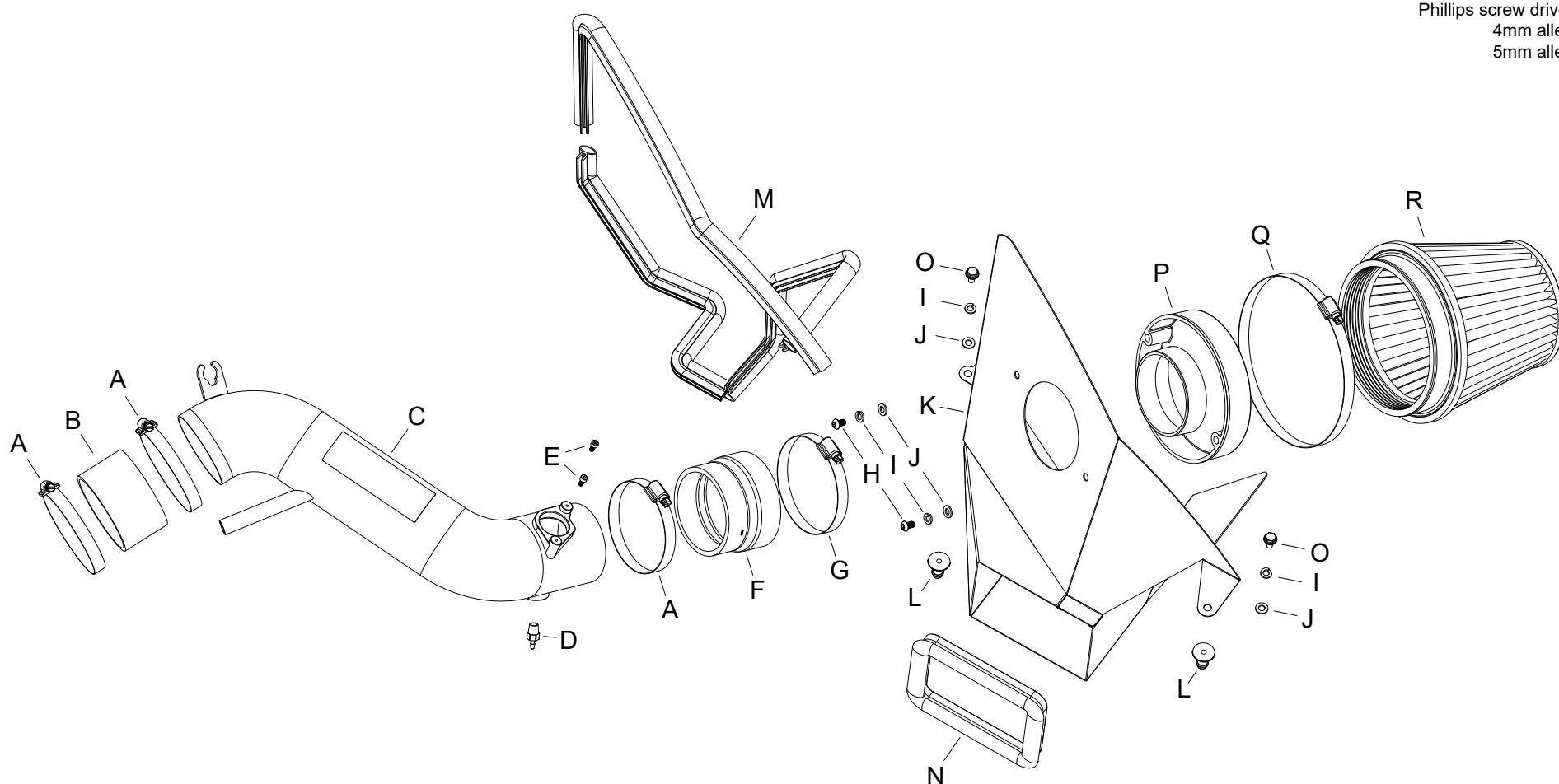

PARTS LIST:

Description	Qty.	Part #	Description	Qty.	Part #	Description	Qty.	Part #
A HOSE CLAMP #52	3	08610	G HOSE CLAMP #56	1	08620	M EDGE TRIM (55")	1	102480A
B HOSE, SILICONE 3.25 X 2.0"	1	5-326	H BOLT; M6 X 1.00 X 16MM, SS	2	07730	N EDGE TRIM (20")	1	102476
C INTAKE TUBE	1	2-1602C	I WASHER, M6 SPLIT LOCK ZINC	4	1-3025	O BOLT; 6MM-1.00 X 16MM, SS	2	07812
D HOSE MENDER; 1/8" BARBED	1	087016	J WASHER; 6MM FLAT, SS	4	08269	P ADAPTER; UNIVERSAL, 6"	1	21512-1
E BOLT; M4 X .7 X 8MM, BUTTON	2	07741	K HEAT SHIELD	1	20-8604	Q 1/2" BNDHOSE CLAMP, 4.125	1	94104
F HOSE; ADAPTER 3.5"/3.25"	1	5-352	L MOUNT, PLASTIC AIRBOX	2	8-186-1	R FILTER	1	21-209EDK

If you need any assistance please call 1-800-858-3333 to speak with a representative in our Customer Service Center before returning the product.

Read and understand these instructions BEFORE attempting to install this product. Failure to follow installation instructions and not using the provided hardware may damage the intake tube, throttle body and engine.

TO START:

1. Turn off the ignition and disconnect the negative battery cable.

NOTE: Disconnecting the negative battery cable erases pre-programmed electronic memories. Write down all memory settings before disconnecting the negative battery cable. Some radios will require an anti-theft code to be entered after the battery is reconnected. The anti-theft code is typically supplied with your owner's manual. In the event your vehicles anti-theft code cannot be recovered, contact an authorized dealership to obtain your vehicles anti-theft code.



2. Remove the five push pins that secure the radiator cover and then remove the radiator cover.



3. Remove the two bolts that secure the fresh air intake duct and then remove the duct from the vehicle.



4. Disconnect the mass air sensor electrical connection and unclip the wiring harness from the air filter housing.



5. Loosen the hose clamps that secure the intake tube to the throttle body and air filter housing, unhook the vent lines attached to the intake tube and then remove the tube from the vehicle.



6. Lift up the air filter housing to dislodge it from the mounting grommets and then remove the housing from the vehicle.

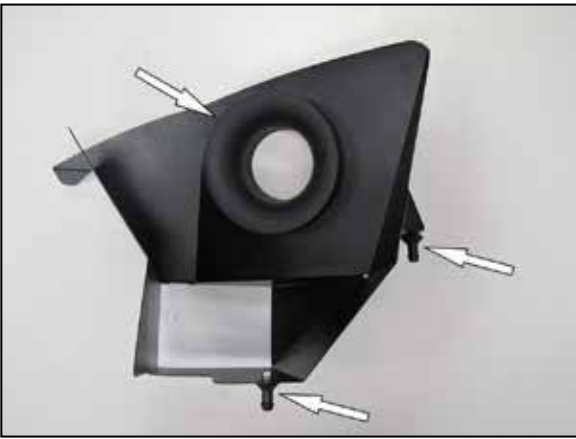

7. Install the two mounting studs and filter adapter onto the heat shield and secure with the provided hardware.



8. Cut the provided top bulb edge trim into sections of 21-1/2", 16" and 14" and then install them onto the heat shield as shown.



9. Install the side bulb edge trim onto the heat shield as shown.



10. Install the provided air filter and coupling hose (5-352) onto the filter adapter and secure with the provided hose clamps.



11. Install the heat shield assembly into the vehicle so the mounting studs engage the factory mounting grommets.



12. Install the provided coupler hose (5-326) onto the throttle body and secure with the provided hose clamp.



13. Install the fresh air intake duct and secure with the factory hardware.



14. Reinstall the radiator cover and secure with the factory push clips.



15. Remove the mass air sensor from the factory air filter housing and install it into the AEM® intake tube using the provided hardware. Install the provided vacuum fitting into the AEM® intake tube. **NOTE: Plastic NPT fittings are easy to cross thread. Install the vent fitting "hand" tight, then turn it two complete turns with a wrench.**



16. Install the AEM® intake tube into the Coupling hoses, adjust the tube for best fit and then secure with the provided hose clamps.



17. Connect the factory crank case vent line to the vent tube on the AEM® intake tube and secure the brake booster vacuum line to the intake tube as shown.



18. Connect the vacuum line to the AEM® intake tube and reconnect the mass air sensor electrical connection.



Reassemble Vehicle

Position the inlet pipes for the best fitment. Be sure that the pipes or any other components do not contact any part of the vehicle. Tighten the rubber mount, all bolts, and hose clamps. Check for proper hood clearance. Re-adjust pipes if necessary and re-tighten them. Inspect the engine bay for any loose tools and check that all fasteners that were moved or removed are properly tightened. Reconnect negative battery terminal and start engine. Let the vehicle idle for 3 minutes. Perform a final inspection before driving the vehicle.

Service and Maintenance

AEM Induction Systems requires cleaning the intake system's air filter element every 100,000 miles. When used in dusty or off-road environments, our filters will require cleaning more often. We recommend that you visually inspect your filter once every 25,000 miles to determine if the screen is still visible. When the screen is no longer visible some place on the filter element, it is time to clean it. To clean, purchase our Synthetic air filter cleaner, part number AEM-1-1000 and follow the easy instructions. Use window cleaner to clean your powder coated AEM® intake tube.

NOTE: DO NOT USE aluminum polish on powder coated AEM® intake tubes.

NOT LEGAL FOR SALE OR USE ON ANY POLLUTION CONTROLLED MOTOR VEHICLE IN CALIFORNIA OR STATES ADOPTING CALIFORNIA EMISSION PROCEDURES.

See aemintakes.com for CARB status on each part for a specific vehicle

AEM Air Intake System Warranty Policy

AEM® warrants that its intake systems will last for the life of your vehicle. AEM will not honor this warranty due to mechanical damage (i.e. improper installation or fitment), damage from misuse, accidents or flying debris. AEM will not warrant its powder coating if the finish has been cleaned with a hydrocarbon-based solvent. The powder coating should only be cleaned with a mild soap and water solution. Proof of purchase of both the vehicle and AEM intake system is required for redemption of a warranty claim.

This warranty is limited to the repair or replacement of the AEM part. In no event shall this warranty exceed the original purchase price of the AEM part nor shall AEM be responsible for special, incidental or consequential damages or cost incurred due to the failure of this product. Warranty claims to AEM must be transportation prepaid and accompanied with dated proof of purchase. This warranty applies only to the original purchaser of product and is nontransferable. Improper use or installation, use for racing, accident, abuse, unauthorized repairs or alterations voids this warranty. AEM disclaims any liability for consequential damages due to breach of any written or implied warranty on all products manufactured by AEM. Warranty returns will only be accepted by AEM when accompanied by a valid Return Merchandise Authorization (RMA) number. Credit for defective products will be issued pending inspection. Product must be received by AEM within 30 days of the date RMA is issued.

If you have a warranty issue, please call (800) 992-3000 and our customer service department will assist you. A proof of purchase is required for all AEM warranty claims.