



Equipped with AEM® Dryflow™ Filter
No Oil Required!

INSTALLATION INSTRUCTIONS

PART NUMBER

21-829C (GUN METAL GRAY FINISH)

2017

ACURA

RDX

3.5L

Not legal for sale or use on any pollution controlled motor vehicle in California or states adopting California emission procedures. See AEMIntakes.com for CARB status on each part for a specific vehicle.

ITEM NO.	PART NUMBER	DESCRIPTION	QTY.
1	21-210ED	ELEMENT PARTS KIT; DRY FLOW 6"B X 6"H	1
2	2-1603C	INTAKE TUBE; 3.50"OD X 6.25" L; 21-829, GUNMETAL GRAY	1
3	20-8605	HEAT SHIELD; 2017 ACURA RDX 3.5L	1
4	21512-1	ADAPTER; UNIVERSAL, 6" FILTER 3.5" COUPLER	1
5	08699	HOSE; 3-1/2" ID X 2-1/2" L HUMP REINFORCED	1
6	084093	HOSE; 3-1/2" TO 2-3/4" ID X 2" L TPRD REINFORCED	1
7	102461	EDGE TRIM; 3/4" BULB, TOP LOC, 80"	1
8	1228596	MOUNT, RUBBER M6 X 3/4" TALL M/F	1
9	07027	STUD; M6-1.00 M/M, RUBBER MNTD	1
10	8-168	ADAPTER, PCV	1
11	1-112	BOLT; BUTTON HEAD M6-1.0 X 10MM, SS	3
12	444.460.04	NUT; M6 HEX SERRATED	1
13	94104	1/2" BNDHOSE CLAMP,4.125-7.00"	1
14	9452	1/2" BNDHOSE CLAMP,2.90"-3.75"	3
15	9444	HOSE CLAMP, 2.31-3.25"	1

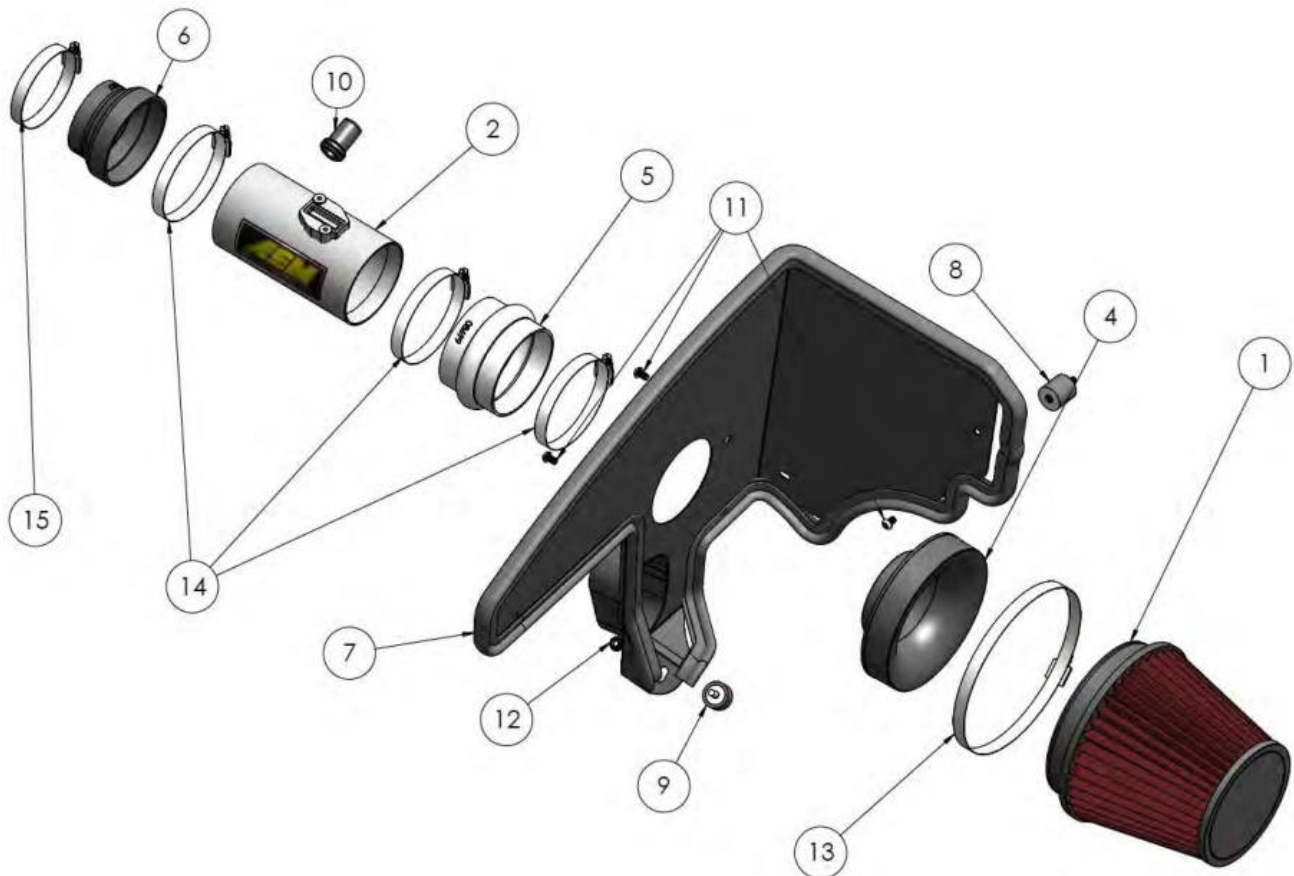

Read and understand these instructions **BEFORE** attempting to install this product. Failure to follow installation instructions and not using the provided hardware may damage the intake tube, throttle body and engine. If you need any assistance please call 1-800-858-3333 to speak with a representative in our Customer Service Center before returning the product.

1. Preparing Vehicle

- a. Make sure vehicle is parked on level surface.
- b. Set the parking brake.
- c. If engine has run in the past two hours, let it cool down.
- d. Disconnect negative battery terminal.
- e. Do not discard stock components after removal of the factory system.
- f. Open the air intake kit package and make sure all parts are included.

Tools Needed:	Optional:
Screwdrivers	Small Torque Wrench
10mm Socket	
Long Extension	
Socket Driver	
Side Cutters	
4mm Hex Key	

2. Removal of stock system



a. Remove the engine cover by pulling up gently. Use care not to lose the grommets in the engine cover as they tend to fall out easily.



b. Disconnect the Mass Air Flow (MAF) sensor harness from the sensor.



c. Remove the PCV tube and wire harness from the rubber intake hose.

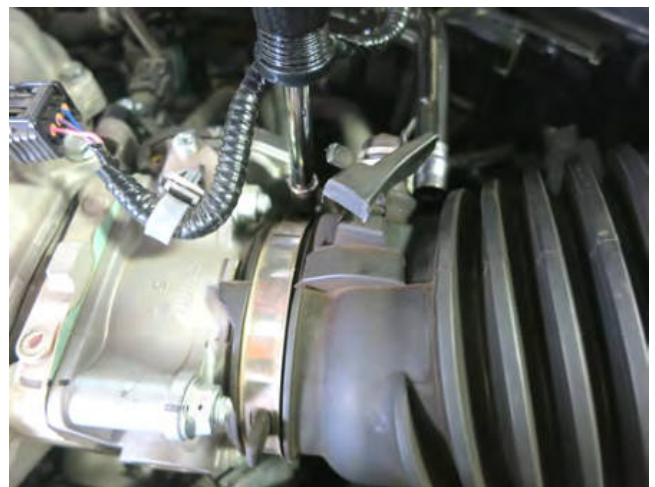

d. Loosen the hose clamp securing the hose to the throttle body.



e. Unlatch the air box lid clasps and lift the air box lid and intake air hose assembly out of the engine bay.

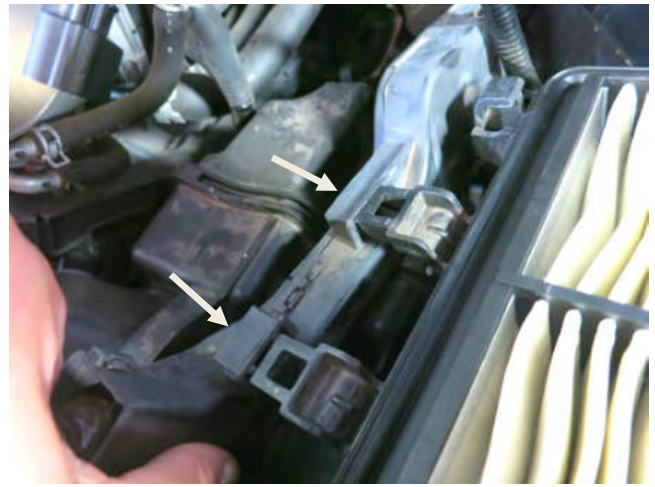

f. Disconnect the wiring harness from the air box base by depressing the clips.



g. Use an extension and 10mm socket to reach the lower air box bolt in the location shown.



h. Remove the fender shrouding by pulling up gently to reveal the upper air box bolt.



i. Remove the upper air box bolt.



j. Remove the bolt securing the air box to the shock tower.



k. Partially lift out the air box base to gain access to the MAF sensor harness tie and disconnect the harness.



l. Fully remove the air box base assembly. Be sure the rubber coupler stays attached to the factory air scoop. Reinstall it at this time if it removes with the air box assembly.



m. Remove the MAF sensor and screws from the air box lid. These will be reused in step 3a. **NOTE: Do not discard any of your stock equipment.**

3. Installation of AEM® intake system.

a. When installing the intake system, do not completely tighten the hose clamps or mounting hardware until instructed to do so.



a. Install the PCV grommet and the MAF sensor using the factory screws.



b. Install the tall rubber mount on to the shock tower bolt hole.



c. Install the shorter rubber mount on the lower air box bolt hole.



d. Using the step coupler and provided hose clamps, install the intake tube as shown. Connect the PCV tube at this time. Do not fully tighten the hose clamps at this time.



e. Install the edge trim as shown. Install the filter adapter using the provided hardware in the orientation shown.



f. Attach the straight coupler to the filter adapter. Only tighten the heatshield-side hose clamp at this time.



g. Lower the heat shield assembly into the engine bay and connect the intake tube to the filter adapter. Then, connect the factory air scoop to the heatshield.



h. Fasten the heatshield at the shock tower with the provided bolt.



i. Fasten the heatshield base to the lower rubber mount with the provided nut.



j. Install the AEM DryFlow air filter to the filter adapter with the provided hose clamp.

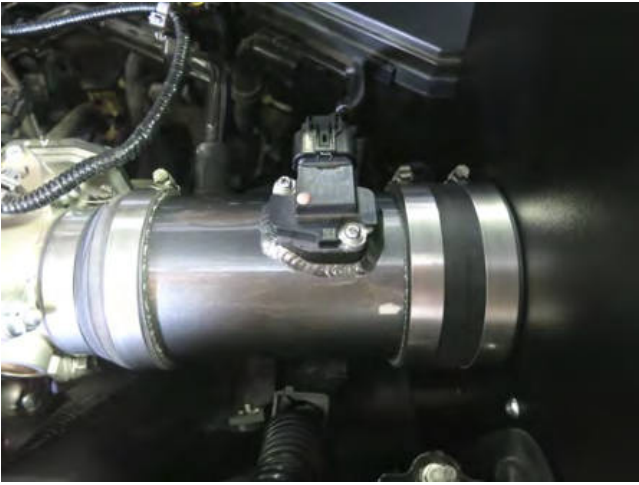

k. Connect the MAF sensor and tighten the hose clamps at this time.



l. Replace the upper fender shroud by rotating it into place and snapping it into in to the square holes.



m. Reinstall the engine cover by aligning the grommets with their posts and gently pushing down.



STOCK INTAKE INSTALLED



AEM INTAKE INSTALLED

4. Reassemble Vehicle

- a. Position all kit components for best fitment. Ensure that no components contact any unintended part of the vehicle.
- b. Check for proper hood clearance. Re-adjust components if necessary and re-tighten them.
- c. Inspect the engine bay for any loose tools and ensure that all fasteners that were moved or removed are properly tightened.
- d. Reconnect negative battery terminal and start engine. Let the vehicle idle for 3 minutes. Perform a final inspection before driving the vehicle.

5. Service and Maintenance

- a. AEM Induction Systems requires cleaning the intake system's air filter element every 100,000 miles. When used in dusty or off-road environments, our filters will require cleaning more often. We recommend that you visually inspect your filter once every 25,000 miles to determine if the screen is still visible. When the screen is no longer visible some place on the filter element, it is time to clean it. To clean, purchase our Synthetic air filter cleaner, part number 1-1000 and follow the easy instructions.
- b. Use window cleaner to clean your powder coated AEM[®] intake tube.

NOTE: DO NOT USE aluminum polish on powder coated AEM[®] intake tubes.

For technical inquiries
e-mail us at
sales@aemintakes.com
or
call us at
800.992.3000

AEM Air Intake System Warranty Policy

AEM® warrants that its intake systems will last for the life of your vehicle. AEM® will not honor this warranty due to mechanical damage (i.e. improper installation or fitment), damage from misuse, accidents or flying debris. AEM® will not warrant its powder coating if the finish has been cleaned with a hydrocarbon-based solvent. The powder coating should only be cleaned with a mild soap and water solution. Proof of purchase of both the vehicle and AEM® intake system is required for redemption of a warranty claim.

This warranty is limited to the repair or replacement of the AEM® part. In no event shall this warranty exceed the original purchase price of the AEM® part nor shall AEM® be responsible for special, incidental or consequential damages or cost incurred due to the failure of this product. Warranty claims to AEM® must be transportation prepaid and accompanied with dated proof of purchase. This warranty applies only to the original purchaser of product and is nontransferable. Improper use or installation, use for racing, accident, abuse, unauthorized repairs or alterations voids this warranty. AEM® disclaims any liability for consequential damages due to breach of any written or implied warranty on all products manufactured by AEM®. Warranty returns will only be accepted by AEM® when accompanied by a valid Return Merchandise Authorization (RMA) number. Credit for defective products will be issued pending inspection. Product must be received by AEM® within 30 days of the date RMA is issued.

If you have a warranty issue, please call (800) 992-3000 and our customer service department will assist you. A proof of purchase is required for all AEM® warranty claims.

Not legal for sale or use on any pollution controlled motor vehicle in California or states adopting California emission procedures. See AEMIntakes.com for CARB status on each part for a specific vehicle.