



INSTALLATION INSTRUCTIONS

21-846C (Gun Metal Gray Finish)
SUBARU
2017-21 Impreza
2018-21 Crosstrek
H4-2.0L

NOT LEGAL FOR SALE OR USE ON ANY POLLUTION CONTROLLED MOTOR VEHICLE IN CALIFORNIA OR STATES ADOPTING CALIFORNIA EMISSION PROCEDURES.

See aemintakes.com for CARB status on each part for a specific vehicle

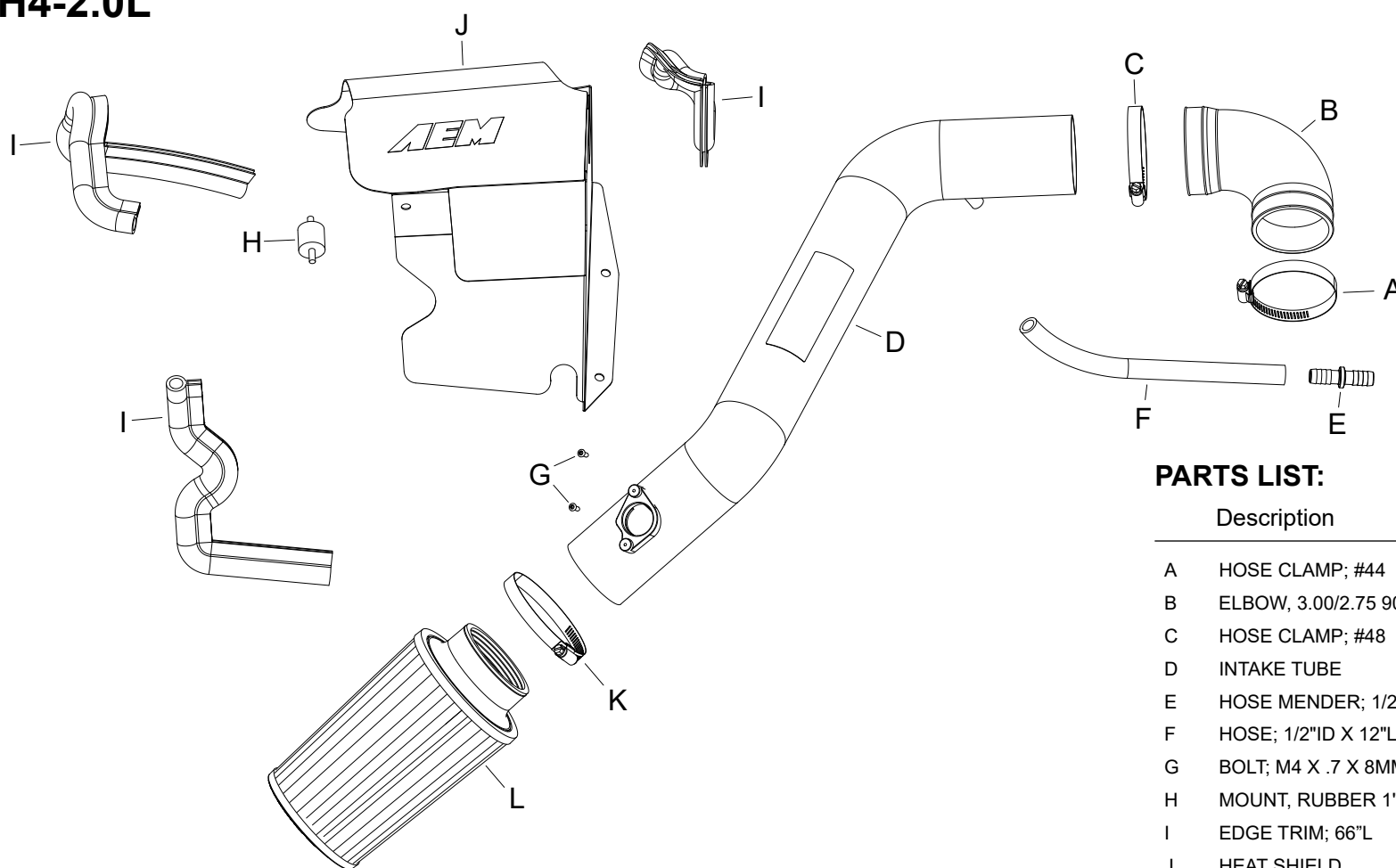

TOOLS NEEDED:

flat blade screw driver
 phillips screw driver
 ratchet
 extension
 10mm socket
 3mm allen key

PARTS LIST:

	Description	Qty.	Part #
A	HOSE CLAMP; #44	1	08577
B	ELBOW, 3.00/2.75 90 DEG	1	5-492
C	HOSE CLAMP; #48	1	08601
D	INTAKE TUBE	1	2-1617C
E	HOSE MENDER; 1/2" BARBED	1	08686
F	HOSE; 1/2"ID X 12"L	1	087031
G	BOLT; M4 X .7 X 8MM	2	07741
H	MOUNT, RUBBER 1" X 6MM	1	1228599
I	EDGE TRIM; 66"L	1	102472
J	HEAT SHIELD	1	20-8626
K	1/2" BNDHOSE CLAMP, 2.56"	1	9448
L	AIR FILTER; 3" X 8" DRYFLOW	1	21-2038DK

If you need any assistance please call 1-800-858-3333 to speak with a representative in our Customer Service Center before returning the product.

Read and understand these instructions **BEFORE** attempting to install this product. Failure to follow installation instructions and not using the provided hardware may damage the intake tube, throttle body and engine.

TO START:

1. Turn off the ignition and disconnect the negative battery cable.

NOTE: Disconnecting the negative battery cable erases pre-programmed electronic memories. Write down all memory settings before disconnecting the negative battery cable. Some radios will require an anti-theft code to be entered after the battery is reconnected. The anti-theft code is typically supplied with your owner's manual. In the event your vehicles anti-theft code cannot be recovered, contact an authorized dealership to obtain your vehicles anti-theft code.



2. Remove the two clips that secure the fresh air intake duct and then remove the duct from the vehicle.

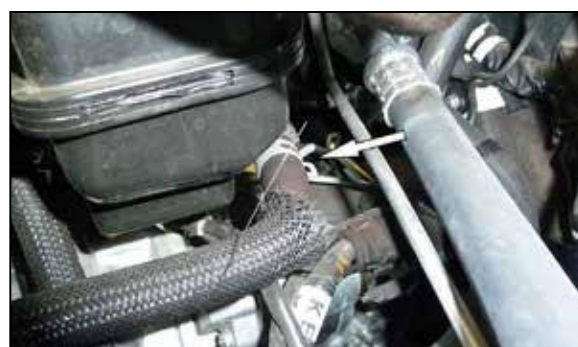

3. Release the spring clamp securing the vent hose to the intake plenum and then disconnect the hose from the plenum.



4. Remove the clip that secures the intake plenum to the manifold and then loosen the hose clamp that secures the intake tube to the throttle body.



5. Loosen the hose clamp securing the intake tube to the air filter housing and disconnect the mass air sensor electrical connection.



6. Release the air filter housing clips and remove the housing half and factory air filter. Remove the air filter housing retaining nut.
NOTE: This nut will be reused in a later step.



7. Remove the two bolts that secure the air filter housing to the frame rail, then remove the air filter housing.

NOTE: These bolts will be reused later.

NOTE: AEM recommends that customers do not discard factory air intake.



8. Remove the factory air filter housing mounting stud.

NOTE: The Mounting nut will be reused in a later step.

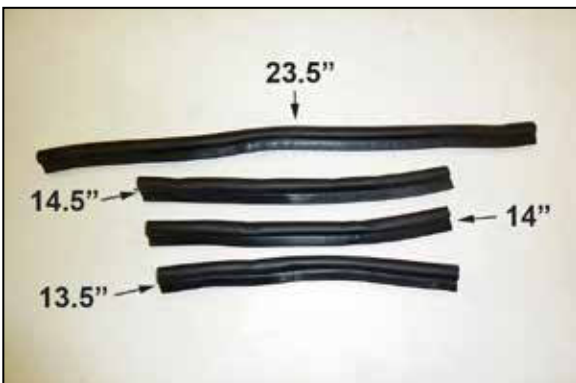

9. Cut the provided edge trim into four sections, 23.5", 14.5", 14" and 13.5".



10. Install the provided rubber mounted stud onto the heat shield using the factory nut.



11. Install the edge trim onto the heat shield as shown.



12. Install the AEM® intake tube through the heat shield, then remove the mass air sensor from the factory housing and install it into the AEM® intake tube using the provided hardware.



13. Install the AEM® air filter onto the intake tube and secure with the provided hose clamp.



14. Install the provided 90° coupler onto the throttle body but do not completely tighten the hose clamp at this time.



15. Position the mass air sensor wiring pigtail along the frame as shown.



16. Install the intake assembly so the intake tube goes into the coupler at the throttle body and the heat shield rests on the frame and the mounting holes line up correctly.



17. Secure the heat shield to the frame with the factory air filter housing mounting bolts.



18. Using the factory nut, secure the rubber mounted stud to the core support.



19. Reaching in through the fresh air opening in the heat shield, retrieve the mass air sensor wiring pigtail laying on the frame and connect it to the mass air sensor. Check to make sure that the wire is not pinched or bound with could cause damage to the wiring.



20. Align the intake tube for best fit and then secure the coupler hose clamps.



21. Install the provided hose union into the provided crank case vent hose as shown.



22. Install the crank case vent hose assembly into the factory crank case vent hose and secure with the factory spring clamp.



23. Connect the open end of the crank case vent hose to the fitting on the AEM® intake tube.



24. Reinstall the factory fresh air intake duct and secure with the factory hardware.



Reassemble Vehicle

Position the inlet pipes for the best fitment. Be sure that the pipes or any other components do not contact any part of the vehicle. Tighten the rubber mount, all bolts, and hose clamps. Check for proper hood clearance. Re-adjust pipes if necessary and re-tighten them. Inspect the engine bay for any loose tools and check that all fasteners that were moved or removed are properly tightened. Reconnect negative battery terminal and start engine. Let the vehicle idle for 3 minutes. Perform a final inspection before driving the vehicle.

Service and Maintenance

AEM Induction Systems requires cleaning the intake system's air filter element every 100,000 miles. When used in dusty or off-road environments, our filters will require cleaning more often. We recommend that you visually inspect your filter once every 25,000 miles to determine if the screen is still visible. When the screen is no longer visible some place on the filter element, it is time to clean it. To clean, purchase our Synthetic air filter cleaner, part number AEM-1-1000 and follow the easy instructions. Use window cleaner to clean your powder coated AEM® intake tube.

NOTE: DO NOT USE aluminum polish on powder coated AEM® intake tubes.

NOT LEGAL FOR SALE OR USE ON ANY POLLUTION CONTROLLED MOTOR VEHICLE IN CALIFORNIA OR STATES ADOPTING CALIFORNIA EMISSION PROCEDURES.

See aemintakes.com for CARB status on each part for a specific vehicle

AEM Air Intake System Warranty Policy

AEM® warrants that its intake systems will last for the life of your vehicle. AEM will not honor this warranty due to mechanical damage (i.e. improper installation or fitment), damage from misuse, accidents or flying debris. AEM will not warrant its powder coating if the finish has been cleaned with a hydrocarbon-based solvent. The powder coating should only be cleaned with a mild soap and water solution. Proof of purchase of both the vehicle and AEM intake system is required for redemption of a warranty claim.

This warranty is limited to the repair or replacement of the AEM part. In no event shall this warranty exceed the original purchase price of the AEM part nor shall AEM be responsible for special, incidental or consequential damages or cost incurred due to the failure of this product. Warranty claims to AEM must be transportation prepaid and accompanied with dated proof of purchase. This warranty applies only to the original purchaser of product and is nontransferable. Improper use or installation, use for racing, accident, abuse, unauthorized repairs or alterations voids this warranty. AEM disclaims any liability for consequential damages due to breach of any written or implied warranty on all products manufactured by AEM. Warranty returns will only be accepted by AEM when accompanied by a valid Return Merchandise Authorization (RMA) number. Credit for defective products will be issued pending inspection. Product must be received by AEM within 30 days of the date RMA is issued.

If you have a warranty issue, please call (800) 992-3000 and our customer service department will assist you. A proof of purchase is required for all AEM warranty claims.