



INTAKE SYSTEM

INSTALLATION INSTRUCTIONS

21-870C

TOYOTA

2007-11 Camry

2009-15 Venza

V6-3.5L

NOT LEGAL FOR SALE OR USE ON ANY POLLUTION CONTROLLED MOTOR VEHICLE IN CALIFORNIA OR STATES ADOPTING CALIFORNIA EMISSION PROCEDURES.

See aemintakes.com for CARB status on each part for a specific vehicle

TOOLS NEEDED:

Flat blade screw driver
Phillips screw driver
ratchet
Extension
10mm socket
Pliers
10mm wrench
4mm allen key
3mm allen key
3/4" wrench
9/16" wrench

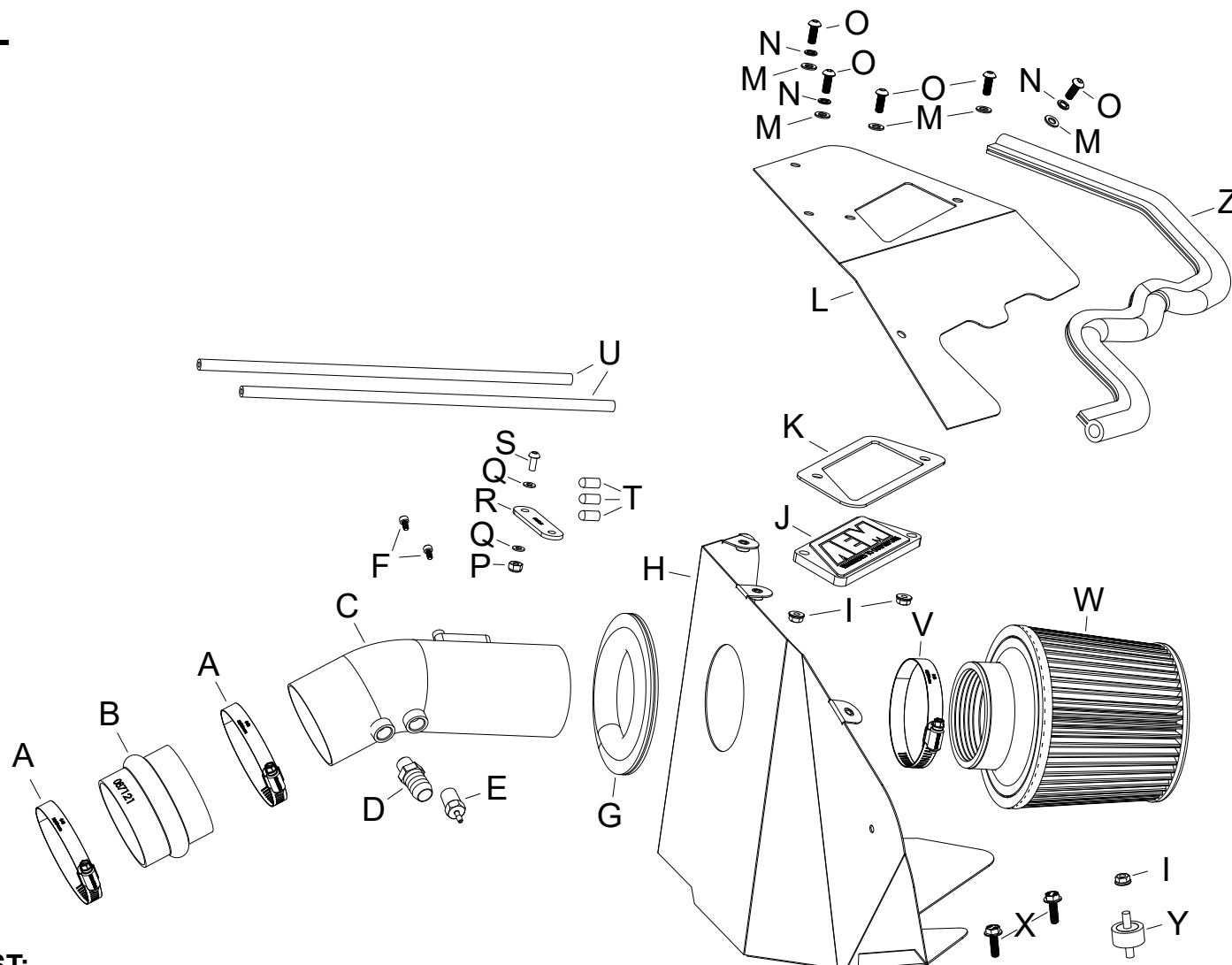

PARTS LIST:

Description	Qty.	Part #	Description	Qty.	Part #	Description	Qty.	Part #
A HOSE CLAMP #48	2	08601	J PLATE; AEM LOGO, CLEAR	1	8-211-1	S BOLT; M5 X .8 X 12MM	1	07734
B HOSE; HUMP 3"ID X 2.5"L	1	087121	K SPACER; ALUM CLEAR BADGE	1	7-364	T CAP; RUBBER 5/16"OD X 5/3"	3	08282
C TUBE; AL, GUNMETAL	1	25825C	L LID	1	073295	U HOSE; 1/8" SAE J30R7	2	KITHOSE48
D FITTING; VENT, 1/4" NPT, 5/8"	1	82638	M WASHER; 6MM FLAT	5	08269	V 1/2" BNDHOSE CLAMP, 2.90"	1	9452
E VENT; 1/8 HOSE, 1/4 NPT	1	08052	N WASHER, M6 SPLIT LOCK ZINC	3	1-3025	W AIR FILTER	1	21-203DK
F BOLT; M4 - .7 X 8MM	2	07733	O BOLT; M6 X 1 X 16MM	5	07730	X BOLT; M6-1 X 12	2	1-2110
G EDGE TRIM; 11"L	1	102468	P NUT; M5 X 0.8, NYLOCK	1	07507	Y STUD; M6-1.00 M/M, RUBBER	1	07027
H HEAT SHIELD	1	073292	Q WASHER; 5MM FLAT	2	08212	Z EDGE TRIM; 26"L	1	102488
I NUT; M6, HEX, SERRATED	3	444.460.04	R BRACKET; "STRT"	1	083166			

If you need any assistance please call 1-800-858-3333 to speak with a representative in our Customer Service Center before returning the product.

Read and understand these instructions **BEFORE** attempting to install this product. Failure to follow installation instructions and not using the provided hardware may damage the intake tube, throttle body and engine.

TO START:

1. Turn off the ignition and disconnect the negative battery cable.

NOTE: Disconnecting the negative battery cable erases pre-programmed electronic memories. Write down all memory settings before disconnecting the negative battery cable. Some radios will require an anti-theft code to be entered after the battery is reconnected. The anti-theft code is typically supplied with your owner's manual. In the event your vehicles anti-theft code cannot be recovered, contact an authorized dealership to obtain your vehicles anti-theft code.



2. Lift off and remove the decorative engine cover.



3. Disconnect the mass air sensor electrical connection.



4. Disconnect the vacuum hose from the intake plenum.



5. Disconnect the vacuum hose from the upper air filter housing and the other hose from the union shown.



6. Disconnect the vacuum lines from the vacuum switch and the "TEE" fitting shown.



7. Remove the vacuum switch and set aside for later use.



8. Release the spring clamp and disconnect the crank case vent line. Loosen the hose clamp that secures the intake hose to the throttle body. Release the three clips securing the upper air filter housing and then remove the housing and intake hose from the vehicle.



9. Remove the three bolts that secure the lower air filter housing and then remove the housing from the vehicle.

NOTE: AEM recommends that customers do not discard factory air intake.



10. Install the rubber mounted stud onto the filter housing bracket where shown.



11. Install the provided edge trim onto the heat shield and lid as shown.



12. Install the AEM® window into the heat shield lid using the provided hardware.



13. Install the heat shield onto the filter housing bracket and secure with the provided hardware.



14. Install the provided coupler (087121) onto the throttle body and secure with the provided hose clamp.



15. Install the provided vent fittings into the AEM® intake tube as shown.

NOTE: NPT fitting has tapered threads and only designed to be installed until hand tight, then tighten one rotation or when the fitting becomes difficult to return.



16. Remove the mass air sensor from the factory housing and install it into the AEM® intake tube and secure with the provided hardware.



17. Install the AEM® intake tube through the heat shield and into the coupler at the throttle body and secure with the provided hose clamp. Connect the crank case vent line and secure with the factory spring clamp.



18. Using the provided bracket (083166) secure the vacuum switch to the valve cover and reconnect the electrical connector.



19. Install two of the provided vacuum plugs onto the vacuum switch as shown. Install the remaining vacuum plug onto the factory "TEE" fitting as shown.

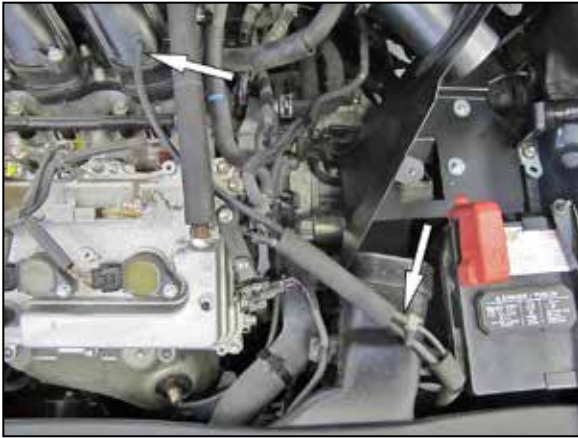

20. Install the provided vacuum line onto the factory "TEE" fitting and then connect the other end to the intake plenum.



21. Connect the provided vacuum line to the open factory vacuum line and then to the AEM® intake tube.



22. Install the AEM® air filter onto the intake tube and secure with the provided hose clamp.



23. Install the heat shield lid and secure with the provided hardware.



24. Reconnect the mass air sensor electrical connection.



Reassemble Vehicle

Position the inlet pipes for the best fitment. Be sure that the pipes or any other components do not contact any part of the vehicle. Tighten the rubber mount, all bolts, and hose clamps. Check for proper hood clearance. Re-adjust pipes if necessary and re-tighten them. Inspect the engine bay for any loose tools and check that all fasteners that were moved or removed are properly tightened. Reconnect negative battery terminal and start engine. Let the vehicle idle for 3 minutes. Perform a final inspection before driving the vehicle.

Service and Maintenance

AEM Induction Systems requires cleaning the intake system's air filter element every 100,000 miles. When used in dusty or off-road environments, our filters will require cleaning more often. We recommend that you visually inspect your filter once every 25,000 miles to determine if the screen is still visible. When the screen is no longer visible some place on the filter element, it is time to clean it. To clean, purchase our Synthetic air filter cleaner, part number 99-0624 and follow the easy instructions. Use window cleaner to clean your powder coated AEM® intake tube.

NOTE: DO NOT USE aluminum polish on powder coated AEM® intake tubes.

NOT LEGAL FOR SALE OR USE ON ANY POLLUTION CONTROLLED MOTOR VEHICLE IN CALIFORNIA OR STATES ADOPTING CALIFORNIA EMISSION PROCEDURES.

See aemintakes.com for CARB status on each part for a specific vehicle

AEM Air Intake System Warranty Policy

AEM® warrants that its intake systems will last for the life of your vehicle. AEM will not honor this warranty due to mechanical damage (i.e. improper installation or fitment), damage from misuse, accidents or flying debris. AEM will not warrant its powder coating if the finish has been cleaned with a hydrocarbon-based solvent. The powder coating should only be cleaned with a mild soap and water solution. Proof of purchase of both the vehicle and AEM intake system is required for redemption of a warranty claim.

This warranty is limited to the repair or replacement of the AEM part. In no event shall this warranty exceed the original purchase price of the AEM part nor shall AEM be responsible for special, incidental or consequential damages or cost incurred due to the failure of this product. Warranty claims to AEM must be transportation prepaid and accompanied with dated proof of purchase. This warranty applies only to the original purchaser of product and is nontransferable. Improper use or installation, use for racing, accident, abuse, unauthorized repairs or alterations voids this warranty. AEM disclaims any liability for consequential damages due to breach of any written or implied warranty on all products manufactured by AEM. Warranty returns will only be accepted by AEM when accompanied by a valid Return Merchandise Authorization (RMA) number. Credit for defective products will be issued pending inspection. Product must be received by AEM within 30 days of the date RMA is issued.

If you have a warranty issue, please call (800) 992-3000 and our customer service department will assist you. A proof of purchase is required for all AEM warranty claims.