



INTAKE SYSTEM

INSTALLATION INSTRUCTIONS

21-873C
HYUNDAI
2019-22 Veloster N
L4-2.0L Turbo

NOT LEGAL FOR SALE OR USE ON ANY POLLUTION CONTROLLED MOTOR VEHICLE IN CALIFORNIA OR STATES ADOPTING CALIFORNIA EMISSION PROCEDURES.

See aemintakes.com for CARB status on each part for a specific vehicle

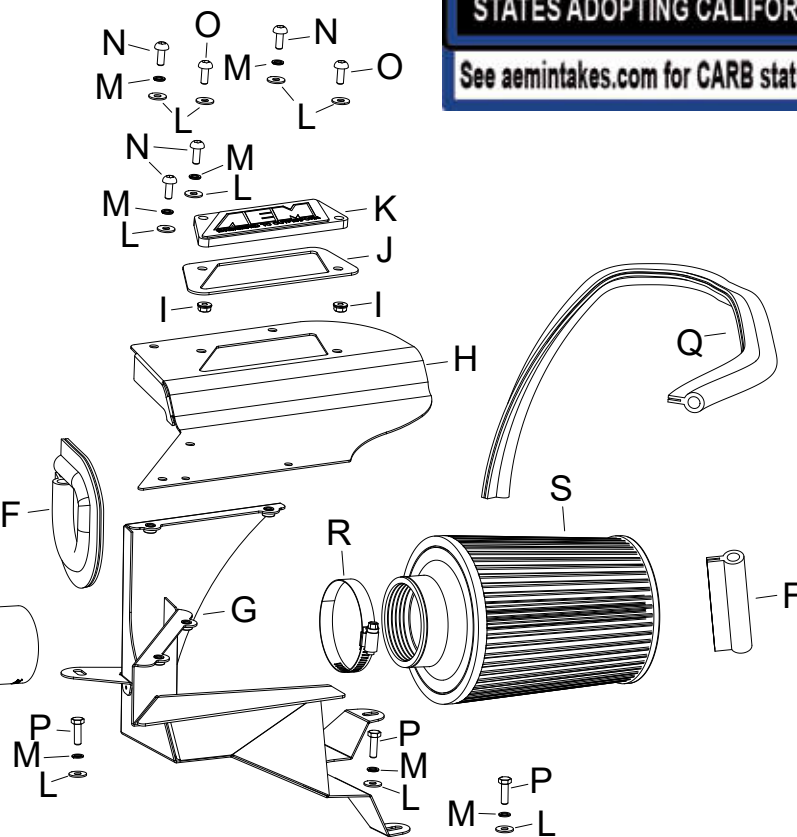

TOOLS NEEDED:

Ratchet
 Extension
 universal
 5/16" socket
 10mm socket
 4mm allen key
 9/16" wrench
 Flat blade screw driver

PARTS LIST:

Description	Qty.	Part #	Description	Qty.	Part #	Description	Qty.	Part #
A HOSE CLAMP #40	1	08554	H HEAT SHIELD LID	1	073299	O BOLT; M6 X 1.00 X 16MM, SS	2	07730
B HOSE; HUMP 2.5"/2.75" X 3"	1	5-1067	I NUT; M6, HEX, SERRATED	2	444.460.04	P BOLT; 6MM-1.00 X 16MM, SS	3	07812
C HOSE CLAMP #44 STAINLESS	1	08560	J SPACER; ALUM, AEM-8-211	1	7-364	Q EDGE TRIM (20")	1	102494A
D FITTING; VENT 1/4NPT, 90DEG.	1	08523	K PLATE; AEM LOGO, CLEAR	1	8-211	R 1/2" BNDHOSE CLAMP, 2.56"	1	9448
E INTAKE TUBE	1	25830C	L WASHER; 6MM FLAT, SS	9	08269	S FILTER	1	21-2027DK
F EDGE TRIM (35")	1	102471A	M WASHER, M6 SPLIT LOCK ZINC	7	1-3025			
G HEAT SHIELD	1	073298	N BOLT; M6 X 1.00" 12MM, SS	4	07794			

If you need any assistance please call 1-800-858-3333 to speak with a representative in our Customer Service Center before returning the product.

Read and understand these instructions **BEFORE** attempting to install this product. Failure to follow installation instructions and not using the provided hardware may damage the intake tube, throttle body and engine.

TO START:

1. Turn off the ignition and disconnect the negative battery cable.

NOTE: Disconnecting the negative battery cable erases pre-programmed electronic memories. Write down all memory settings before disconnecting the negative battery cable. Some radios will require an anti-theft code to be entered after the battery is reconnected. The anti-theft code is typically supplied with your owner's manual. In the event your vehicles anti-theft code cannot be recovered, contact an authorized dealership to obtain your vehicles anti-theft code.



2. Release the spring clamps and then disconnect the vent lines and BOV hose.



3. Loosen the hose clamps that secure the factory intake tube and then remove the intake tube from the vehicle.



4. Remove the two push pins that secure the fresh air intake duct. Remove the three bolts that secure the factory air filter housing and then remove the housing from the vehicle.

NOTE: AEM recommends that customers do not discard factory air intake.



5. Cut the provided edge trim into sections of 6", 10-1/2", 14" from the 35" and then install it onto the heat shield as shown.



6. Install the heat shield into the vehicle and secure with the provided hardware.



7. Install the provided coupler (5-1067) onto the turbo inlet and secure with the provided hose clamp.



8. Install the 90° vent fitting onto the AEM® intake tube as shown.

NOTE: Plastic NPT fittings are easy to cross thread. Install the vent fitting “hand” tight, then turn it two complete turns with a wrench.



9. Install the intake tube into the coupler at the turbo and secure with the provided hose clamp.



10. Install the vent lines and BOV hose onto the AEM® intake tube and secure with the factory spring clamps.



11. Cut the remaining edge trim into lengths of 3" and 14-1/2" and then install onto the heat shield lid as shown.



12. Install the AEM® window into the heat shield lid with the spacer between the lid and window and secure with the provided hardware.



13. Install the AEM® air filter onto the intake tube and secure with the provided hose clamp.



14. Install the heat shield lid and secure with the provided hardware.



Reassemble Vehicle

Position the inlet pipes for the best fitment. Be sure that the pipes or any other components do not contact any part of the vehicle. Tighten the rubber mount, all bolts, and hose clamps. Check for proper hood clearance. Re-adjust pipes if necessary and re-tighten them. Inspect the engine bay for any loose tools and check that all fasteners that were moved or removed are properly tightened. Reconnect negative battery terminal and start engine. Let the vehicle idle for 3 minutes. Perform a final inspection before driving the vehicle.

Service and Maintenance

AEM Induction Systems requires cleaning the intake system's air filter element every 100,000 miles. When used in dusty or off-road environments, our filters will require cleaning more often. We recommend that you visually inspect your filter once every 25,000 miles to determine if the screen is still visible. When the screen is no longer visible some place on the filter element, it is time to clean it. To clean, purchase our Synthetic air filter cleaner, part number AEM-1-1000 and follow the easy instructions. Use window cleaner to clean your powder coated AEM® intake tube.

NOTE: DO NOT USE aluminum polish on powder coated AEM® intake tubes.

NOT LEGAL FOR SALE OR USE ON ANY POLLUTION CONTROLLED MOTOR VEHICLE IN CALIFORNIA OR STATES ADOPTING CALIFORNIA EMISSION PROCEDURES.

See aemintakes.com for CARB status on each part for a specific vehicle

AEM Air Intake System Warranty Policy

AEM® warrants that its intake systems will last for the life of your vehicle. AEM will not honor this warranty due to mechanical damage (i.e. improper installation or fitment), damage from misuse, accidents or flying debris. AEM will not warrant its powder coating if the finish has been cleaned with a hydrocarbon-based solvent. The powder coating should only be cleaned with a mild soap and water solution. Proof of purchase of both the vehicle and AEM intake system is required for redemption of a warranty claim.

This warranty is limited to the repair or replacement of the AEM part. In no event shall this warranty exceed the original purchase price of the AEM part nor shall AEM be responsible for special, incidental or consequential damages or cost incurred due to the failure of this product. Warranty claims to AEM must be transportation prepaid and accompanied with dated proof of purchase. This warranty applies only to the original purchaser of product and is nontransferable. Improper use or installation, use for racing, accident, abuse, unauthorized repairs or alterations voids this warranty. AEM disclaims any liability for consequential damages due to breach of any written or implied warranty on all products manufactured by AEM. Warranty returns will only be accepted by AEM when accompanied by a valid Return Merchandise Authorization (RMA) number. Credit for defective products will be issued pending inspection. Product must be received by AEM within 30 days of the date RMA is issued.

If you have a warranty issue, please call (800) 992-3000 and our customer service department will assist you. A proof of purchase is required for all AEM warranty claims.