



Installation Instructions
Part Number 200-512-1
99-06 GM Trucks and SUVs
2007 GM "Classic" Trucks
4.8L, 5.3L, 6.0L, & 8.1L
04 Pontiac GTO 5.7L

Parts List

AIR-KIT512-1PA Aluminum Plate	(1)
AIR-KIT512-1G Gasket	(1)
AIR-KIT512-1H Hardware	
6mmx45mm Bolts	(3)
6mm Flat Washers	(3)
Fiber Gasket	(1)
1/2" Extension Plate	(3)
6mm Flat Head Screw	(3)

Tools Required For Installation

5/16", 4mm, & 10mm Sockets
5/32" Allen Wrench
Ratchet and Extension

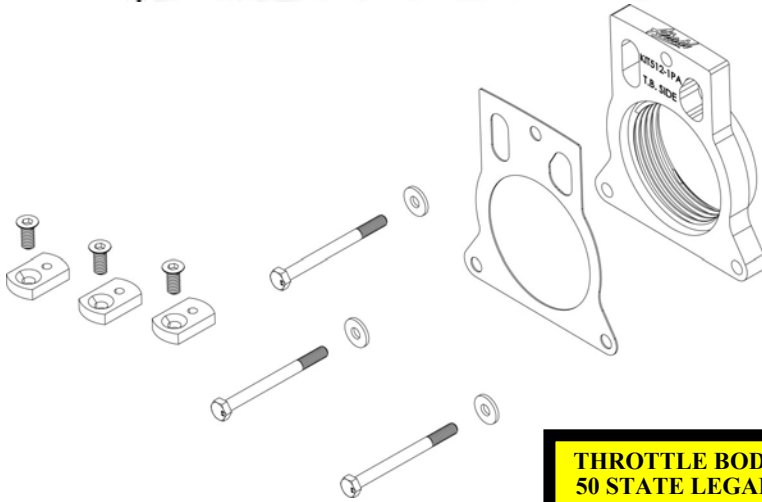

**THROTTLE BODY SPACER FOR VEHICLES LISTED ARE
50 STATE LEGAL. SEE AIRAID.COM FOR CARB STATUS
ON EACH PART FOR A SPECIFIC VEHICLE.**

Thank you for purchasing the Airaid Throttle Body Spacer. Please read the instruction manual carefully before proceeding with the installation. Your Airaid Throttle Body Spacer was carefully inspected and packaged. Check that no parts are missing, or were damaged during shipping. If you need any assistance please call 1-800-858-3333 to speak with a representative in our Customer Service Center before returning the product.
Thank you for selecting AIRAID.



1. **Disconnect the negative battery cable!** Loosen one bolt and remove the beauty cover. Pry the tube from the clamp on the radiator hose. Loosen the hose clamps on each end of the intake tube and remove the tube.

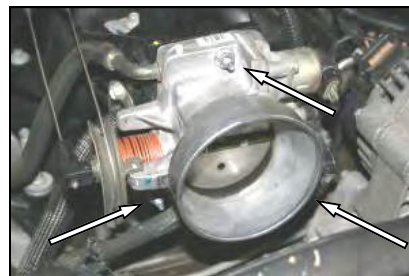

2. Using a 10mm socket, remove the three nuts that hold the throttle body to the intake manifold.



3. Using a 4mm socket, remove the three studs that hold the throttle body to the intake manifold. No need to remove the throttle body, leave it hang where it is.

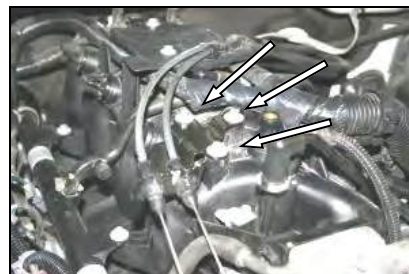

4. **If you have an electronic throttlebody, (no cables) skip to step #6.** Using a 5/16" socket, remove and save 3 bolts that hold the throttle cable bracket to the intake manifold. **(Disregard steps #4, #5, and #8, if you are working on a 8.1L).**



5. Install three 1/2" extension plates (#5) using the provided flat head countersunk bolts(#6). Point the long end towards the radiator, and snug them down.

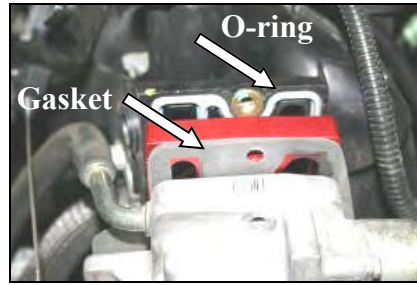

6. Place one fiber gasket (#4) between the Airaid spacer (#1) and the throttle body. Make sure the flat face of the Airaid spacer is against the throttle body with the bore extending into the intake manifold. **Use caution to retain the factory o-ring gasket on the intake manifold.**

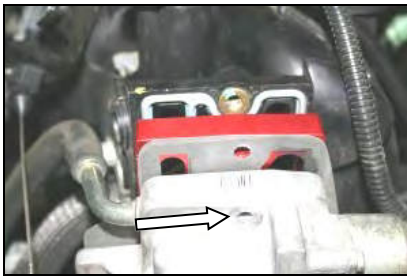

7. Install the top bolt (#2) and washer (#3) first, run it in a few threads with your fingers, leave it loose, and then align the two bottom holes and install the bolts and washers. Use caution not to cross thread the bolts. **Do Not Over Tighten The Bolts!**

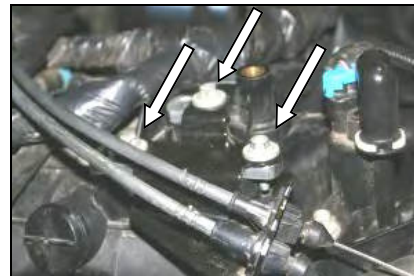

8. **If you have an electronic throttlebody, (no cables) skip to step #10.** Re-install the throttle cable bracket and the 3 factory bolts removed in step 4. Some minor adjustments to the extension plates may be necessary to get all three bolts to be aligned in position.

9. Inspect & test the throttle linkage for full open and closed travel before driving. Some cruise and kickdown cables may require adjustment. Please refer to vehicles service manual for proper adjustment.



10. Re-install the intake tube and tighten the hose clamps. Re-install the plastic holder from step #1. Re-install the beauty cover and bolt. **Re-connect the negative battery cable!**

The sound of power...The "whistle" means its working!

AIR-I20512-1C
Rev. 07.31.20