



200-550 INSTALLATION INSTRUCTIONS 91-95 C/K 7.4L

Thank you for purchasing the Airaid Throttle Body Spacer. Please read the instruction manual carefully before proceeding with the installation. Your Airaid Throttle Body Spacer was carefully inspected and packaged. Check that no parts are missing, or were damaged during shipping. If you need any assistance please call 1-800-858-3333 to speak with a representative in our Customer Service Center before returning the product.

Thank you for selecting AIRAID.

**THROTTLE BODY SPACERS FOR VEHICLES LISTED ARE
50 STATE LEGAL. SEE AIRAID.COM FOR CARB STATUS ON
EACH PART FOR A SPECIFIC VEHICLE.**

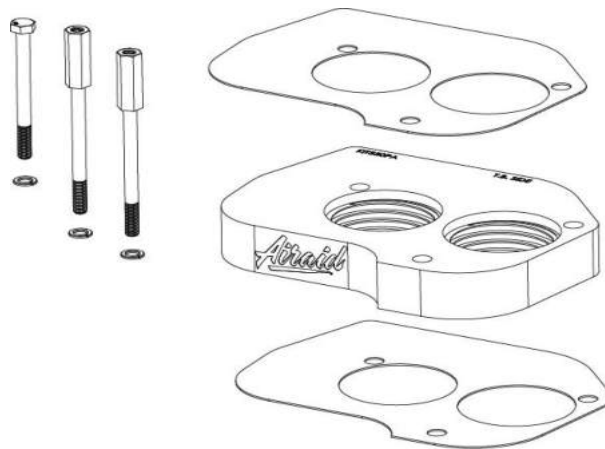

Ask about our Airaid Intake System for your vehicle. Call for details!

Parts List

AIR-KIT550PA	Aluminum Plate	(1)
AIR-KIT550G	Gasket	(2)
AIR-KIT550H	Hardware	
	Drilled & Tapped Bolts	(2)
	Hex Bolt	(1)
	8mm Flat Washers	(3)

Tools List

1/2" Socket
Standard Screwdriver

Installation Instructions. Read Me!

1. **DISCONNECT NEGATIVE (-) BATTERY CABLE.**
2. Remove air cleaner.
3. Using 1/2" socket, remove (3) 5/16" bolts.
* **Please Note: Some units have bolts that are drilled and tapped for air cleaner mounting studs.**
4. It is not necessary to remove the fuel lines.
5. Remove fuel line bracket from transmission. (Located on drivers side of bell housing)
6. Lift throttle body unit.
7. Remove gasket and clean surfaces.
8. Install spacer using (2) gaskets.
 - A. Locate first gasket between TBI unit and spacer.
 - B. Locate second gasket between spacer and manifold.
9. Install power plate using (2) drilled and tapped bolts, (1) hex bolt, and three 8mm flat washers. Refer to Step 3
10. Replace air cleaner studs if applicable.
11. Inspect & Test throttle linkage for full Open & Closed travel before driving. Some cruise or kickdown cables may require adjustment. Please refer to your vehicles service manual for proper adjusting.
12. Reinstall the air cleaner.
13. Reinstall fuel line bracket. Refer to Step 5
14. Reconnect battery cable. Enjoy!

The sound of power...the "whistle" means it's working!

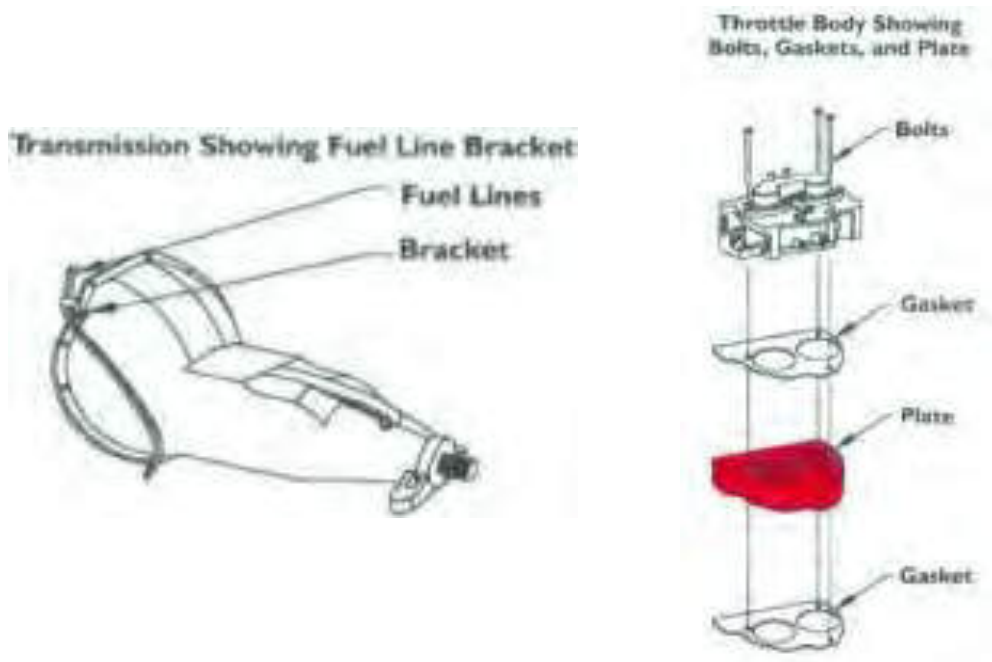

AIR-I20550C
Rev. 09-15-20