

Airaid

Installation Instructions
For Part Numbers:

200-985 Modular Intake Tube

CHEVROLET / GMC
2014-18 Silverado 1500 / Sierra 1500
2019 Silverado LD 1500 / Sierra Limited 1500
2015-20 Tahoe / Suburban
2015-20 Yukon / Yukon XL
5.3L V8

NOT LEGAL FOR SALE OR USE ON ANY POLLUTION CONTROLLED MOTOR VEHICLE IN CALIFORNIA OR STATES ADOPTING CALIFORNIA EMISSION PROCEDURES.

See AIRAID.COM for CARB status on each part for a specific vehicle.

Component Identification

#1 AIR-KIT985T	Airaid Intake Tube	1
#2 AIR-KITHUMPHS18EPDM	Hump Hose	1
#3 AIR-KITRDCR18	Reducing Coupler	1
#4 08620	#56 Hose Clamp	1
#5 AIR-KITHS64	#64 Hose Clamp	3
#6 AIR-KITSNP19M4	Speed Clamp	4
#7 AIR-KITFITTING16	Barbed Fitting	1
#8 AIR-KITFITTING33	Quick Connector	2
#9 AIR-KITFITTING36	Barbed Elbow Fitting	1
#10 AIR-KITHOSE14	10-1/2" Breather Hose	1
#11 AIR-KITHOSE20	23-1/2" Breather Hose	1

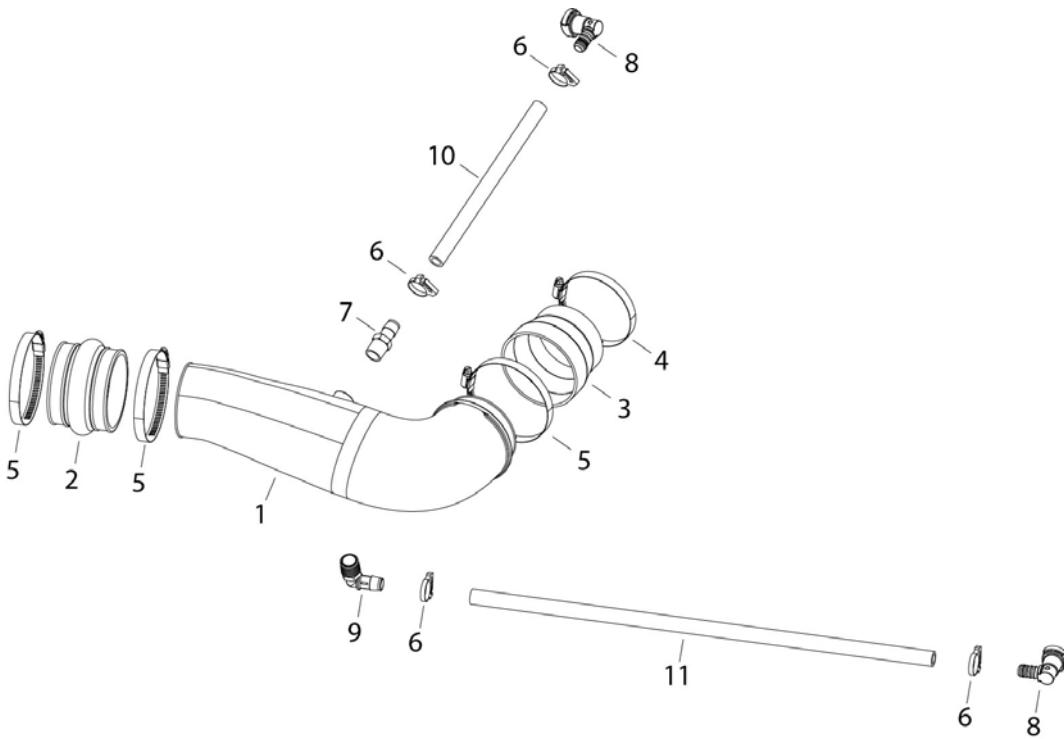

Full color instructions can be viewed on our web site at Airaid.com. Use the **Product Search** function to find your part number, and click **View Details**. If you need any assistance please call 1-800-858-3333 to speak with a representative in our Customer Service Center before returning the product.

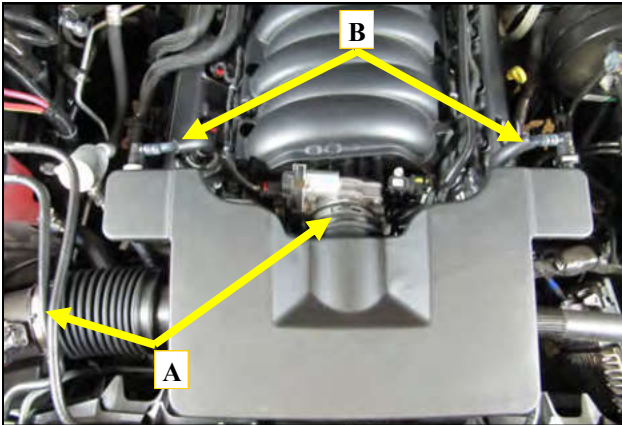

1. Disconnect The Negative Battery Terminal!
A.) loosen the clamps securing the intake system to the throttle body and the air box.
B.) Disconnect the valve cover breathers from either side of the factory intake System. Remove the factory intake system and set it aside.



2. The quick connects for the valve cover breathers are removed by depressing the grey locking tab in the fitting and sliding them off.



3. Install the Barbed Fitting into the Intake Tube as shown.



4. Install the 90 deg. Barbed fitting into the Intake Tube exactly as shown.

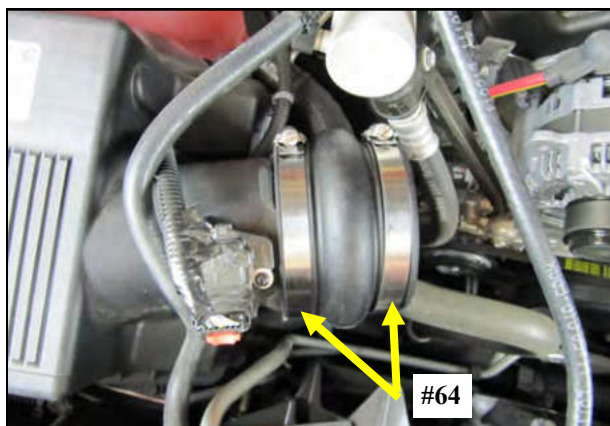

5. Slide the Hump Hose and two #64 Clamps onto the factory air box.



6. Slide the Reducer and the #56 and 64 clamps onto the throttle body.

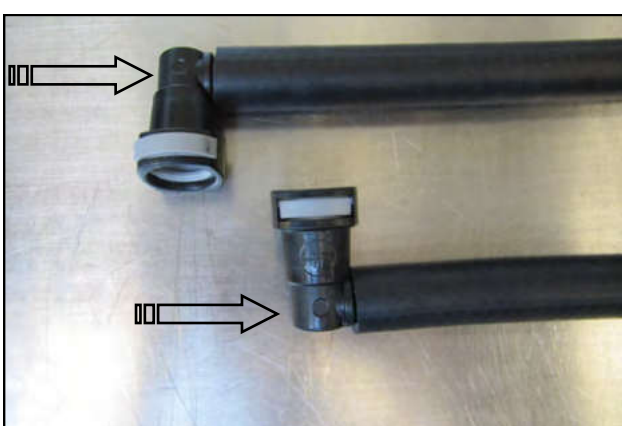

7. Insert the new Quick Connect Fittings into the supplied Breather Hoses.

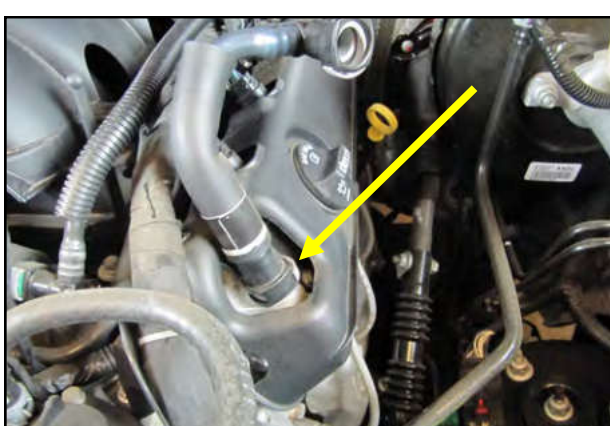

8. Remove the valve cover breathers from both sides of the motor and set them aside. They will not be reused.

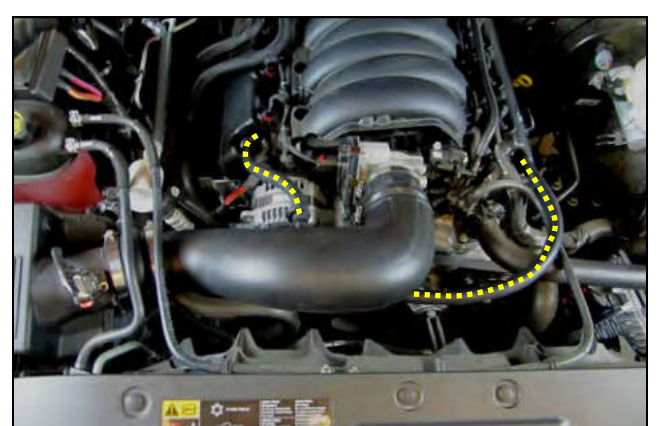

9. Install the Intake Tube and tighten the Clamps. Connect the new breathers to the Barbed Fittings in the Intake tube and the Quick Connect Fittings to the Valve covers .

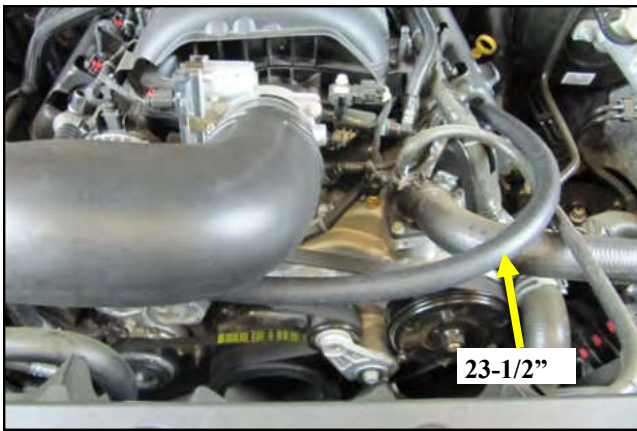

10. The 23-1/2" Hose is to be on the Drivers side. As shown.

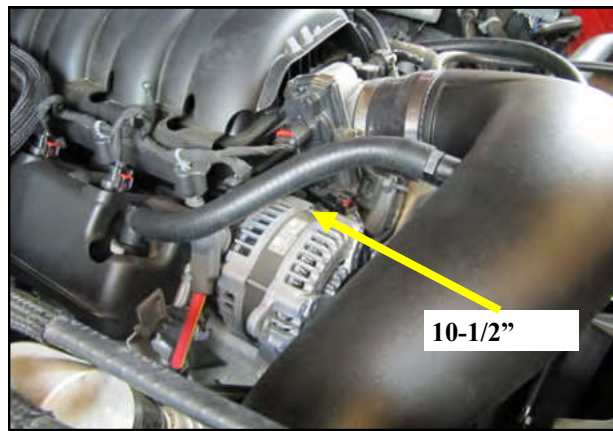

11. The 10-1/2" Hose is to be used on the Passenger side as shown.

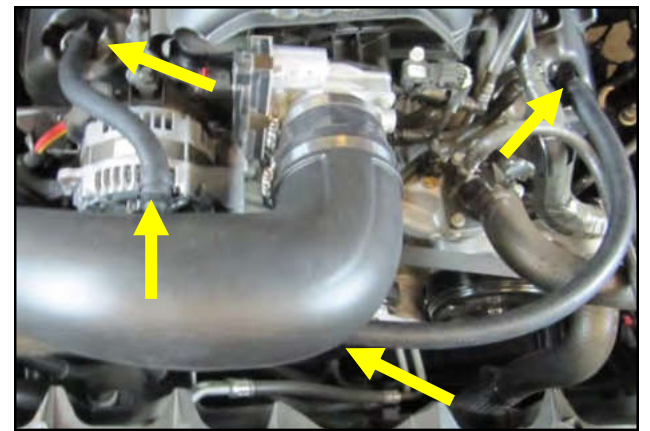

12. Secure the hose ends with the supplied Speed Clamps.



13. Double check your work. Make sure all Clamps are tight and reconnect the negative battery cable.



WARNING! If your vehicle has a Vehicle Emission Control Information decal affixed to the factory air box and it is removed, a new replacement label must be obtained and installed in a readily visible position in the engine compartment in order to remain CARB compliant. Failure to do so will prevent the vehicle from passing a smog check. Replacement labels can be ordered from your local dealership. Regulations state that the VECI label shall not be affixed to any equipment which is easily detached from the vehicle. Label placement, under the hood on a painted surface is recommended.

Thank you for purchasing the Airaid Intake System. Contact Airaid @ (800) 498-6951 8:00 AM - 5:00 PM MST weekdays for questions regarding fit or instructions that are not clear to you. Your Airaid Intake System was carefully inspected and packaged. Check that no parts are missing, or were damaged during shipping. If any parts are missing, contact Airaid. The air filter element is protected from direct exposure to water and debris; care should be taken not to drive through deep water. WATER INGESTION IS THE DRIVERS RESPONSIBILITY! The air filter is reusable and should be cleaned periodically.

FILTER IDENTIFICATION

720-472 Airaid Oiled Media

721-472 Airaid SynthaMax Dry Media - Red

For your Oiled media filter we suggest using the AIRAID Filter Tune-Up Kit!



P/N 790-551 Aerosol Spray
P/N 790-550 Squeeze Spray



SynthaMax

Do Not Oil

Synthamax Air Filters do not require oil. Service air filter as needed by cleaning with common non-petroleum all-purpose household cleaner and water. Simple Green®, Formula 409® or equivalent works great. Apply cleaner to outside of air filter and allow to soak. Then flush filter clean from the inside out with a garden hose and repeat steps if necessary. Do not apply high pressure water or air to clean filter. Allow filter to air dry and reinstall.

NOT LEGAL FOR SALE OR USE ON ANY POLLUTION CONTROLLED MOTOR VEHICLE IN CALIFORNIA OR STATES ADOPTING CALIFORNIA EMISSION PROCEDURES.

See AIRAID.COM for CARB status on each part for a specific vehicle.