

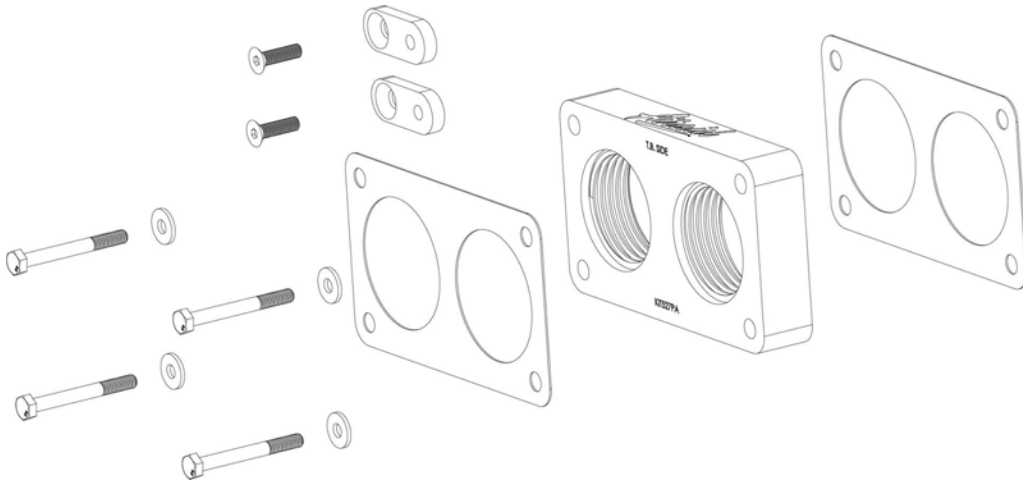

## # 400-527 INSTALLATION INSTRUCTIONS 87-95 Ford Bronco/F-150 5.0, 5.8L

Thank you for purchasing the Airaid Throttle Body Spacer. Please read the instruction manual carefully before proceeding with the installation. Your Airaid Throttle Body Spacer was carefully inspected and packaged. Check that no parts are missing, or were damaged during shipping. If you need any assistance please call 1-800-858-3333 to speak with a representative in our Customer Service Center before returning the product.

*Thank you for selecting AIRAID.*



**THROTTLE BODY SPACERS FOR VEHICLES LISTED ARE  
50 STATE LEGAL. SEE AIRAID.COM FOR CARB STATUS  
ON EACH PART FOR A SPECIFIC VEHICLE.**

<b>Parts List</b>		
AIR-KIT527PA	Aluminum Plate	(1)
AIR-KIT527G	Gasket	(2)
AIR-KIT527H	Hardware	
	Linkage Plates	(2)
	5/16-18 x 2 1/2" Bolts	(4)
	5/16-18 x 3/4" Flat Head Screws	(2)
	5/16" Washers	(4)

<b>Tools List</b>
1/2" Socket
3/16" Hex Key
Standard Screwdriver

## ***Installation Instructions. Read Me!***

1. **DISCONNECT NEGATIVE (-) BATTERY CABLE.**
2. Remove throttle body intake hoses.
3. Remove (2) bolts & save from linkage bracket. **(Ref. C)**
4. Remove (4) bolts from the throttle body. **(Ref. D)**
5. Remove gasket and clean surfaces.
6. Install spacer using (2) gaskets. **(Ref. A)**
  - A. Place one gasket between the throttle body and spacer.
  - B. Place second gasket between the spacer and manifold.
7. Replace (4) bolts using **Step 4** as an example.
8. Locate and install (2) linkage plates using (2) flat head screws. **(Ref. C)**
9. Reinstall linkage bracket using saved bolts. **Refer to Step 3**
10. Inspect & Test the throttle linkage for full open & closed travel before driving. Some cruise or kickdown cables may require adjustment. Please refer to your vehicles service manual for proper adjustment.
11. Reinstall throttle body intake hoses using **Step 2** as an example.
12. Reconnect battery cable. Enjoy!

***The sound of power...The "whistle" means its working!***

**Ref. A-** (1) Power Plate  
(2) Gaskets



**Ref. C-** (2) Linkage Plates  
(2) Flat Head Screws

**Ref. D-** (4) 5/16-18" x 2 1/2" Bolts  
(4) 5/16" Washers

**Ref. B-** Throttle Body

AIR-I40527C  
Rev. 9/2/20