

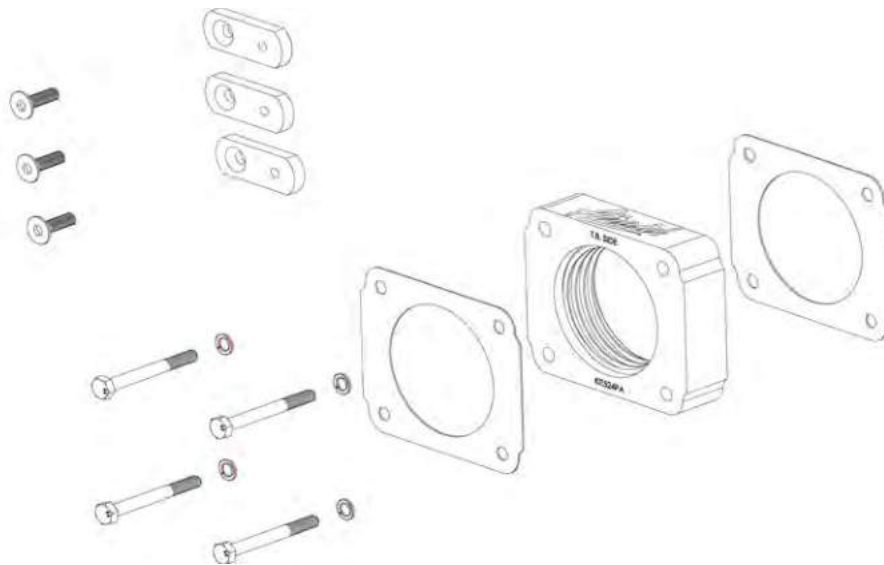

400-590 INSTALLATION INSTRUCTIONS 97-03 Ford F-150/97-04 Expedition 4.6L

Thank you for purchasing the Airaid Throttle Body Spacer. Please read the instruction manual carefully before proceeding with the installation. Your Airaid Throttle Body Spacer was carefully inspected and packaged. Check that no parts are missing, or were damaged during shipping. If you need any assistance please call 1-800-858-3333 to speak with a representative in our Customer Service Center before returning the product.

Thank you for selecting AIRAID.



**THROTTLE BODY SPACERS FOR VEHICLES LISTED ARE
50 STATE LEGAL. SEE AIRAID.COM FOR CARB STATUS ON
EACH PART FOR A SPECIFIC VEHICLE.**

Parts List

AIR-KIT590PA	Aluminum Plate	(1)
AIR-KIT590G	Gasket	(2)
AIR-KIT590H	Hardware	
	Linkage Plates	(3)
	6mm x 16mm Flat Head Screws	(3)
	6mm x 50mm Bolts	(4)
	6mm Washers	(4)

Also available for your F-150/Expedition, the AirAid Intake System p/n 400-109. Call For Details!

Tools List

10mm Socket
5/32 Hex Key
Standard Screwdriver

Installation Instructions. Read Me!

1. **DISCONNECT NEGATIVE (-) BATTERY CABLE.**
2. Remove throttle body intake assembly.
3. Remove (2) bolts & save from linkage bracket. (Ref. "C")
4. Remove (4) bolts from throttle body. (Ref. "D")
5. Remove gasket and clean surfaces.
6. Install spacer with (2) gaskets. (Ref. "A")
 - A. Place one gasket between the throttle body and spacer.
 - B. Place second gasket between the spacer and manifold.
7. Replace (4) 6mm x 50mm bolts (Ref. "D") using Step 4 as an example.
8. Locate and install (2) linkage plates using (2) 6mm x 16mm flat head screws. (Ref. "C")
9. Reinstall linkage bracket using saved bolts. (Refer to Step 3)
10. Install (1) linkage plate for plastic intake cover. (Ref. "C")
11. Inspect & Test throttle linkage for full Open & Closed travel before driving. Some cruise or kickdown cables may require adjustment. Please refer to your vehicles service manual for proper adjusting.
12. Reinstall throttle body intake assembly using Step 2 as an example.
13. Reconnect battery cable. Enjoy!

The sound of power...The "whistle" means its working!

Ref. "C"- (3) Linkage Plates
(3) 6mm x 16mm Flat Head Screws



Ref. "A"- (1) Spacer
(2) Gaskets

Ref. "D"- (4) 6mm x 50mm Bolts
(4) 6mm Washers

Ref. "B"- Throttle Body

AIR-I40590C
Rev. 11.16.20