

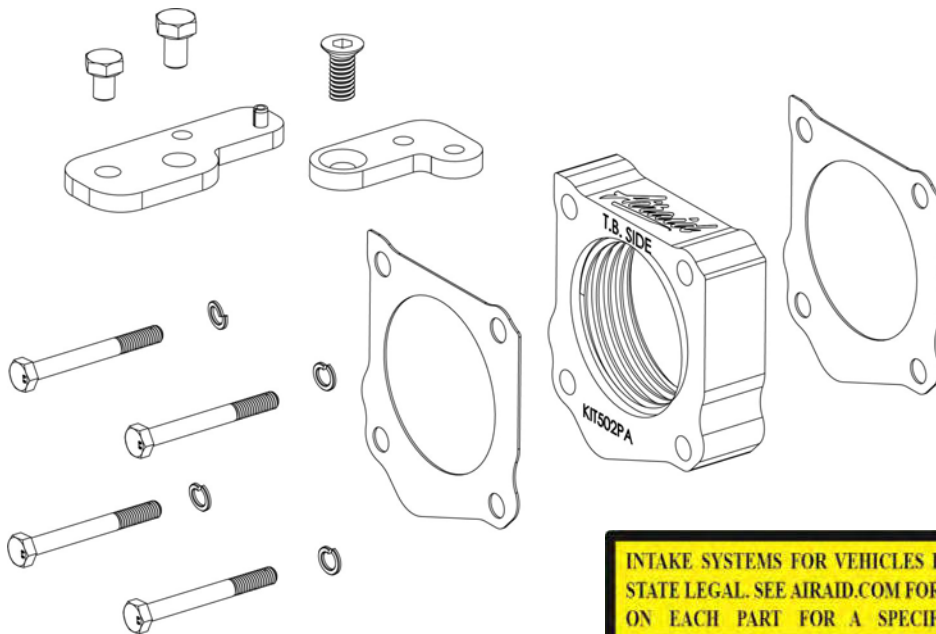

510-502 INSTALLATION INSTRUCTIONS 95-02 Toyota Tacoma/4Runner 3.4L

Thank you for purchasing the Airaid Throttle Body Spacer. Please read the instruction manual carefully before proceeding with the installation. Your Airaid Throttle Body Spacer was carefully inspected and packaged. Check that no parts are missing, or were damaged during shipping. If you need any assistance please call 1-800-858-3333 to speak with a representative in our Customer Service Center before returning the product.

Thank you for selecting AIRAID.



INTAKE SYSTEMS FOR VEHICLES LISTED ARE 50
STATE LEGAL. SEE AIRAID.COM FOR CARB STATUS
ON EACH PART FOR A SPECIFIC VEHICLE.

Included with your Airaid Spacer is a sticker with a California Air Resources Board (C.A.R.B.) Executive Order (EO) number. This sticker must be placed in plain view inside of the engine compartment. Failure to do so may prevent you from passing a smog inspection.

Parts List		
AIR-KIT502PA	Aluminum Plate	(1)
AIR-KIT502G	Gasket	(2)
AIR-KIT502H	Hardware	
	8mm x 90mm Bolts	(4)
	8mm Lock Washers	(4)
	Linkage Plate	(1)
	10mm x 20mm Bolt	(1)
	Extension Plate	(1)
	8mm x 16mm Flat Head Screw	(1)
	8mm x 10mm Bolt	(1)

Also available for your 99-02 Tacoma, the Airaid Intake System p/n 510-134.
Call for details!

Tools List
17mm Socket
13mm Socket
4mm Hex Key
Standard Screwdriver

Installation Instructions. Read Me!

1. **DISCONNECT NEGATIVE (-) BATTERY CABLE.**
2. Remove throttle body air intake assembly.
3. Remove throttle linkage bracket and save 10mm bolt. (Ref. "D")
4. Remove vacuum line clip, and also linkage bracket used on some models. Save the 8mm bolt for models having a linkage bracket. (Ref. "E")
5. Remove nuts and studs from the throttle body. (Ref. "C")
6. Install the power plate using (2) gaskets, (4) 8mm bolts, and (4) 8mm lock washers. (Ref. "A", "B", "C")
 - A. Install one gasket between the throttle body and power plate.
 - B. Install second gasket between the power plate and manifold.
7. Install throttle linkage plate using a 10mm x 20mm bolt and reinstall the throttle linkage bracket using saved 10mm bolt. (Ref. "D")
8. Install extension plate using 8mm flat head screw and reinstall linkage bracket used on some models with saved 8mm bolt. Attach vacuum line clip to bottom side of extension plate using furnished 8mm bolt. (Ref. "E")
9. Inspect & Test throttle linkage for full open & closed travel before driving. Some cruise or kickdown cables may require adjustment. Please refer to your vehicles service manual for proper adjusting.
10. Reinstall air intake system using **Step 2** as an example.
11. Reconnect battery cable. Enjoy!

The sound of power...The "whistle" means its working!

Ref. "A"- Throttle Body

Ref. "B"- (1) Power Plate
(2) Gaskets

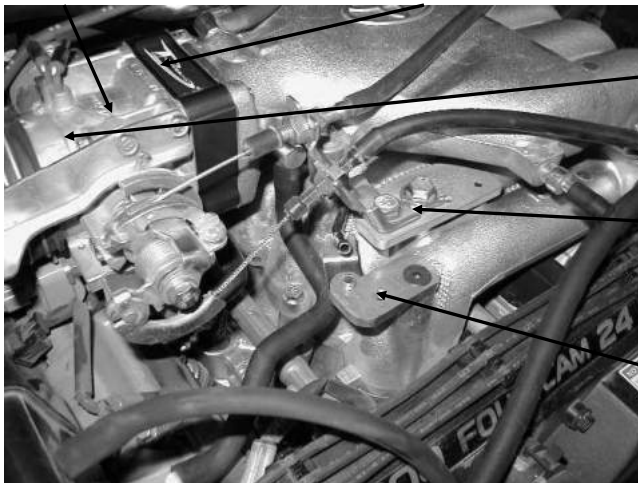

Ref. "C"- (4) 8mm x 90mm Bolts
(4) 8mm Lock Washers

Ref. "D"- (1) Linkage Bracket
(1) 10mm x 20mm Bolt

Ref. "E"- (1) Extension Plate
(1) 8mm x 16mm Flat Head Screw
(1) 8mm x 10mm Bolt

AIR-I51502C
Rev. 06.16.20