

BBK PERFORMANCE LLC  
3060 Performance Circle  
Deland, FL 32724

For any questions, email us:  
TECH@BBKPERFORMANCE.COM



## INSTALLATION INSTRUCTIONS - INS087

# THROTTLE BODY 62MM

Part # 1724 / 1991 - 2003 Jeep Cherokee/Wrangler 4.0L

Part # 17240 / 2004 - 2006 Jeep Cherokee/Wrangler 4.0L



**SPECIAL TOOLS REQUIRED:** No special tools required.



**INSTALL TIME:** Approximately 1 hour.



**DIFFICULTY:** Easy.

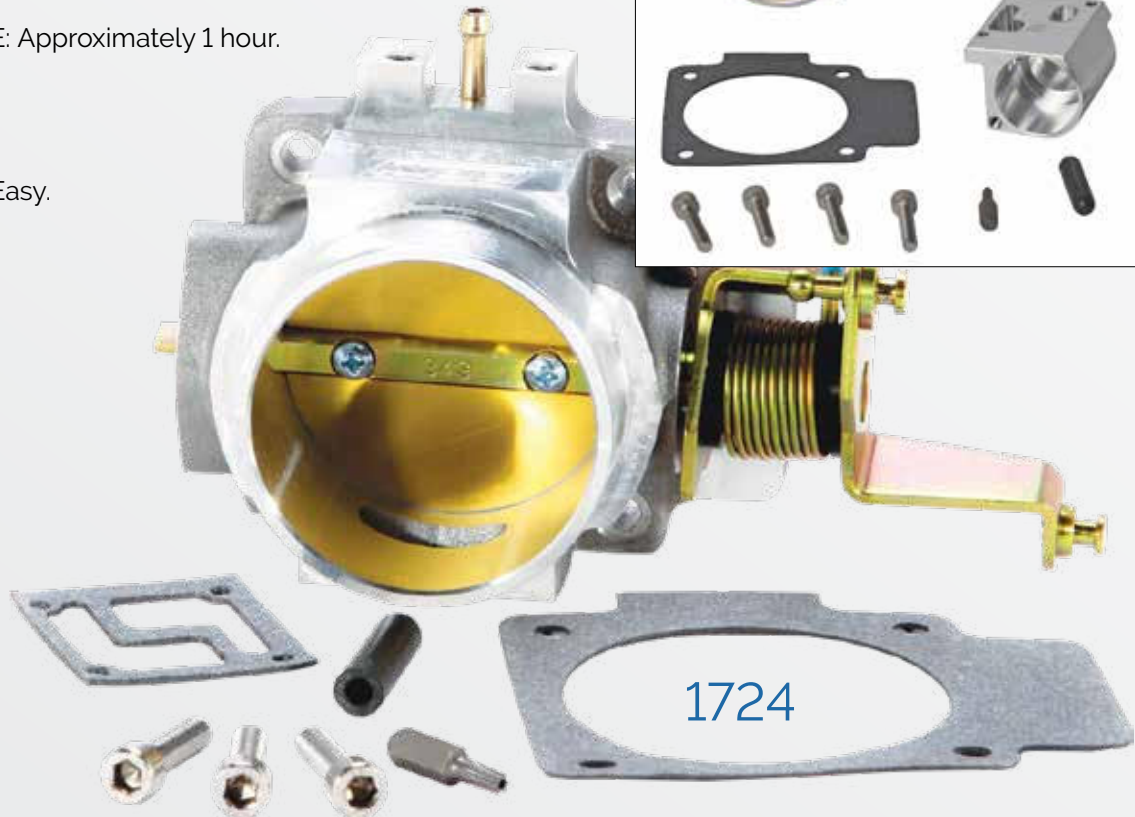

**MADE IN U.S.A.**

**IMPORTANT:** All appropriate safety equipment and gear must be used during the installation of this or any BBK Performance products or any time you work on a vehicle. BBK Performance accepts no responsibility for injuries or damage caused by or during the installation of this product.

UPDATED LAST: March 2019

FOLLOW THESE INSTRUCTIONS CAREFULLY TO ENSURE CORRECT FITMENT AND OPERATION

### STEP 1

Disconnect the negative (-) battery terminal.

### STEP 2



Loosen the (2) clamps that hold the air inlet tube to the throttle body and the air box.



Unclip the cable attachments from the throttle linkage.

### STEP 3

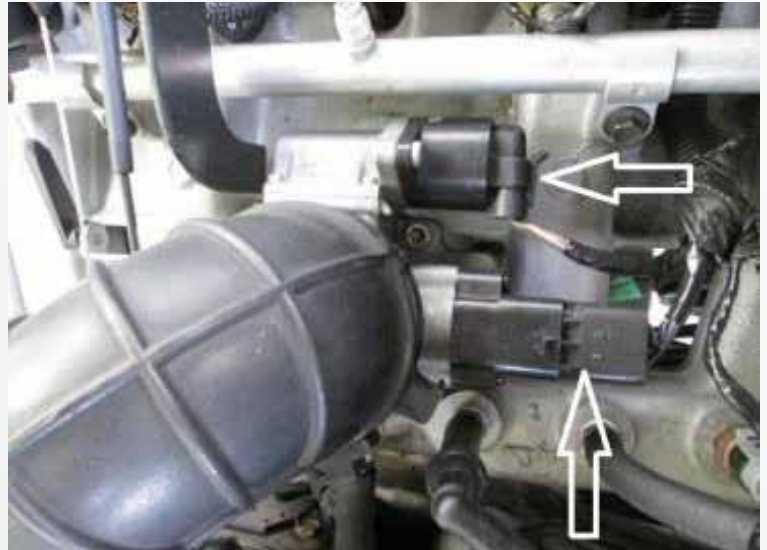

Unplug the electrical connections at the IAC, TPS, and MAP sensors.

NOTE: some models do not use a throttle body mounted MAP sensor. For those vehicles we supply a vacuum cap to place over the vacuum bung that is installed on the BBK Throttle Body.

### STEP 4

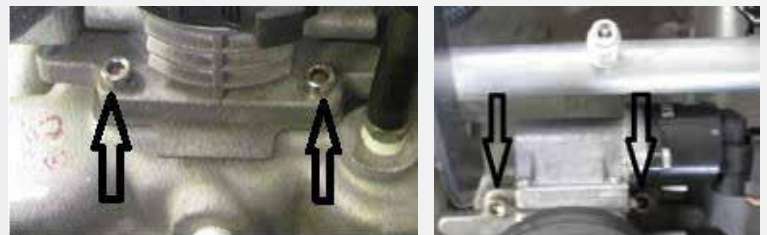

Unbolt and remove the throttle body from the intake manifold.

 MADE IN U.S.A. 

IMPORTANT: All appropriate safety equipment and gear must be used during the installation of this or any BBK Performance products or any time you work on a vehicle. BBK Performance accepts no responsibility for injuries or damage caused by or during the installation of this product.

UPDATED LAST: March 2019

FOLLOW THESE INSTRUCTIONS CAREFULLY TO ENSURE CORRECT FITMENT AND OPERATION

### STEP 5



Remove the IAC, TPS, and MAP sensor. (if applicable)



To install the IAC valve into the supplied adapter. Line up the bolt holes and press the IAC valve into the adapter supplied in the kit. Using the supplied bolt tighten it down to secure the two pieces together.

**NOTE: FOR PART # 1724 1991-2003 THIS ADAPTER IS NOT SUPPLIED.** Unbolt the for crews that hold the IAC valve and its mounting plate and transfer it over to the BBK Throttle body utilizing the supplied gasket and original hardware.

### STEP 6

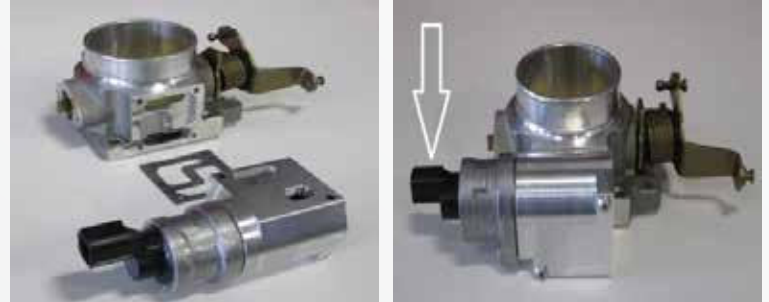

Using the new gasket and hardware supplied in the kit assemble the IAC valve and adapter to the BBK Throttle Body.

**NOTE:** Be sure to align the gasket properly and assemble the IAC valve and adapter with the electrical connector facing the opposite side of the throttle body that the cable linkage is on.

### STEP 7

Install the TPS, and MAP sensor (if applicable) using the original hardware.

**NOTE:** When installing the MAP sensor, be sure to make a good connection between the rubber hose and the vacuum fitting.

### STEP 8

Mount the BBK Throttle Body onto the intake manifold using the supplied base gasket and the (4) supplied ( M6x1.0x24mm ) mounting bolts. Plug in the electrical connections at the IAC, TPS, MAP sensors. Clip the cable connections onto the linkage of the BBK Throttle Body.

Re-install the air intake hose assembly.

Reconnect the Negative (-) battery terminal.

 **MADE IN U.S.A.** 

**IMPORTANT:** All appropriate safety equipment and gear must be used during the installation of this or any BBK Performance products or any time you work on a vehicle. BBK Performance accepts no responsibility for injuries or damage caused by or during the installation of this product.

UPDATED LAST: March 2019