

BLACK SERIES AIR INTAKE SYSTEM

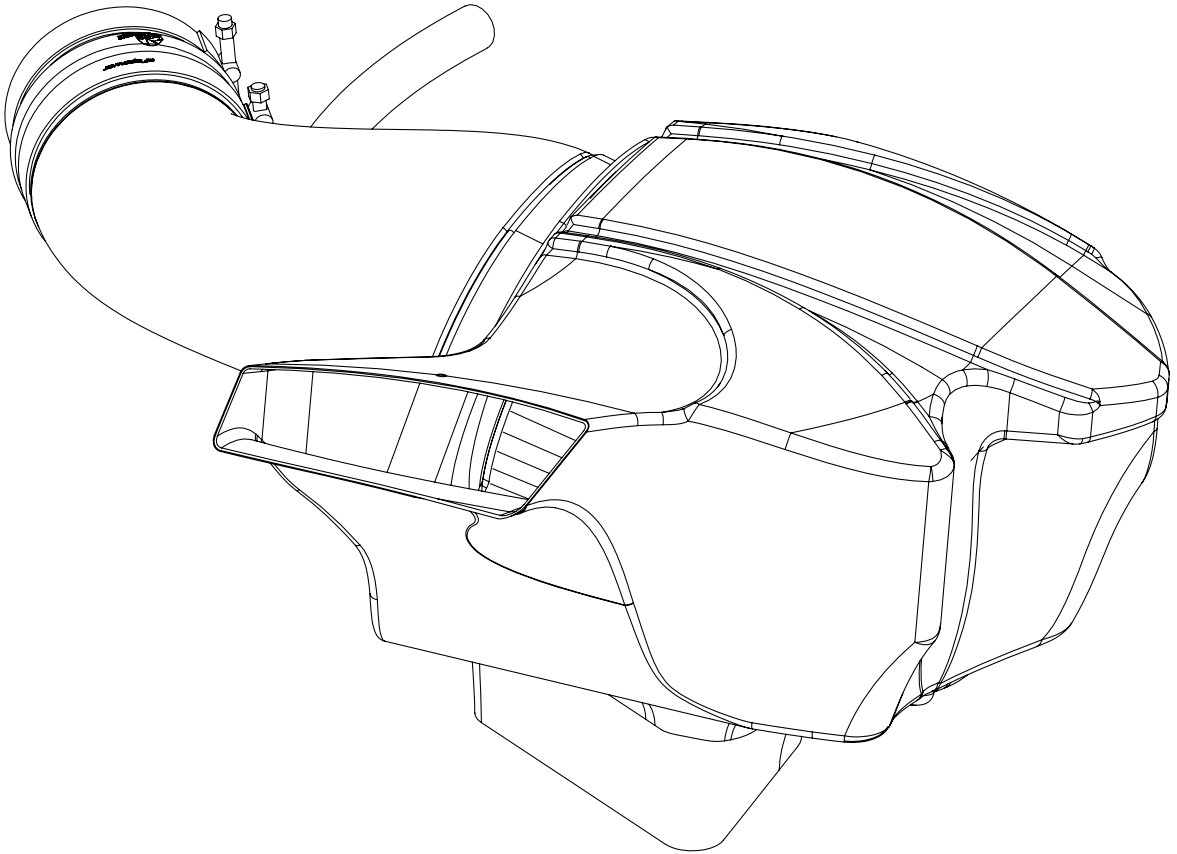

advanced FLOW engineering Black Series Carbon Fiber Air Intake

Instruction Manual P/N: 58-10001D / 58-10001R

Make: **Jeep** Model: **Grand Cherokee (WK2) SRT-8/SRT** Year: **2012-2020** Engine: **V8-6.4L HEMI**
Make: **Dodge** Model: **Durango SRT** Year: **2018-2020** Engine: **V8-6.4L HEMI**



- Please read the entire instruction manual before proceeding.
- Ensure all components listed are present.
- If you are missing any of the components, call customer support at 951-493-7100.
- Ensure you have all necessary tools before proceeding.
- Do not attempt to work on your vehicle when the engine is hot.
- Disconnect the negative battery terminal before proceeding.
- Retain factory parts for future use.

Label	Qty.	Description	Part Number
A1	1	Air Filter (Pro 5R)	24-91101
A2	1	Air Filter (Pro DRY S)	21-91101
B	1	Tube	05-76206C1
C	1	Housing	05-76206C2
D	1	Clamp, T-Bolt (4-1/8" - 4-1/2")	03-50262
E	1	Coupling, Silicone Hump	05-01386
F	1	Clamp, T-Bolt (3-9/16" - 3-7/8")	03-50498
G	1	Emblem, Black Series	06-00142
H	1	Clamp, Mini	03-50078
I	1	Hose, Silicone Breather: 5/8" (7" inch)	05-01502

Installation will require the following tools:

8mm nut driver, 10mm nut driver, 10mm deep socket, 1/4" ratchet, flat head screw driver.

Recommended: Panel clip pliers or panel popper, silicone lubricant.

Warranty Information available at <https://afepower.com/contact#warranty>

Note: Legal in California for use on race vehicles only. The use of this device on vehicles used on public streets or highways is strictly prohibited in California and others states that have adopted California emission regulations.

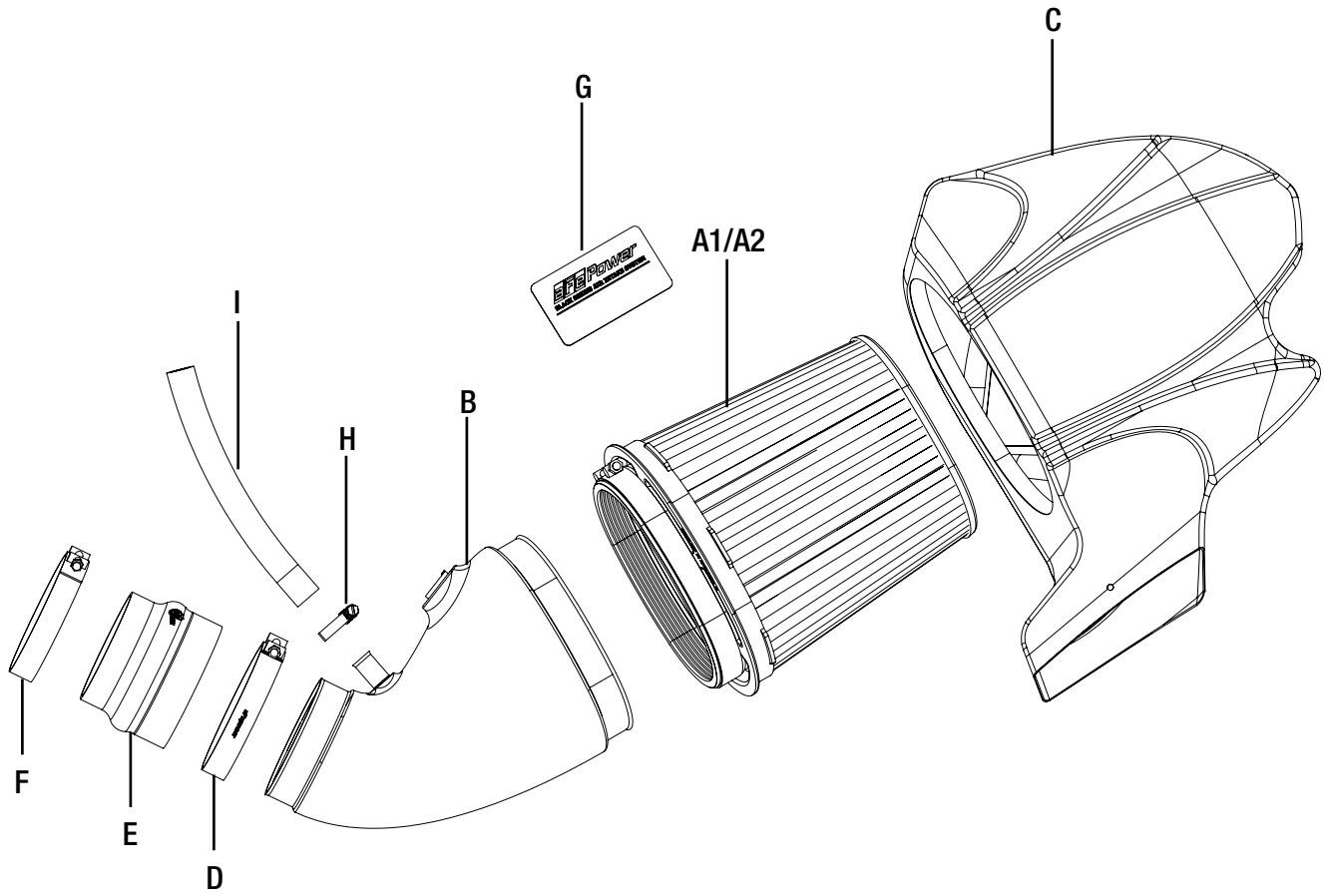



REMOVAL

Figure A

Refer to Figure A for Step 1

Step 1: Remove engine cover trim (1). Removal of the oil cap may be necessary.



Figure B

Refer to Figure B for Steps 2-5

Step 2: Disconnect the temperature sensor harness (2) from the factory intake tube.

Step 3: Disconnect the Crank Case Vent (CCV) hose (3) from the engine valve cover.

Step 4: Using an 8mm nut driver, loosen the clamp (4) at the throttle body end of the factory tube.

Step 5: Lift and remove the entire intake assembly at this time.



Refer to Figure C for Steps 6-8

Step 6: Pull back the factory rubber trim seal (5) to where you can see a green plastic push clip, as shown in the inset picture.

Step 7: Using panel clip pliers (recommended), carefully remove the trim from the plastic block off plate.

***Take care not to damage these clips as they will be reinstalled.**

Step 8: Remove 2-3 clips on either side of the center.



Figure D

Refer to Figure D for Steps 9-11

Step 9: First pull the center of the black plastic push clips up ⑥ as shown.

Step 10: Then carefully remove each push clip.

Step 11: Lift and remove the plastic block off plate.



Figure E

Refer to Figure E for Steps 12-14

- Step 12: Partially pull the plastic liner up so the wire shown (7) can be tucked behind.
- Step 13: Tuck the wire below the plastic intake mounting stud as shown in the inset picture.
- Step 14: Place the plastic liner back in its original position.



Figure F

Refer to Figure F for Step 15

Step 15: Using the provided rubber hose, connect one end to the engine crank case fitting (8) as shown.

Note: It may help to apply a small amount of lubricant on the inside of the rubber hose to slip over the CCV fitting.

**Figure G****Refer to Figure G for Steps 16-19**

Step 16: Insert the carbon fiber tube into the filter (9) until there is no gap between them.

Step 17: Slide the reducer hump coupler over the tube as shown (10), followed by the larger 03-50262 t-bolt clamp.

Step 18: Position the clamp as shown in the photo and tighten the 03-50262 t-bolt clamp at this time.

Step 19: Slide the smaller 03-50265 t-bolt clamp over the coupler (11) but do not tighten at this time



Figure H

Refer to Figure H for Step 20

Step 20: Insert the tube/filter assembly into the housing (12) as shown. Press until you feel or hear all six (6) of the tabs seat themselves in the housing. Gently pull on the tube to verify filter is properly seated.



Figure I

Refer to Figure I for Step 21

Step 21: Remove 2 of the 3 grommets from the bottom of the factory housing and insert in the bottom of the aFe POWER carbon fiber housing (13) as shown above.



Figure J

Refer to Figure J for Steps 22-26

Step 22: While holding the intake assembly; first slide the coupling over the throttle body, then compress the silicone coupling and lower the intake onto the factory mounting locations. Press down firmly to securely seat the housing.

Step 23: Attach the other end of the CCV hose to the aFe POWER tube (14) .

Step 24: Insert the factory temp sensor into the fitting and secure by turning clockwise. (15)

Step 25: Re-connect the temperature sensor wiring harness.

Step 26: Re-install rubber trim seal into the factory locations and onto the aFe POWER housing (16).

**Figure K****Refer to Figure K for Steps 27-29**

Step 27: Align tube where there are no gaps and tighten all clamps.

NOTE: Notice the cutout on the bottom of the intake tube. On some vehicles, the AC line may need to be moved to give more clearance under the tube and fit in this area. Do this by gently moving the line left or right through its mounting bushing (17).

Step 28: Reinstall engine cover trim.

Step 29: Place the aFe POWER Black Series Emblem in any desired location. Your installation is now complete. Thank you for choosing aFe POWER!

NOTE: Check all bolts, clamps, and connections after 100-200 miles.



Page left blank intentionally.

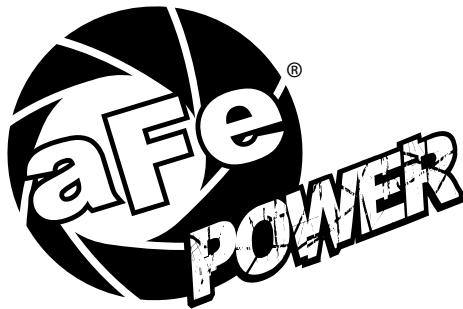

advanced FLOW engineering, inc.
252 Granite Street Corona, CA 92879
<https://afepower.com/contact>