

advanced FLOW engineering

**Instruction Manual** P/N: 58-10004D/58-10004R

Make: **BMW** Model: **M2 (F87)**

Make: **BMW** Model: **335i/ix (F30/F34)**

Make: **BMW** Model: **435i/ix (F32/F33/F36)**

Make: **BMW** Model: **M135i/ix/M235i (F20/F21/F22)**

Year: **2016-2018** Engine: **L6-3.0L (t) N55**

Year: **2012-2015** Engine: **L6-3.0L (t) N55**

Year: **2014-2016** Engine: **L6-3.0L (t) N55**

Year: **2012-2016** Engine: **L6-3.0L (t) N55**



- Please read the entire instruction manual before proceeding.
- Ensure all components listed are present.
- If you are missing any of the components, call customer support at 951-493-7100.
- Ensure you have all necessary tools before proceeding.
- Do not attempt to work on your vehicle when the engine is hot.
- Disconnect the negative battery terminal before proceeding.
- Retain factory parts for future use.

Label	Qty.	Description	Part Number
A1	1	Air Filter (Pro DRY S For 58-10004D)	21-91108
A2	1	Air Filter (Pro 5R For 58-10004R)	24-91108
B	1	Housing, Carbon Fiber	05-76311C2
C	1	Tube, Carbon Fiber	05-82202C1
D	1	Cap, Vinyl: 3/4" ID	03-50035
E	1	Torx Bit: T20	03-50066
F	1	Black Series Plate	06-00142
G	2	Screw, Torx: M4	03-50490

Tools needed: 7mm, 8mm Nut driver, 10mm Nut Driver, 1/4" Ratchet, 10mm, 13mm Socket, Flathead Screw Driver, Pliers.

Warranty Information available at <https://afepower.com/contact#warranty>

Note: Legal in California for use on race vehicles only. The use of this device on vehicles used on public streets or highways is strictly prohibited in California and others states that have adopted California emission regulations.

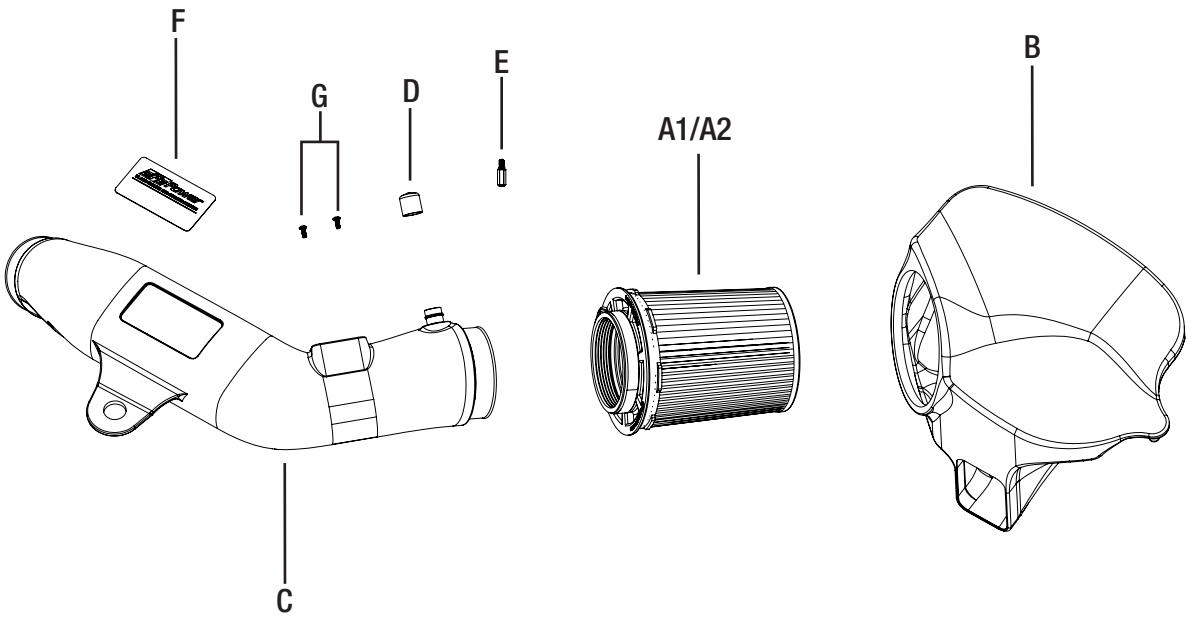



Figure A

**Refer to Figure A for Step 1**

Step 1: If your vehicle is equipped with a brace, take it off by removing the four 13mm bolts.



Figure B

**Refer to Figure B for Steps 2-5**

Step 2: Disconnect the MAF sensor.

Step 3: Unplug the vacuum line (if your vehicle is equipped with one)

Step 4: Loosen the clamp on factory intake tube.

Step 5: Remove the factory intake system out of the vehicle by pulling it off the mounting grommets.



Figure C

**Refer to Figure C for Steps 6-8**

- Step 6: Remove the MAF sensor off the factory intake using the furnished T20 torx and install onto aFePower intake tube with the furnished screws.
- Step 7: Remove OE grommet off intake tube and install on aFe intake tube.
- Step 8: For vehicle not equipped with vacuum line, simply cap off the aluminum fitting on the tube with the provided cap.



Figure D

**Refer to Figure D for Step 9**

Step 9: Install the aFePower air filter into the housing. Push it firmly until it lock into place.

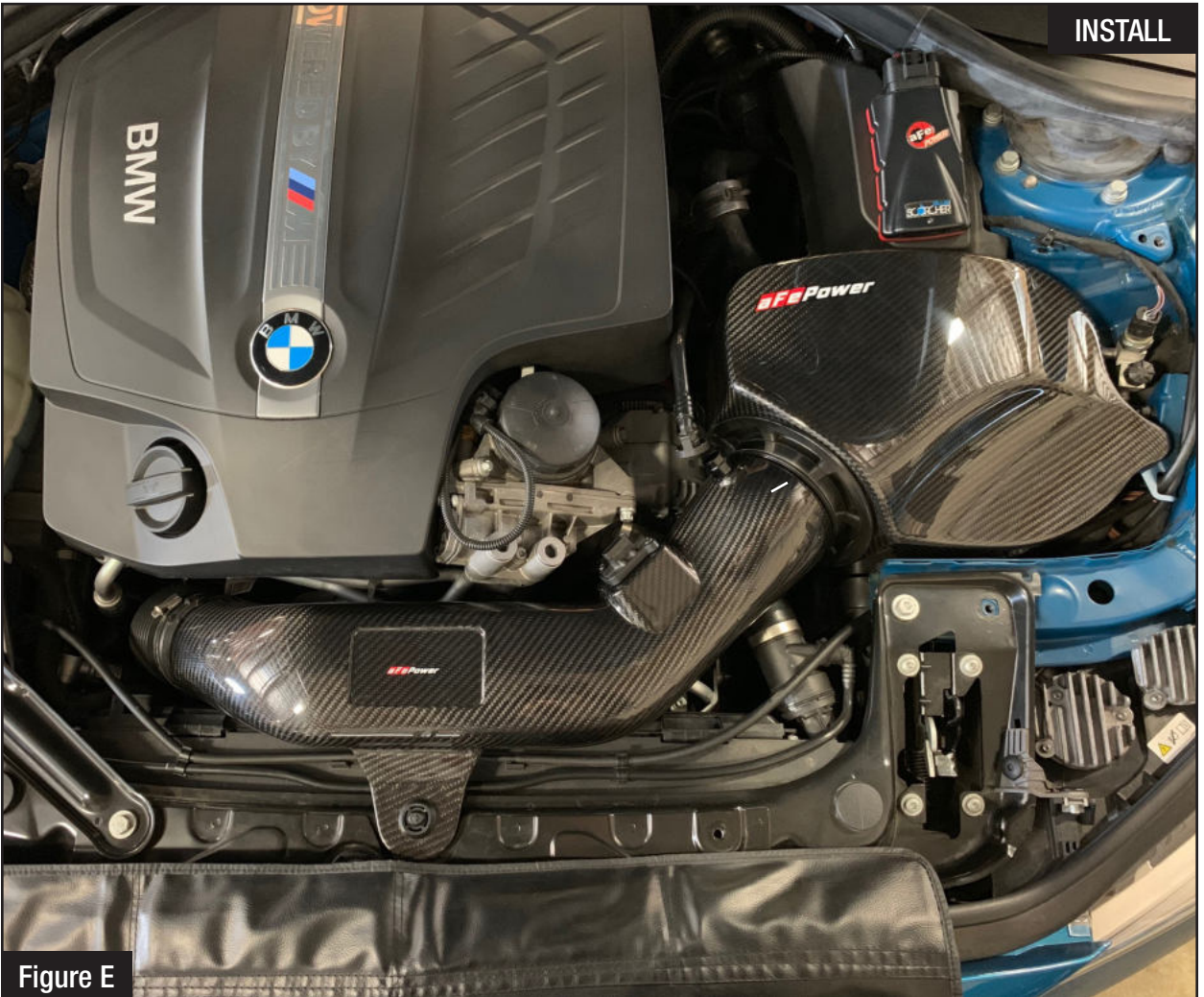

Figure E

**Refer to Figure E for Steps 10-11**

Step 10: Install the aFePower housing in the vehicle by pushing it into the factory grommets. Make sure housing line up to the factory air inlet duct.

Step 11: Slide the aFePower intake tube into factory inlet tube and into the aFePower filter. Then push the grommet in the mounting location. Align tube correctly and tighten all clamps.



Figure F

### **Refer to Figure F for Steps 12-16**

Step 12: Lift up the engine cover and re-route the MAF harness around the oil filter housing. Then re-connect it to the MAF sensor.

Step 13: Re-connect the vacuum line to aluminum fitting (automatic vehicle only)

Step 14: Re-install the factory brace with the four 13mm bolts.

Step 15: Place the Black Series Plate into the recess location on the tube.

Step 16: Verify all clamps are secure and re-check periodically. Your Installation is now complete.

Page left blank intentionally

Page left blank intentionally

advanced FLOW engineering, inc.