

advanced FLOW engineering

Instruction Manual P/N: 53-10008S/53-10008SR/53-10008SL/53-10008SC

Make: Ford	Model: F-150 EcoBoost	Year: 2015-2020 Engine: V6-2.7L(tt)/3.5L(tt)
Make: Ford	Model: F-150	Year: 2018-2020 Engine: V6-3.3L
Make: Ford	Model: F-150 Raptor	Year: 2017-2020 Engine: V6-3.5L(tt)
Make: Ford	Model: F-150	Year: 2015-2020 Engine: V8-5.0L
Make: Ford	Model: F-150	Year: 2015-2017 Engine: V6-3.5L
Make: Ford	Model: F-150	Year: 2018-2020 Engine: V6-3.0L(td)



- Please read the entire instruction manual before proceeding.
- Ensure all components listed are present.
- If you are missing any of the components, call customer support at 951-493-7185.
- Ensure you have all necessary tools before proceeding.
- Do not attempt to work on your vehicle when the engine is hot.

Retain factory parts for future use.

Label	Qty.	Description	Part Number
A1	1	Scoop, Black	05-53112B3
A2	1	Scoop, Red	05-53112R3
A3	1	Scoop, Blue	05-53112L3
A4	1	Scoop, Carbon Fiber	05-5310008C3
B	2	Retainer Clip	03-50616
C	1	Seal, Trim: 7/16" (15.5")	05-00072

Installation will require the following tool(s):
8mm, 13mm nut driver or socket and extension, Flat screwdriver.

Warranty Information available at: <https://afepower.com/contact#warranty>

Emission Disclaimer:

This product is not currently CARB exempt and is not available for purchase in California or for use on any vehicle registered with the state of California Department of Motor Vehicles.

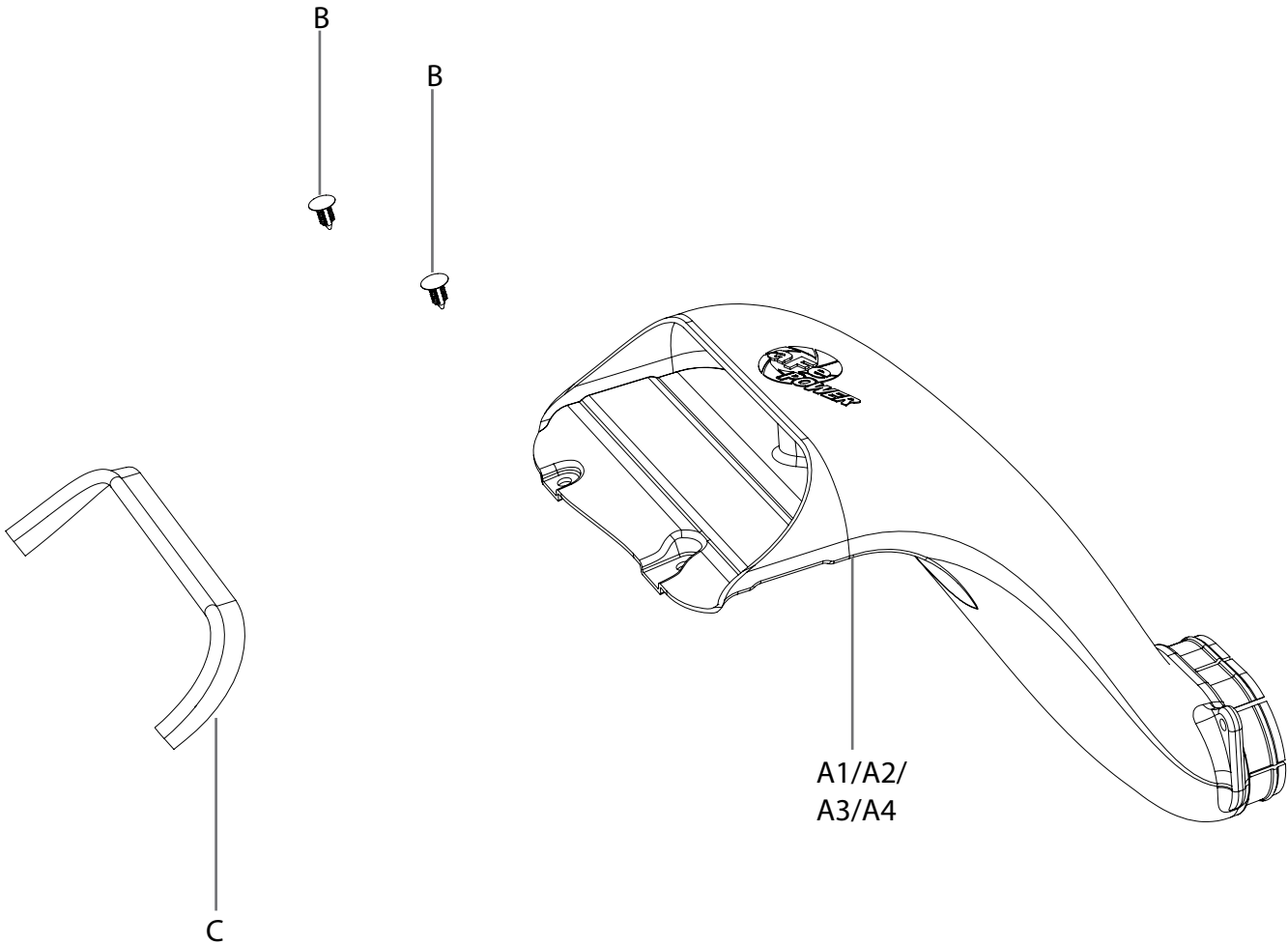



Refer to Figure A.

This aFe POWER scoop is designed to work with the aFe POWER Quantum air intake kits, the aFe POWER Magnum FORCE air intake kits and the factory air intake system.

NOTE: This scoop does NOT fit aFe POWER Momentum intake systems.



FigureB

Refer to Figure B for Steps 1-2.

Step 1: Remove the aFe POWER or factory intake from the vehicle.

Step 2: Remove the screw securing the scoop to the factory housing then pull the scoop out of the factory housing.



Figure C

Refer to Figure C for Step 3.

Step 3: For installation on the factory housing, press the aFe POWER scoop into the factory housing and secure it using the factory screw.



Figure D

Refer to Figure D for Step 4.

Step 4: For the installation on the Quantum housing, push the aFe POWER scoop into the Quantum housing then secure it with the M6 screw and washer that was provided with the aFe Quantum intake kit.



Figure E

Refer to Figure E for Steps 5-7.

Step 5: Reinstall the housing and scoop assembly into the vehicle. Secure the scoop using the provided plastic rivets.

Step 6: Install the seal trim on the top edge of the aFe POWER scoop.

Step 7: The installation of the aFe POWER scoop is complete. Finish installing the rest of the air intake system. Thanks for choosing aFe POWER.

NOTE: Check all bolts, clamps and connectors after 100-200 miles.

Page left blank intentionally



PAGE LEFT BLANK INTENTIONALLY

PAGE LEFT BLANK INTENTIONALLY



advanced FLOW engineering, inc.
252 Granite Street Corona, CA 92879
<https://afepower.com/contact>