

advanced FLOW engineering

Dynamic Air Scoop D.A.S.

**Instruction Manual** P/N: 54-13015S/SL/SR

Make: Ford Model: Mustang Year: 2015-2020 Engine: I4-2.3L(t)/V6-3.7L/V8-5.0L (GT only)



- Please read the entire instruction manual before proceeding.
- Ensure all components listed are present.
- For technical support please call 951-493-7185.
- Ensure you have all necessary tools before proceeding.
- Do not attempt to work on your vehicle when the engine is hot.
- Retain factory parts for future use.

| Label | Qty. | Description   | Part Number  |
|-------|------|---------------|--------------|
| A1    | 1    | Scoop (Black) | 05-5413015B3 |
| A2    | 1    | Scoop (Blue)  | 05-5413015L3 |
| A3    | 1    | Scoop (Red)   | 05-5413015R3 |

**Installation will require the following tools:**

Flathead screwdriver (or panel clip removal tool) and 5.5mm/7mm/8mm/10mm nut drivers

Warranty Information available at: <https://afepower.com/contact#warranty>

**Emissions Disclaimer:** This product is not currently CARB exempt and is not available for purchase in California or for use on any vehicle registered with the California Department of Motor Vehicles.

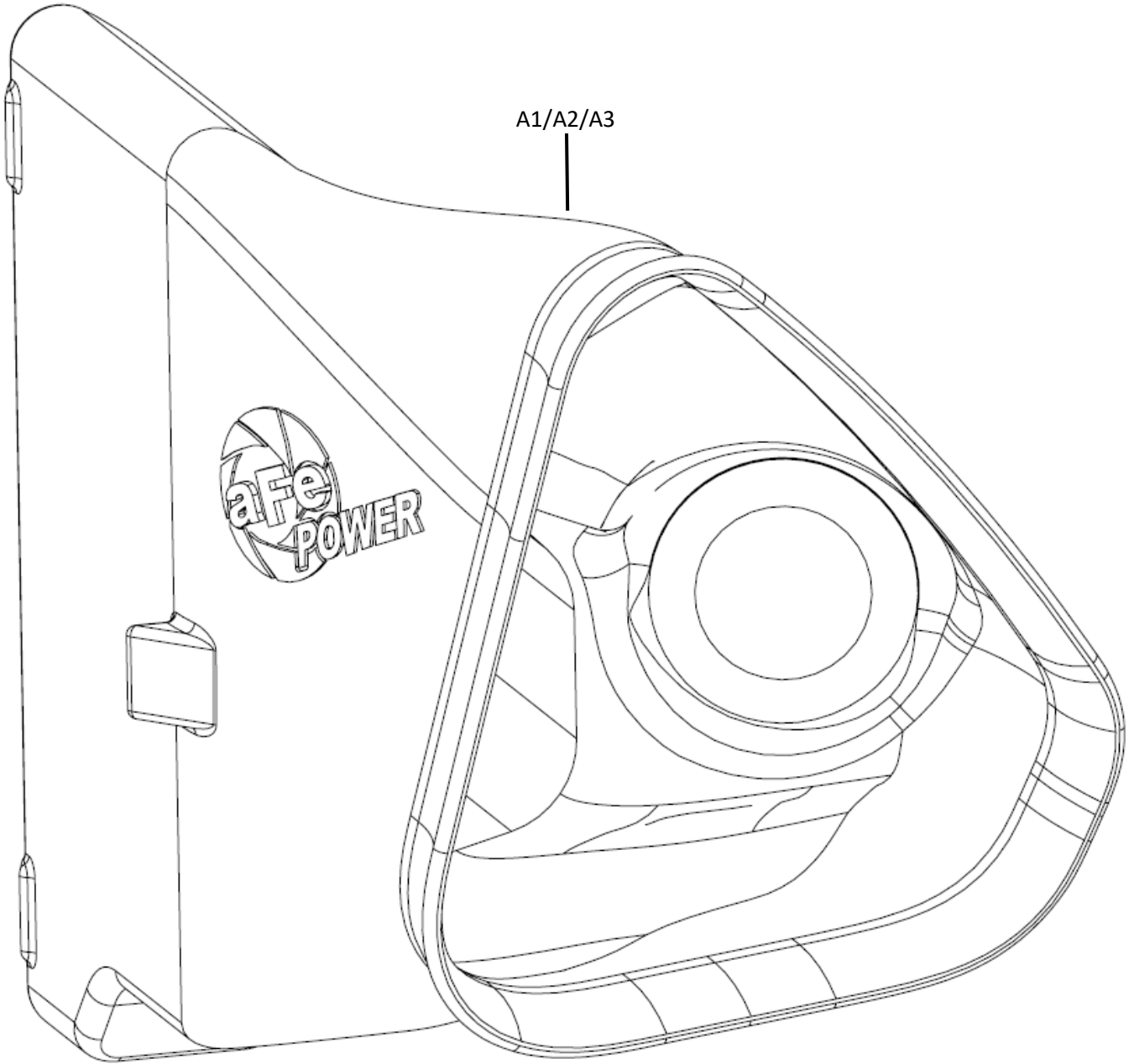

A1/A2/A3

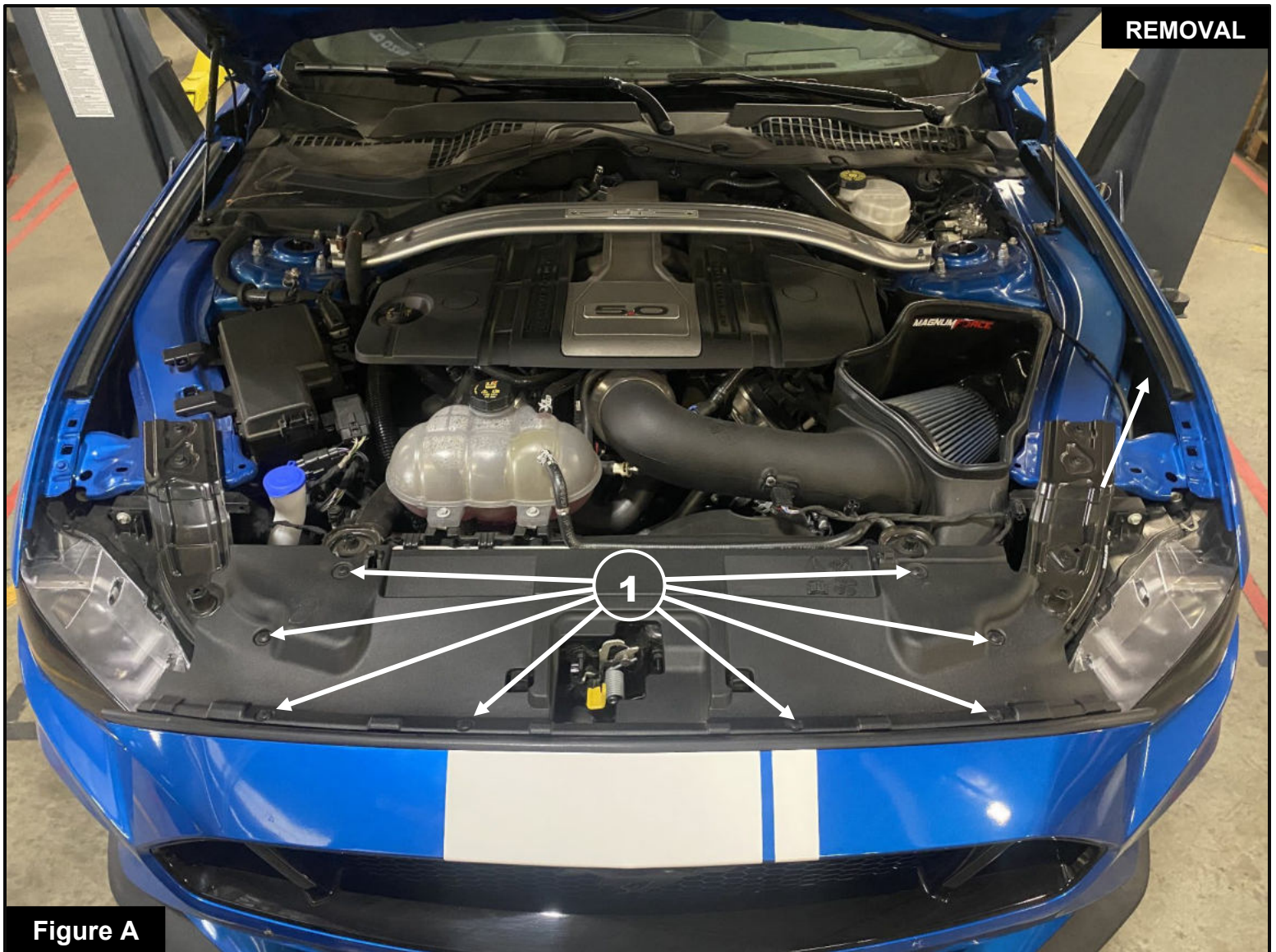

**Refer to Figure A for Steps 1-2**

- Step 1: Open the vehicle's hood and locate the 8 plastic retaining clips ① that hold on the plastic cover.
- Step 2: Using a flat head screwdriver or panel clip removal tool, remove the 8 plastic retaining clips and remove the plastic cover.

**Figure B**
**Refer to Figure B for Steps 3-5**

Step 3: With the plastic cover removed, locate the six screws (2) holding on the upper portion of the bumper.

Step 4: Using an 8mm nut driver, remove the six screws.

Step 5: Using a 5.5mm nut driver, remove the two screws (3) on the outer portions of the bumper.

**Figure C****Refer to Figure C for Steps 6-7**

Step 6: Underneath the front bumper, locate the thirteen screws (4) to be removed.

Step 7: Using a 7mm nut driver, remove the thirteen screws.

**Figure D****Refer to Figure D for Steps 8-10**

Step 8: Starting with the driver's side wheel well, locate the 3 plastic clips ⑤.

Step 9: Using your finger, push on the center of the plastic clip to release the two upper clips. Use a flathead screwdriver or panel clip removal tool to remove the bottom clip.

Step 10: Move to the passenger side and perform steps 8 and 9.



### Refer to Figure E for Steps 11-14

Step 11: Pull back on the fender liner and locate the two nuts ⑥.

**\*NOTE:** 2015-2017 models have a screw instead of two nuts on the inside of the fender.

Step 12: Using a 10mm nut driver, remove the nuts on the driver and passenger sides.

**\*NOTE:** For 2015-2017 models, use a 7mm nut driver and remove 1 screw per side.

Step 13: Un-plug the fog lights and turn signals before completely removing the bumper from the vehicle.

Step 14: Remove the bumper from the vehicle and set aside.



**Figure E**

**Refer to Figure E for Steps 15-18**

Step 15: Locate the air inlet ⑦.

Step 16: Install your aFe POWER Dynamic Air Scoop by inserting it into the air inlet. Push inward until you feel the locking tabs snap into place.

Step 17: Re-install the bumper following the steps in the reverse order.

Step 18: Your installation is now complete.

**NOTE: Check all fasteners and connectors after 100-200 miles.**



Page left blank intentionally



Page left blank intentionally



advanced FLOW engineering, inc.

252 Granite Street Corona, CA 92879

<https://afepower.com/contact>