



INSTALLATION INSTRUCTIONS

MAKE: AUDI

MODEL: A4 09; A5 08-11; Q5 09-12 V6-3.2L;
A4 09-12 V6-3.0L; S4 09-12; S5 10-12 V6-3.0L (sc);
S5 08-12 V8-4.2L; A4 Quattro 2012 V6-3.0L

OER
AIR FILTER
10/11-10121



Parts Included:

- Air Filter
- Washer, Star #8
- Nut, Hex Tooth

Qty

1
2
2

Tools Needed:

- Ratchet
- 9/32" Socket
- T20 Torx Screwdriver

CAUTION: Allow time for your vehicle to cool down prior to installation. When working on your vehicle proceed with caution. Wear protective safety equipment; eye goggles and gloves to ensure a safe installation. **aFe recommends professional installation on this product.**

1. Disconnect the mass air flow sensor housing from the intake system by disconnecting the two metal retainer clips.
2. Using a T20 torx screwdriver, remove the two screws located near the mass air flow sensor, then continue removing the five located on the top on the of the stock air box.
3. Lift the top of the stock air box out of the vehicle.
4. Remove the OE Air filter from the top of the stock air box using a T10 torx screwdriver. (The gasket will not be used with your new aFe air filter)
5. Install your aFe air filter using the 9/32" socket onto the stock air box top using the hardware supplied. **DO NOT OVER TIGHTEN!**
6. Place the top half of the stock airbox into the vehicle and tighten the seven screws removed in step 2.
7. Apply a lubricating substance on the inside of the aFe filter urethane flange seal to help insert the mass air flow sensor into position. (see below)

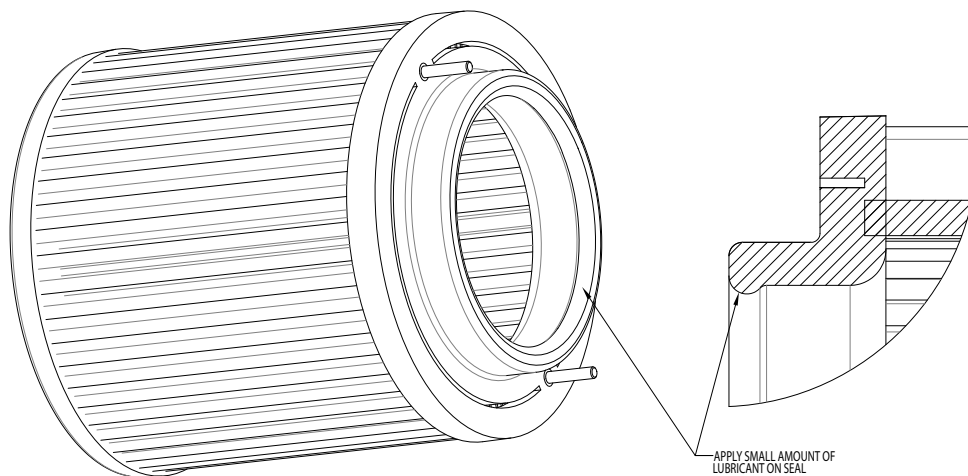

8. Gently slide the mass air flow sensor into position and lock the two metal clips to hold it in place.
9. Your installation is now complete.