

advanced FLOW engineering

Instruction Manual P/N: 51-22642-B / 54-22642-B

Make: **Ford** Model: **F-150** Year: **2015-2021** Engine: **V6-2.7L (tt) EcoBoost**

Make: **Ford** Model: **F-150** Year: **2015-2016** Engine: **V6-3.5L (tt) EcoBoost**



- Please read the entire instruction manual before proceeding.
- Ensure all components listed are present.
- If you are missing any of the components, call customer support at 951-493-7185.
- Ensure you have all necessary tools before proceeding.
- Do not attempt to work on your vehicle when the engine is hot.

NOTE: Retain factory parts for future use.

| Label | Qty. | Description | Part Number |
|-------|------|--------------------------|----------------------------------|
| A1 | 2 | Air Filter (Pro DRY S) | 21-30003 |
| A2 | 2 | Air Filter (Pro 5R) | 24-30003 |
| B1 | 1 | Tube #1 of 2 | 05-22642B1 |
| B2 | 1 | Tube #2 of 2 | 05-22642B2 |
| C | 1 | Housing | 05-12972B3 |
| D | 1 | Coupling, Silicone Elbow | 05-01445 |
| E | 1 | Coupling, Silicone Elbow | 05-01446 |
| F | 3 | Clamp, #044 | 03-50019 |
| G | 2 | Clamp, Mini, #010 | 03-50078 |
| H | 1 | Vent Insert | 05-01405 (For V6-3.5L (tt) only) |
| I | 1 | Hose, Fuel: 5/8"ID (2") | 05-00069 |
| J | 1 | Seal, Trim: 7/16" (26") | 05-00072 |
| K | 1 | Clamp, #064 | 03-50006 |

Installation will require the following tools:

8mm Nut Driver, Flat Head Screwdriver

Warranty Information available at: <https://afepower.com/contact#warranty>

Note: Legal in California for use on race vehicles only. The use of this device on vehicles used on public streets or highways is strictly prohibited in California and others states that have adopted California emission regulations.

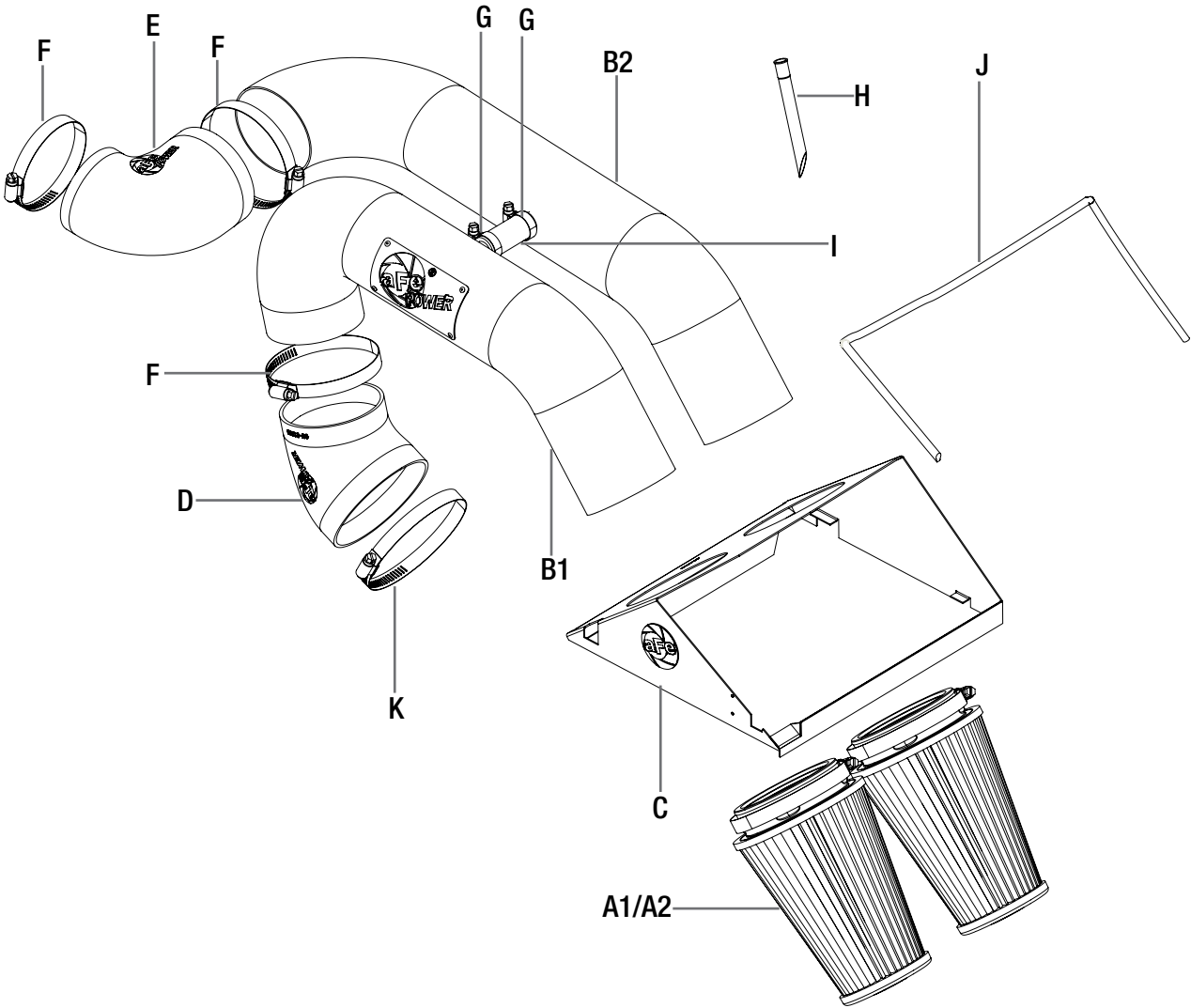



Figure A

Refer to Figure A for Steps 1-4.

Step 1: Disconnect the Temperature sensor plug from stock tube. ①

Step 2: Loosen the OE intake clamps using an 8mm nut driver from the left and right side runners. ②

Step 3: Unclamp the top portion of the OE airbox. ③

Step 4: Remove the OE intake and the top portion of the OE airbox by pulling straight up and out of the vehicle.



Figure B

Refer to Figure B for Step 5.

Step 5: Install trim seal onto the air filter housing.

**Figure C****Refer to Figure C for Steps 6-9.**

Step 6: Remove the sensor from the OE intake ¼ turn counter clockwise.

Step 7: Install the sensor into the rear aFe intake tube.

Step 8: Install housing and retain with the factory clips.

Step 9: Install filters from inside the housing. Make sure they are inserted flush and filter retention bumps hold them in place.



Figure D

Refer to Figure D for Steps 10-12.

Step 10: Install the small 5/8 x 3" hose on the crossover tube with the appropriate clamps, but do not tighten.

Step 11: Fit tubes into the remaining couplers. Adjust for best fit and tighten all clamps.

Step 12: Connect sensor harness to the Temp Sensor.

Vent insert installation:

INSTALL



Refer to Figure E for Step 13. (For V6-3.5L (tt) only, not necessary on V6-2.7L (tt))

NOTE: (These procedures should be done with the inlet tubes installed on the engine. It is shown off the vehicle for better illustration.)

Step 13: Locate the o.e. plastic tube feeding the driver's side turbo inlet.



Figure F

Refer to Figure F for Step 14. (For V6-3.5L (tt) only, not necessary on V6-2.7L (tt))

Step 14: Locate the valve cover vent tube that feeds into driver's side turbo inlet. It is not necessary to remove the engine cover.

**Figure G**

Refer to Figure G for Step 15. (For V6-3.5L (tt) only, not necessary on V6-2.7L (tt))

Step 15: Note the release clip on the vent tube connectors. Apply pressure against the exposed tail and pull vent fitting off of the turbo inlet tube. It is not necessary to disconnect at the valve cover end. There is a sensor and wire harness on this vent tube. Do not damage or remove these components.



Figure H

Refer to Figure H for Step 16. (For V6-3.5L (tt) only, not necessary on V6-2.7L (tt))

Step 16: Insert vent fitting with slash cut facing turbo inlet. It should not be a loose fit. It is direction dependent and must not rotate once installed.

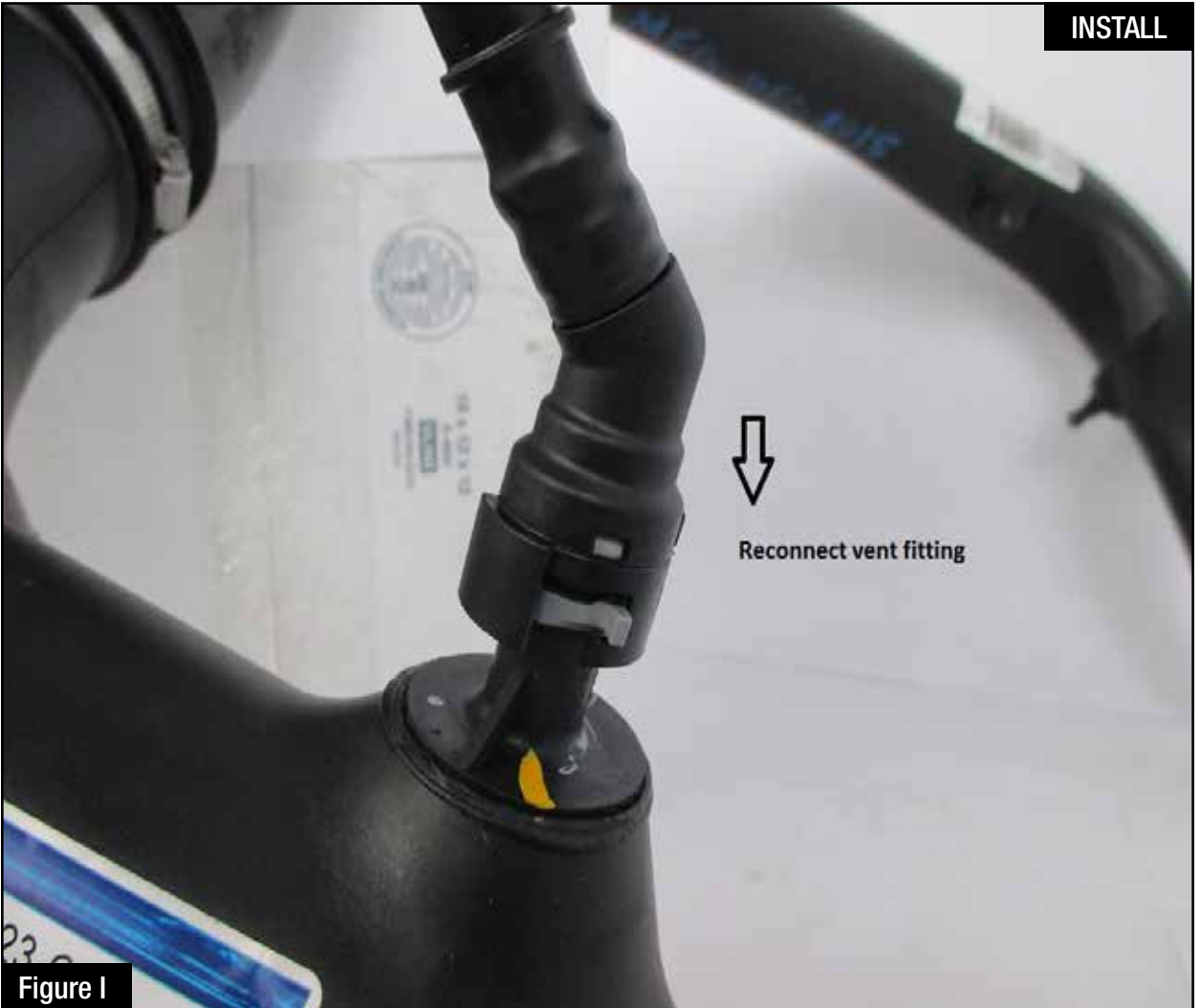

Refer to Figure I for Steps 17-18. (For V6-3.5L (tt) only, not necessary on V6-2.7L (tt))

Step 17: Reconnect the vent fitting. It will snap over without having to release the plastic clip. Pull up slightly to confirm installation.

Step 18: Installation is complete. Any codes can be cleared with a code reader or by disconnecting the battery. You will lose any radio presets with battery disconnection.

NOTE: If removal of the vent insert is required, it can be pulled out with internal snap ring pliers.



Figure J

Refer to Figure J for Step 19.

Step 19: Make sure all clamps and screws are tight. Your installation is now complete.

NOTE: Check all bolts, clamps, and connectors after 100-200 miles.



PAGE LEFT BLANK INTENTIONALLY

PAGE LEFT BLANK INTENTIONALLY



advanced FLOW engineering, inc.
252 Granite Street Corona, CA 92879
TEL: 951.493.7100 • TECH: 951.493.7134
E-Mail: Tech@aFepower.com