

advanced FLOW engineering

Instruction Manual P/N: 54-82202 & 51-82202

Make: **BMW** Model: **335i (F30)** Year: **2012-2015** Engine: **L6-3.0L (Turbo) N55**



- Please read the entire instruction manual before proceeding.
- Ensure all components listed are present.
- If you are missing any of the components, call customer support at 951-493-7100.
- Ensure you have all necessary tools before proceeding.
- Do not attempt to work on your vehicle when the engine is hot.
- Retain factory parts for future use.

Label	Qty.	Description	Part Number
A1	1	Air Filter (Pro 5R)	24-91063
A2	1	Air Filter (Pro DRY S)	21-91063
B	1	Tube	05-82202B1
C	1	Housing	05-82202B2
D	2	Screw, M4	03-50221
E	1	Clamp, 096	03-50003
F	1	Grommet	03-50033
G	1	Cap: 1/2"	03-50103
H	1	Fitting, Vacuum line	05-01246
I	1	Torx Bit	03-50066

Installation will require the following tools:
Phillips screw driver & 8mm nut driver.

Warranty Information available at <https://afepower.com/contact#warranty>

Note: Legal in California for use on race vehicles only. The use of this device on vehicles used on public streets or highways is strictly prohibited in California and others states that have adopted California emission regulations.

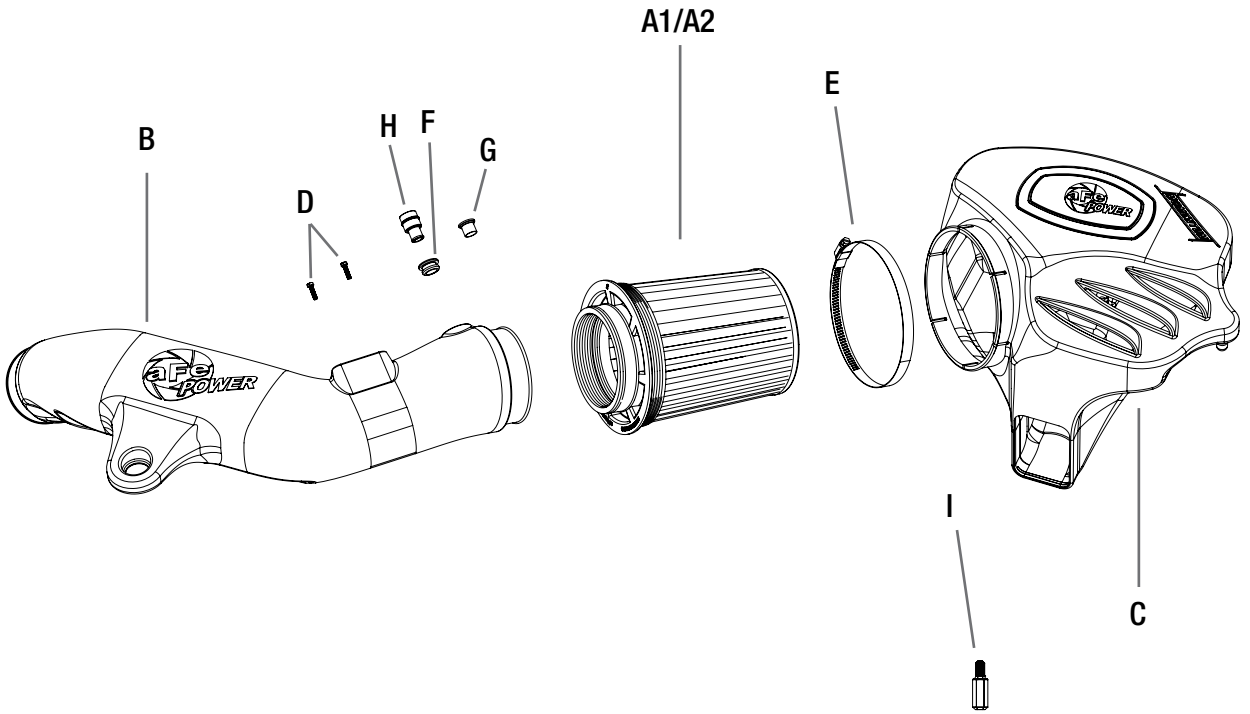

* Installation video available on aFe's Youtube Channel

**Refer to Figure A for step 1-3**

Step 1: Disconnect MAF sensor harness ①.

Step 2: Unplug the vacuum line ② (Automatic vehicle only)

Step 3: Loosen the clamp on the factory intake tube ③.

Step 4: Remove your factory intake system out of the vehicle by pulling it off the mounting grommets.



Figure B

Refer to Figure B for steps 5-7

- Step 5: Remove the MAF sensor off the factory intake tube using the furnished T20 torx bit and install onto the aFe intake tube with the furnished screws (4) .
- Step 6: Remove the OE grommet off the intake tube and install onto the aFe intake tube (5) .
- Step 7: For vehicles with an automatic transmission, install the provided grommet and aluminum fitting into the hole of the aFe intake tube. For vehicles with a manual trasmission, simply cap off the hole with the grommet and plug provided (6) .

**Figure C****Refer to Figure C for step 8**

Step 8: Slide the aFe filter into the housing and install the clamps. Tighten the large clamp on the housing using a nut driver.

(Note: Wipe clean the air filter flange and housing flange before installation)

**Figure D****Refer to Figure D for steps 9-10**

Step 9: Install the aFe housing into the vehicle by pushing it into the factory grommets (7).

Step 10: Slide the aFe intake tube into the factory inlet tube and into the aFe filter. Then, push the tube into the mounting location (8).

**Figure E****Refer to Figure E for steps 11-12**

Step 11: Lift up the engine cover and re-route the MAF harness around the oil filter housing and re-connect it to the MAF sensor (9).

Step 12: Re-connect the vacuum line to the aluminum fitting (10) (Automatic vehicle only).

Step 13: Tighten all clamps and pull film off the plastic sight window.

Step 14: Verify all clamps are secure and re-check periodically. Your Installation is now complete.

Note: The Housing has a location on the back of the air box to mount the aFe electronic module (P/N 77-46304)

Page left blank intentionally

Page left blank intentionally

Page left blank intentionally

advanced FLOW engineering, inc.