

**GT**  
**MOMENTUM™**

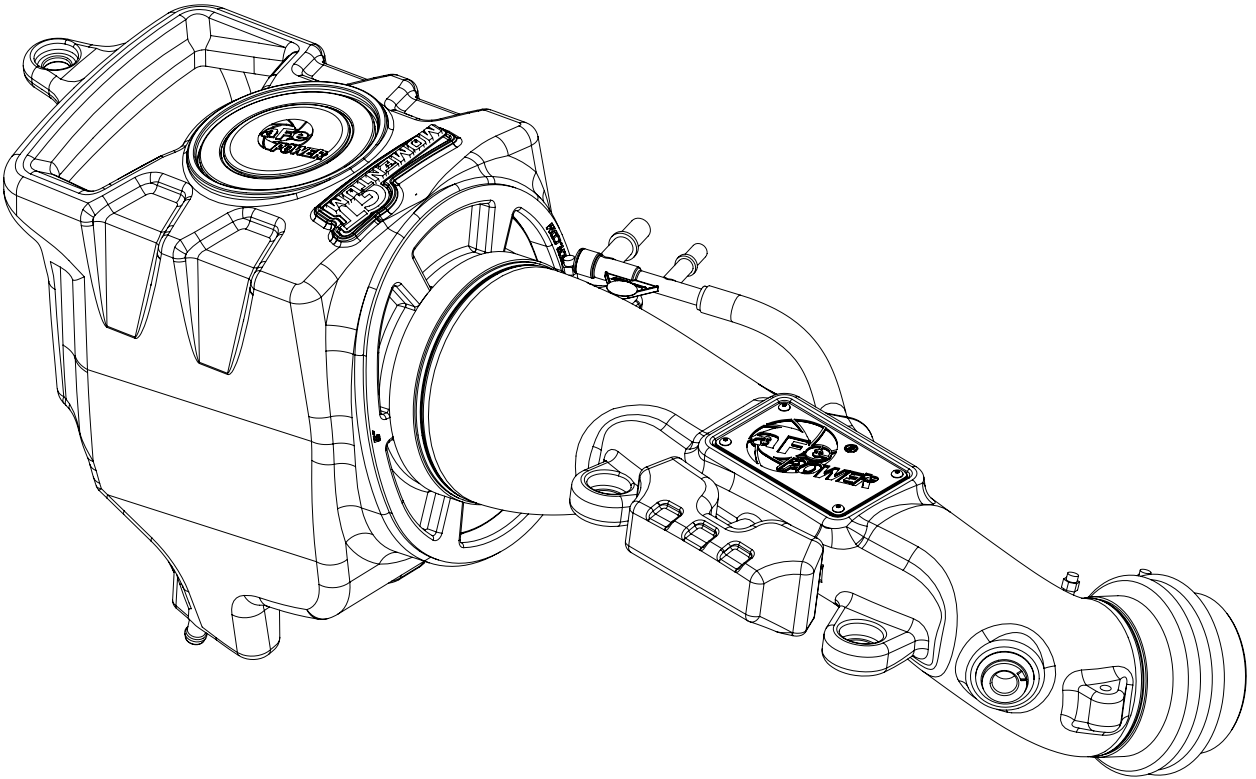

**advanced FLOW engineering** Momentum GT Cold Air Intake System  
**Instruction Manual** P/N: 50-70035D / 50-70035R / 50-70035G

Make: **Jeep** Model: **Wrangler (JL)** Year: **2018-2020** Engine: **L4-2.0L Turbo**



- Please read the entire instruction manual before proceeding.
- Ensure all components listed are present.
- If you are missing any of the components, call customer support at 951-493-7185.
- Ensure you have all necessary tools before proceeding.
- Do not attempt to work on your vehicle when the engine is hot.
- Disconnect the negative battery terminal before proceeding.
- Retain factory parts for future use.

Label	Qty.	Description	Part Number
A1	1	Air Filter (Pro 5R)	24-91126
A2	1	Air Filter (Pro DRY S)	21-91126
A3	1	Air Filter (Pro-GUARD 7)	72-91126
B	1	Tube	05-5070035B1
C	1	Housing	05-76217B2
D	1	Coupling, Silicone Bellows	05-01480
E	2	Clamp, T-bolt (3-5/16" - 3-9/16")	03-50292
F	1	Fitting, CCV Vacuum	05-01499
G	1	Nipple, Brs. Hose: 3/8"ID	03-50193
H	1	Hose, Silicone Breather: 3/8"ID (7" inches)	05-01503
I	1	Retainer, Clip: 1/4" Hole	05-01350
J	1	Grommet, Rubber	03-50167
K	1	Fitting, Air Temp Sensor	05-01454

**Installation will require the following tools:**

8mm nut driver or flat head screwdriver, 10mm socket and driver, 11mm deep socket or nut driver, panel popper tool, 9/16" wrench or adjustable wrench, and needle nose pliers.

**Emissions Disclaimer:**

This product is not currently CARB exempt and is not available for purchase in California or for use on any vehicle registered with the California Department of Motor Vehicles.

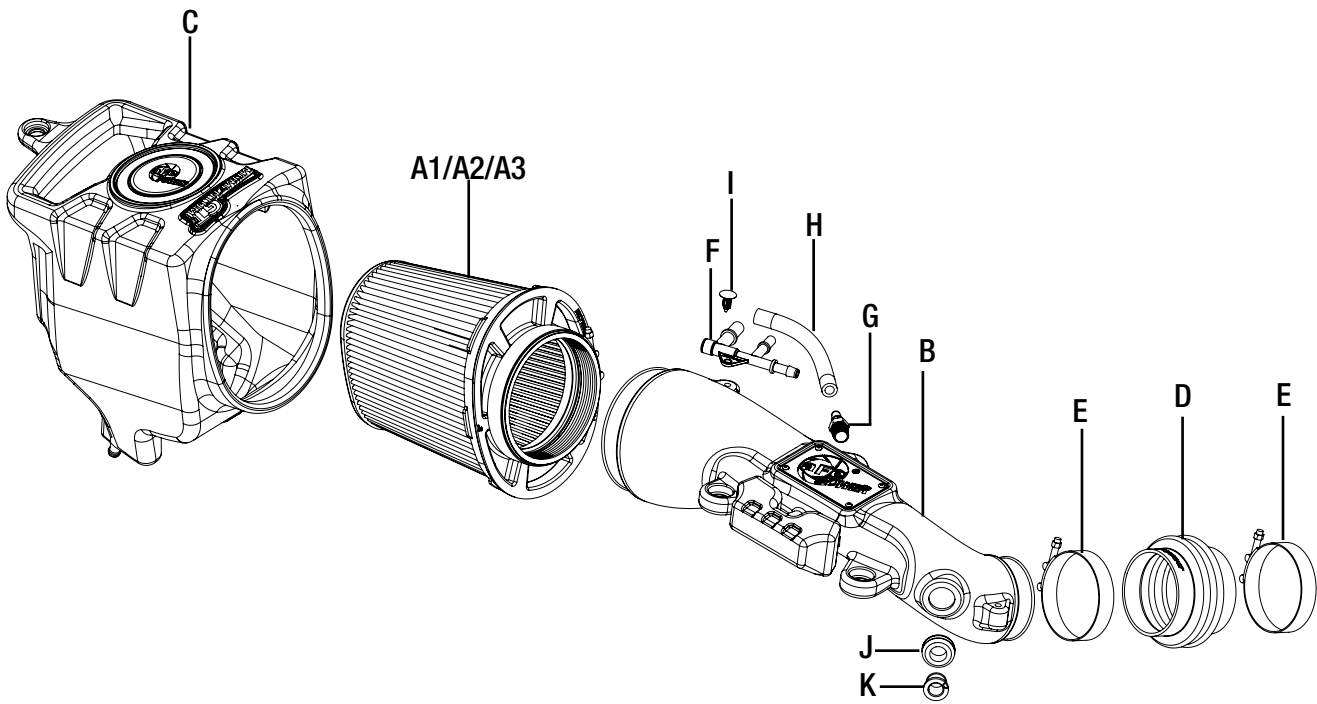

**Figure A****Refer to Figure A for Steps 1-2**

Step 1: Using a 10mm socket and driver, remove the three screws (1) securing the factory intake to the vehicle.

Step 2: Using an 8mm nut driver, loosen the two clamps (2) on the intake tube.



Figure B

**Refer to Figure B for Steps 3-5**

Step 3: Disconnect the two vent lines that are connected to the vacuum generator (3) by pushing on the grey clips and sliding the tubes off the fittings.

Step 4: Disconnect the Intake Air Temperature (IAT) sensor (4).

Step 5: Remove the attaching clips for the IAT sensor harness (5) and move the harness out of the way for now.

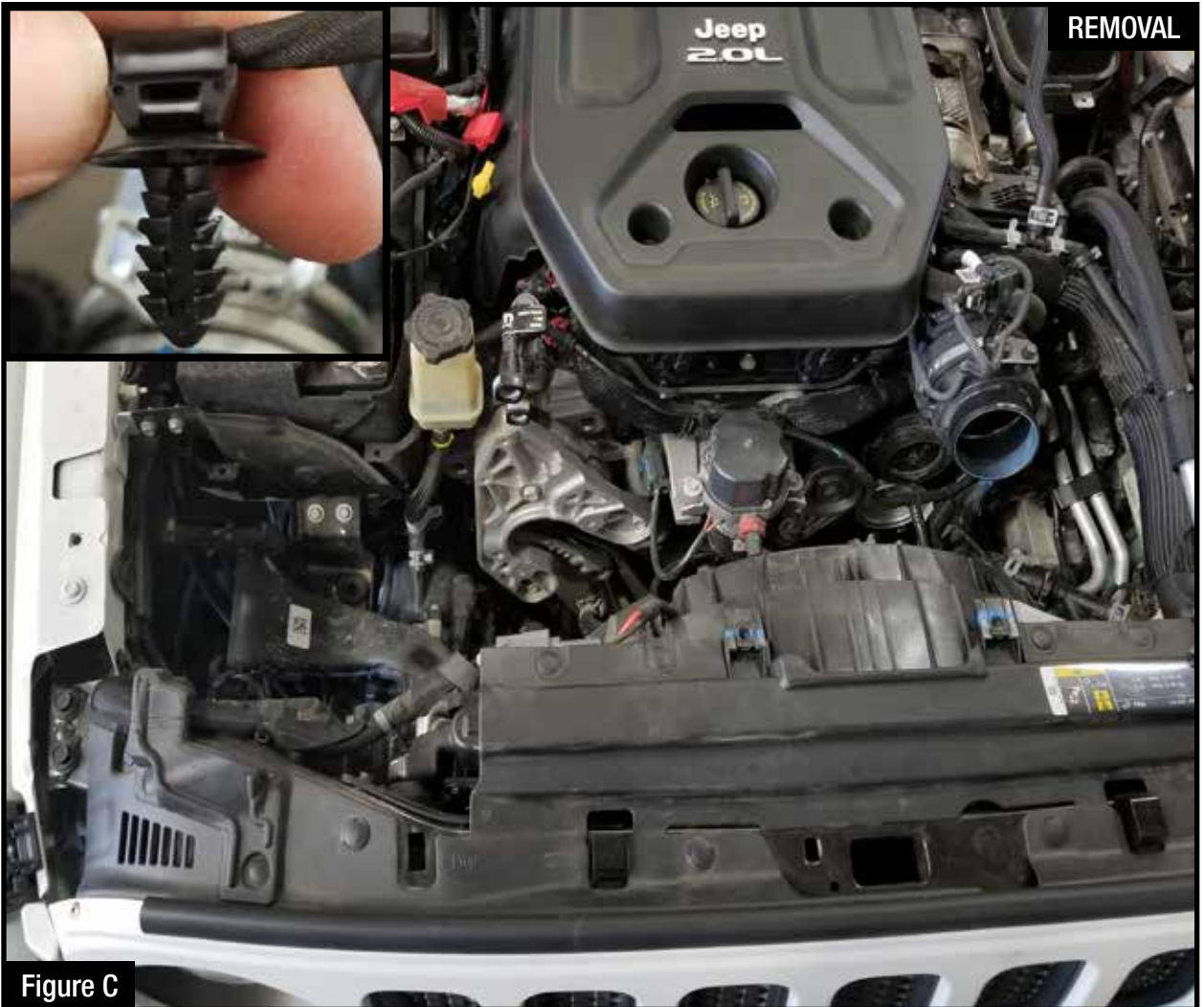

Figure C

**Refer to Figure C for Steps 6-8**

Step 6: Remove the factory intake tube from the vehicle.

Step 7: Remove the factory housing from the vehicle by lifting straight upward. If the rubber grommets pop off with the housing, then remove them from the housing and place them back into the holes in the mounting bracket.

Step 8: If the attaching clips on the IAT sensor harness and the coolant line are bent out of shape, then repair them so that they look like the clip shown in the small photo.



Figure D

**Refer to Figure D for Steps 9-10**

Step 9: Using a 9/16" wrench or adjustable wrench, install the supplied brass barbed fitting (6) into the aFe POWER intake tube.

Step 10: Attach the new silicone hose to the barbed fitting and the plastic CCV fitting (7) as shown. Secure the CCV fitting with the provided push clip (8).



Figure E

**Refer to Figure E for Steps 11-12**

- Step 11: Install the grommet and temp sensor adaptor (9) into the hole on the front of the intake tube. Make sure that the bead on the adaptor is positioned correctly in the grommet so that it cannot pop out during use.
- Step 12: Carefully remove the IAT sensor (10) from the factory intake tube by lifting it up slightly on the plastic tab and rotating the sensor 1/4 turn counterclockwise.



Figure F

**Refer to Figure F for Steps 13-15**

- Step 13: Reinstall the IAT sensor (11) into the temp sensor adaptor on the aFe POWER intake tube and make sure to lock it into position by rotating it clockwise until the small tab clicks into place.
- Step 14: Remove the metal sleeves and rubber grommets (12) from the factory intake tube and reinstall them into the aFe POWER intake tube as shown.
- Step 15: Install the silicone coupler (13) and two t-bolt clamps as shown prior to installing the tube into the vehicle.



Figure G

**Refer to Figure G for Steps 16-18**

- Step 16: Remove the metal sleeve and rubber grommet ⑭ from the factory intake housing and reinstall them into the aFe POWER intake housing as shown.
- Step 17: Slide the filter into the aFe POWER housing until all of the tabs snap into place inside the housing.
- Step 18: Install the aFe POWER housing and filter assembly into the vehicle by lining up the pegs into the grommets and then pressing down firmly to lock them into place. Use one of the screws removed in Step 1 to secure the housing to the fender.



Figure H

**Refer to Figure H for Steps 19-21**

- Step 19: Insert the large end of the tube into the filter and then rotate the other end of the tube so that the coupler slides onto the turbo inlet tube.
- Step 20: Reconnect the IAT sensor harness to the IAT sensor (15) and secure the push clip on the harness into the hole on the tube.
- Step 21: Using the remaining two screws (16) removed in Step 1, secure the intake tube to the core support.

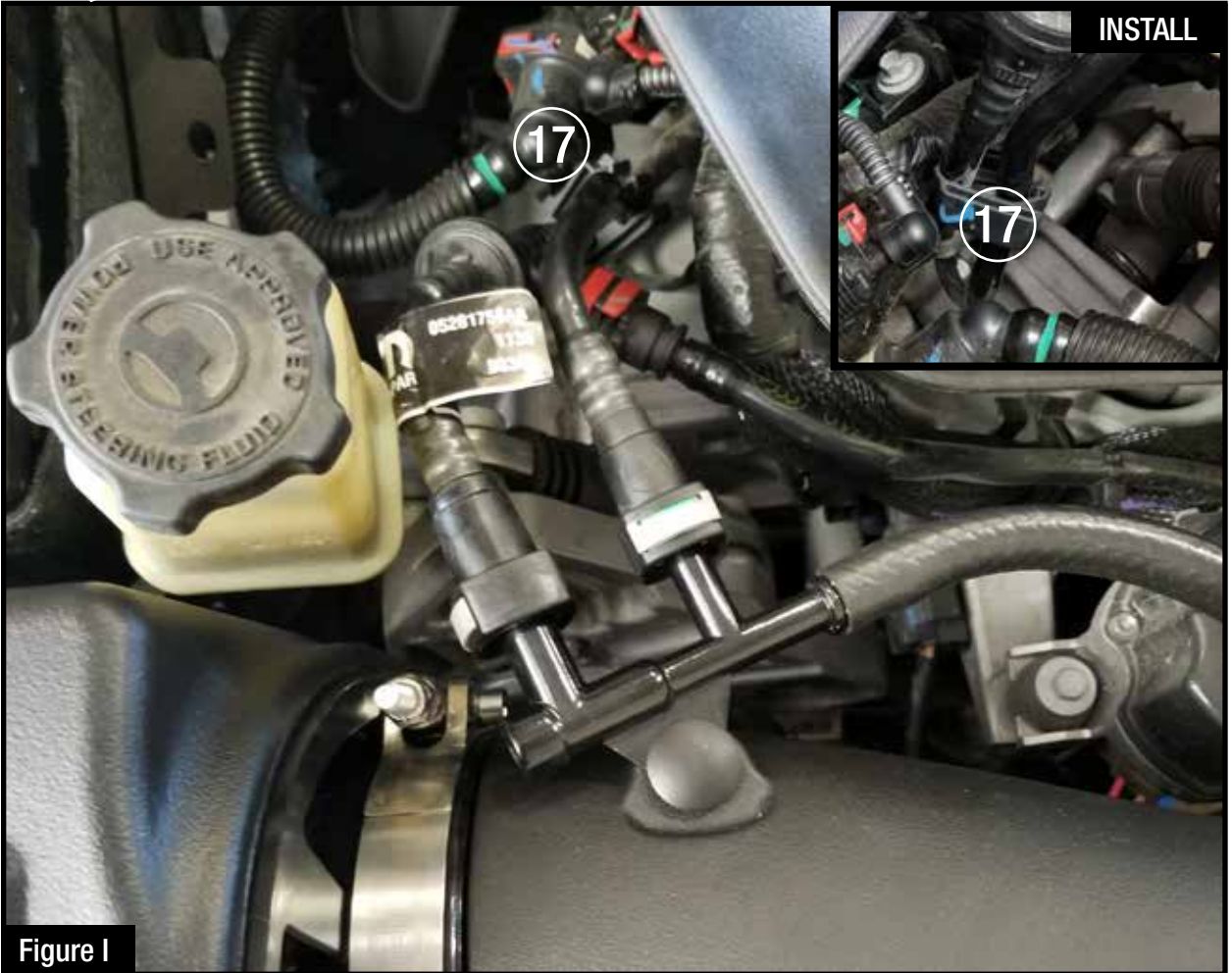

Figure I

**Refer to Figure I for Steps 22-25**

- Step 22: Locate and disconnect the clip that holds the two vent tubes together (17).
- Step 23: Situate the tube connectors so that they line up with their respective location on the new CCV fitting.
- Step 24: Push the connectors all the way onto the fitting until they both lock into place.
- Step 25: Reattach the clip near the same location in which it was removed so that the two tubes do not rest on each other.



Figure J

**Refer to Figure J for Steps 26-28**

Step 27: Tighten all three clamps using an 11mm nut driver or deep socket. Do not over tighten the clamps.

Step 28: Verify that all connectors are secure and the three screws are tightened properly.

Step 29: Your installation is now complete! Thank you for choosing aFe POWER!

**NOTE: Check all bolts, clamps, and connectors after 100-200 miles.**



Pro DRY S Air Filter



P/N: 21-91126

Pro 5R Air Filter



P/N: 24-91126

Pro-GUARD 7 Air Filter



P/N: 72-91126

Pre-Filter



P/N: 28-10283

Pro DRY S Restore Kit



P/N: 90-59999

Blue Squeeze Restore Kit



P/N: 90-50501

Gold Squeeze Restore Kit



P/N: 90-50500

SCORCHER GT Module



P/N: 77-46206

Cat-Back Exhaust System



P/N: 49-48079 (No Tip)

Rear Differential Cover



P/N: 46-71031B (w/ Oil)  
46-71000B (Blk./Mach.)

RaceRunner 2" Shocks



P/N: 37-D7001R (Rears)  
37-D7001F (Fronts)

Throttle Body Spacer



P/N: 46-35008

To purchase any of the items above, view airflow charts, dyno graphs, photos, and video; please go to [aFepower.com](http://aFepower.com).

# Warranty

## General Terms:

- aFe warrants their products to be free from manufacturer's defects due to workmanship and material.
- This warranty applies only to the original purchaser of the product and is nontransferable.
- Proof of purchase of the aFe product is required for all warranty claims.
- Warranty is valid provided aFe instructions for installation and/or cleaning were properly followed.
- Proper maintenance with regular inspections of product is required to insure warranty coverage.
- Damage due to improper installation, abuse, unauthorized repair or alteration is not warranted.
- Incidental or consequential damages or cost, including installation and removal of part, incurred due to failure of aFe product is not covered under this warranty.
- All warranty is limited to the repair and/or replacement of the aFe part. To request Return Goods Authorization ("RGA"), email [RGA@afepower.com](mailto:RGA@afepower.com) or call (951)493-7100. Upon receipt of the RGA, you must return the product to the address provided in the RGA, freight prepaid and accompanied with a dated proof of purchase and the RGA. Upon receipt of the defective product and upon verification of proof of purchase, aFe will either repair or replace the defective product within a reasonable time, not to exceed thirty days.

<b>Product Category</b>	<b>P/N Prefix</b>	<b>Warranty duration</b>
Direct OE Replacement Filters	10, 11, 30, 31, 71, 73	Life of the vehicle
Racing Filters	18	1 year
Universal	21, 23, 24, 72	2 years
Air Intake Systems	50, 51, 53, 54, 55, 56, 58, 75	2 years
Exhaust Systems	49	2 years
Intercoolers & Intercooler Tubes	46-2	2 years
Intake Manifolds	46-1	2 years
Differential Cover	46-7	Life of the vehicle
Exhaust Manifolds	46	2 years
Throttle Body Spacers	46-3	2 years
Fluid Filters	44	90 days
Pre-Filters	28	2 years
Heavy Duty OE Replacement	70	2 years
PowerSports OE Replacement	81, 87	2 years
PowerSports Intake Systems	85	2 years

No other warranty expressed or implied applies nor is any person or advanced FLOW engineering authorized to assume any other warranty. Some States do not allow the exclusion or limitation of incidental or consequential damages or do not allow limitations on how long an implied warranty lasts, so the above limitations or exclusions may not apply to you. This warranty gives you specific legal rights, and you may also have other rights which vary from State to State.

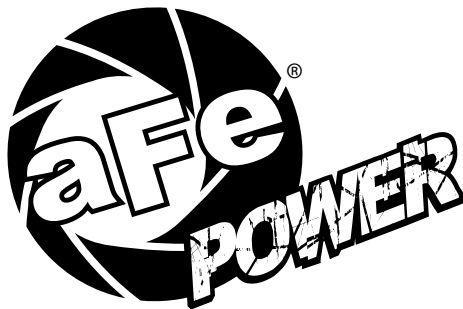

**advanced FLOW engineering, inc.**  
252 Granite Street Corona, CA 92879  
TEL: 951.493.7100 • TECH: 951.493.7185  
E-Mail: [Tech@aFepower.com](mailto:Tech@aFepower.com)