

advanced FLOW engineering Momentum GT Cold Air Intake System

Instruction Manual P/N: 50-70046R / 50-70046D

Make: SUZUKI

Model: JIMNY

Year: 2019-2023

Engine: L4-1.5L



- Please read the entire instruction manual before proceeding.
- Ensure all components listed are present.
- If you are missing any of the components, call customer support at 951-493-7185.
- Ensure you have all necessary tools before proceeding.
- Do not attempt to work on your vehicle when the engine is hot.
- Retain factory parts for future use.

Label	Qty.	Description	Part Number
A1	1	Air Filter (Pro 5R) For 50-70046R	24-91155
A2	1	Air Filter (Pro DRY S) For 50-70046D	21-91155
B	1	Tube, Silicone	05-5070046B1
C	1	Housing, Plastic	05-5070046B2
D	1	Inlet Scoop, Plastic	05-5070046B3
E	1	Coupling, Silicone: 3-3/4"ID x 3"L	05-01509
F	1	Clamp, 032 (1-9/16" -2-1/2")	03-50016
G	2	Clamp, 060 (3-5/16" - 4-1/4")	03-50002

Installation will require the following tools:

8mm & 10mm nut drivers or ratchet and sockets, pliers or flat-head screwdriver

Warranty Information available at: <https://afepower.com/contact#warranty>

Emissions Disclaimer: This product does not require a CARB EO# (Vehicle does not exist in U.S.)

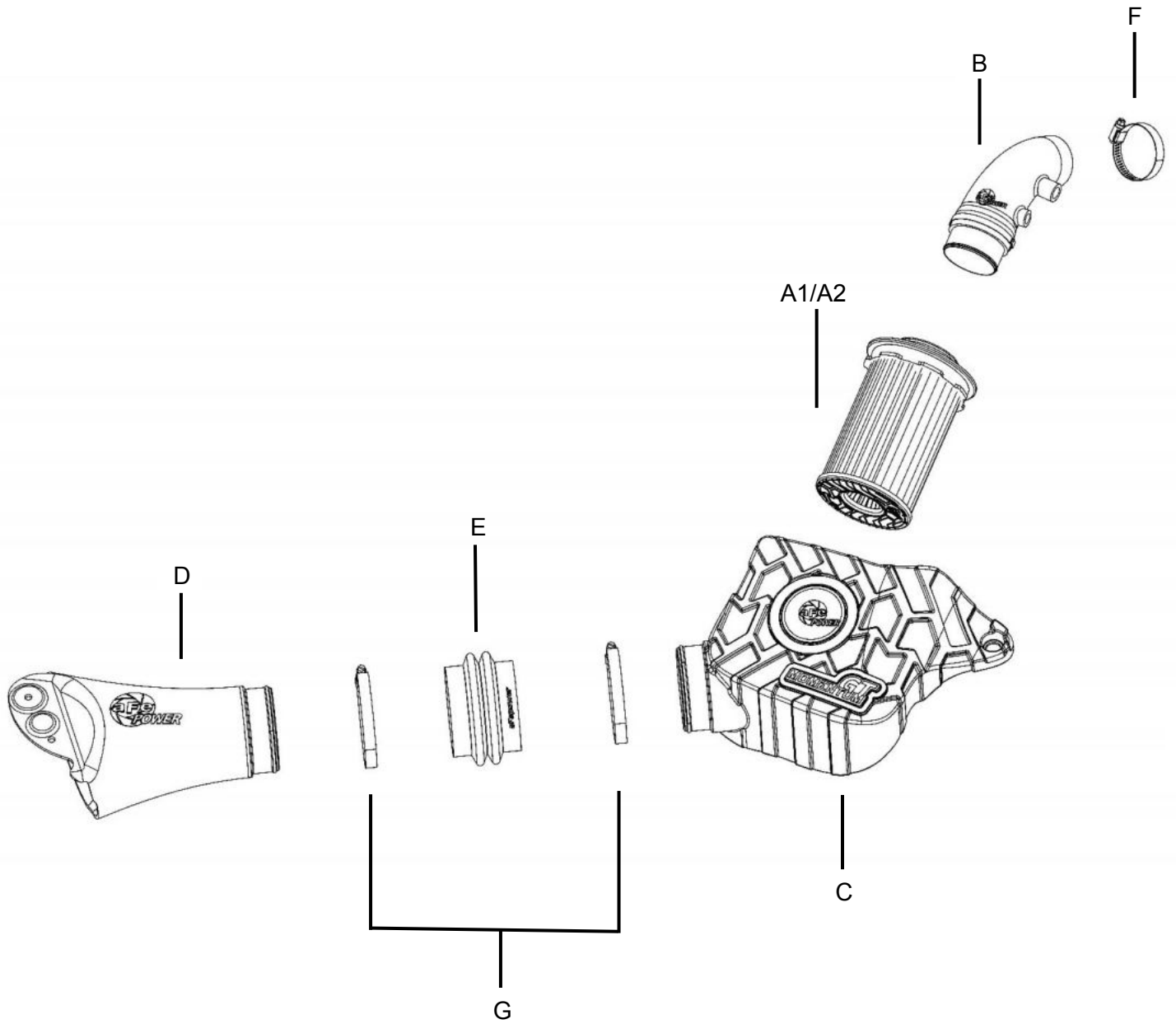

**Figure A****Refer to Figure A for Steps 1-2**

Step 1: Remove the two screws securing the inlet scoop. Those screws will be reused to secure the aFe POWER scoop.

Step 2: Remove the screw securing the factory housing to the engine. This screw will be reused to secure the aFe POWER housing.

**Figure B****Refer to Figure B for Steps 3-5**

Step 3: Remove the second screw securing the factory housing to the mounting bracket. This screw will also be reused to secure the aFe POWER housing.

Step 4: Using pliers, unclip the harness from the factory housing.

Step 5: Untighten the clamp securing the factory intake tube to the throttle body.



Figure C

Refer to Figure C for Steps 6-7

Step 6: Disconnect the harness from the temperature sensor on the factory intake tube.

Step 7: Pull the metal tube out of the factory intake tube.



Figure D

Refer to Figure D for Steps 8-9

Step 8: Remove the full factory air intake system as one piece by pulling the factory intake tube off the throttle body and the factory housing off its grommet.

Step 9: Make sure the grommet under the housing stays in position. This mount will be reused for the aFe POWER housing.

**Figure E****Refer to Figure E for Steps 10-11**

Step 10: Transfer the two grommets with metal sleeves from the factory housing to the aFe POWER Housing.

Step 11: Slide the aFe POWER air filter into the aFe POWER housing and push it in until it locks into place. Install the clamp on the filter, but do not tighten the clamp at this time.



Figure F

Refer to Figure F for Step 12

Step 12: Remove the temperature sensor from the factory tube and install it into the aFe POWER tube.

**Figure G****Refer to Figure G for Steps 13-14**

Step 13: Connect the aFe POWER tube to the filter.

Step 14: Install the smaller clamp on the aFe POWER tube end, and the filter clamp on the filter end but do not tighten at this time.



Figure H

Refer to Figure H for Steps 15-16

Step 15: Install the aFe POWER housing and tube assembly in the vehicle. Slide the tube over the throttle body then press the housing peg into the grommet from steps 8 and 9.

Step 16: Align the tube, filter, and housing then press the metal tube into the aFe POWER tube.



Figure I

Refer to Figure I for Steps 17-19

Step 17: Secure the aFe POWER housing using the factory screws removed at step 2 and 3.

Step 18: Tighten all clamps.

Step 19: Reconnect the harness to the temperature sensor.



Figure J

Refer to Figure J for Steps 20-21

Step 20: Install the bellow coupling onto the opening of the aFe POWER housing.

Step 21: Place the clamps on the coupling but do not tighten yet.



Figure K

Refer to Figure K for Steps 22-24

Step 22: Install the aFe POWER scoop into the bellow coupling.

Step 23: Secure the scoop to the fender using the two screws removed at step 1.

Step 24: Tighten all clamps.

**Figure L****Refer to Figure L for Step 25**

Step 25: Verify all clamps and connections are secured. Your installation is now complete. Thank you for choosing aFe POWER!



advanced FLOW engineering, Inc.

252 Granite Street Corona, CA 92879

<https://afepower.com/contact>