

GT
MOMENTUM™

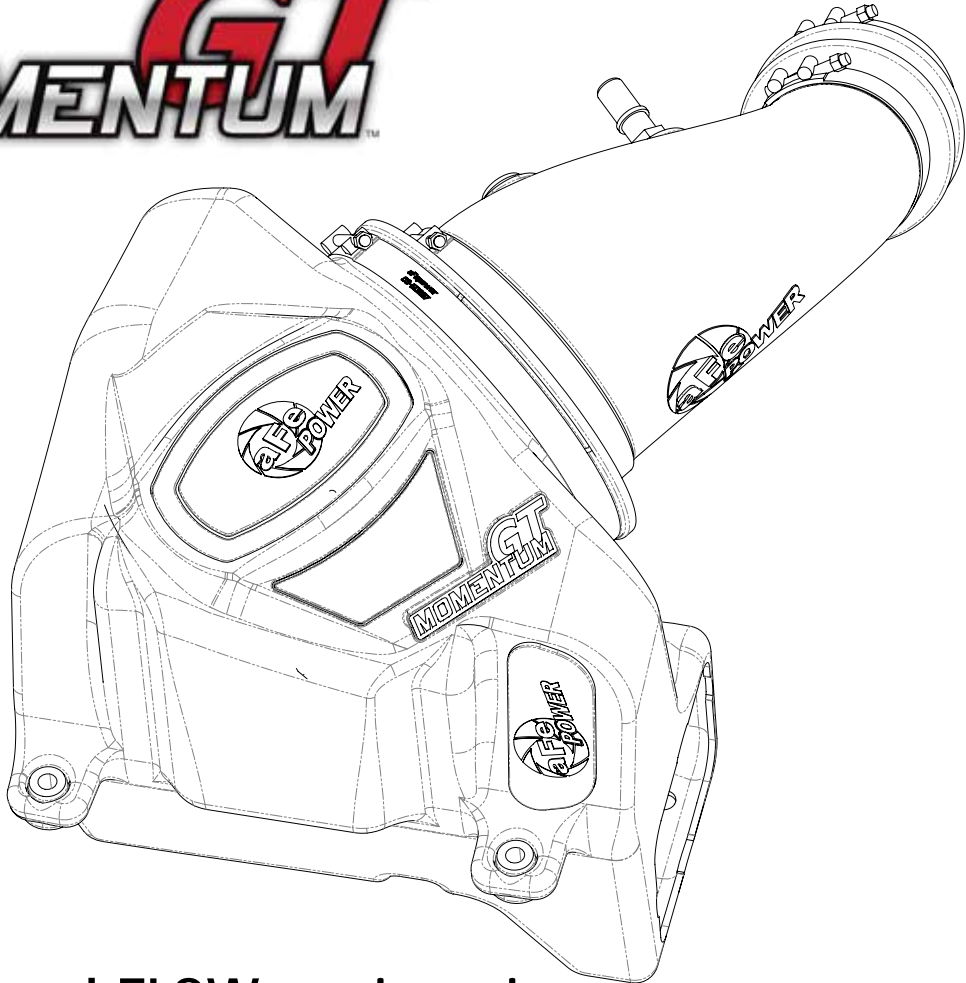

advanced FLOW engineering

Momentum GT Air Intake System

Instruction Manual P/N: 51-72104 / 54-72104 / 75-72104

Make: **RAM** Model: **2500/3500/Power Wagon** Year: **2017-2018** Engine: **V8-6.4L HEMI**



- Please read the entire instruction manual before proceeding.
- Ensure all components listed are present.
- If you are missing any of the components, call customer support at 951-493-7100.
- Ensure you have all necessary tools before proceeding.
- Do not attempt to work on your vehicle when the engine is hot.
- Disconnect the negative battery terminal before proceeding.
- Retain factory parts for future use.

Label	Qty.	Description	Part Number
A1	1	Air Filter (Pro 5R)	24-91110
A2	1	Air Filter (Pro DRY S)	21-91110
A3	1	Air Filter (Pro-GUARD 7)	72-91110
B	1	Tube	05-72104B1
C	1	Housing	05-72103B2
D	1	Plug, Airbox	05-00937
E	1	Clamp, T-Bolt (8-5/16" - 8-5/8")	03-50267
F	1	Screw, Hex Hd: M6	03-50032
G	1	Washer, Flat: M6	03-50070
H	1	Washer, Lock: M6	03-50071
I	2	Grommet, Urethane	03-50537
J	1	Fitting, Vent Large	05-01339
K	1	Threadlocker	03-50162
L	1	Grommet, Rubber	03-50167
M	1	Fitting, Air Temp Sensor	05-01454
N	1	Coupling, Silicone Hump	05-01389
O	2	Clamp, T-bolt (3-9/16" - 3-7/8")	03-50498

Tools Needed: 8mm nut driver or flat head screwdriver, 10mm socket and driver, 11mm nut driver or deep socket and driver, panel poppers or pliers.

Warranty Information available at: <https://afepower.com/contact#warranty>

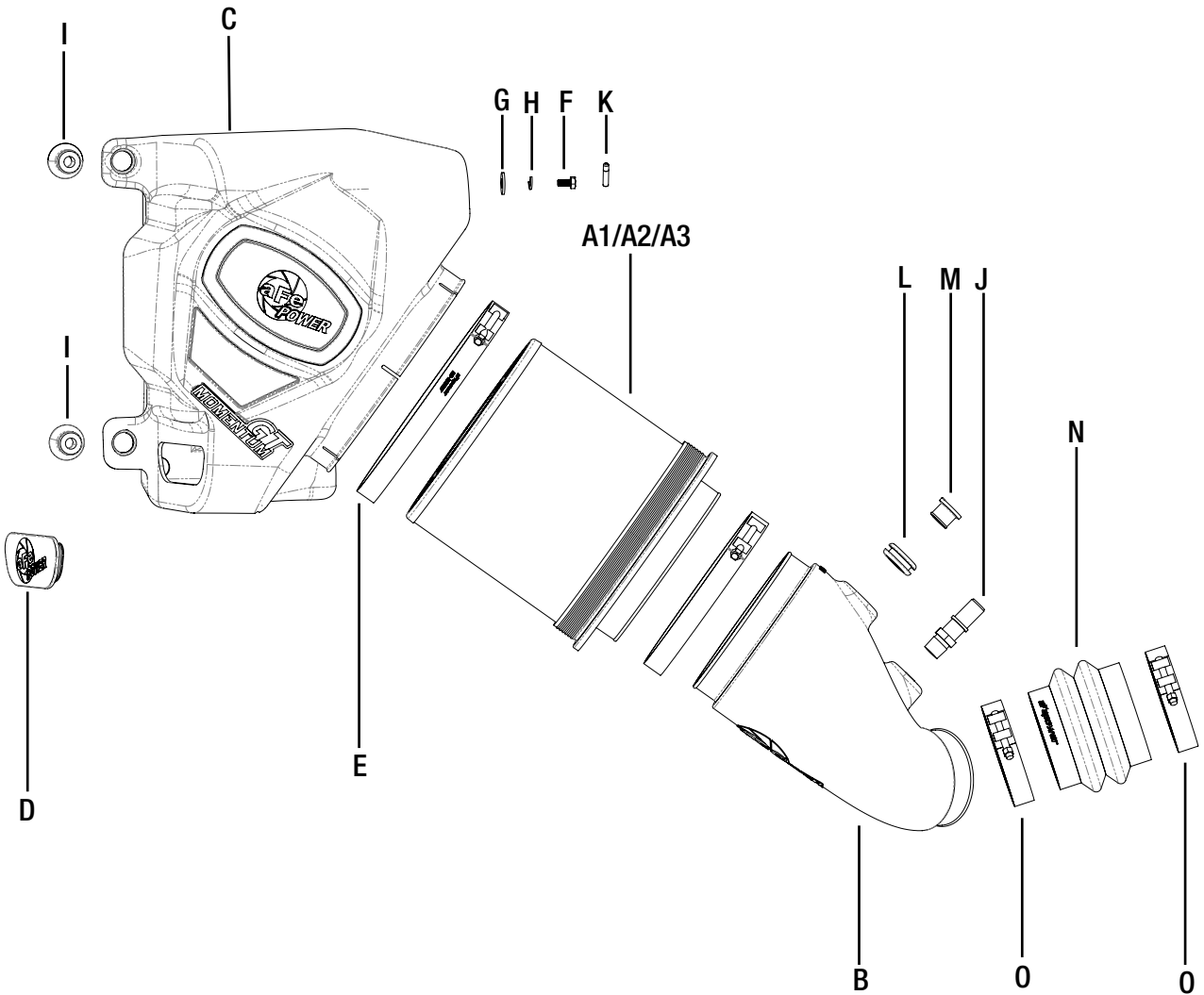

**Figure A****Refer to Figure A for Step 1**

Step 1: Remove the engine cover by lifting on front of the cover to release the front mounting points and then pulling straight forward towards the front of the truck to unclip the rear mounting points.



Figure B

Refer to Figure B for Steps 2-5

Step 2: Disconnect the temperature sensor.

Step 3: Disconnect the Crank Case Vent (CCV) hose from the intake tube by holding down on the connector and then pulling it straight off.

Step 4: Loosen the two clamps on the intake tube using an 8mm nut driver or slotted screw driver.

Step 5: Remove the intake tube from the vehicle.

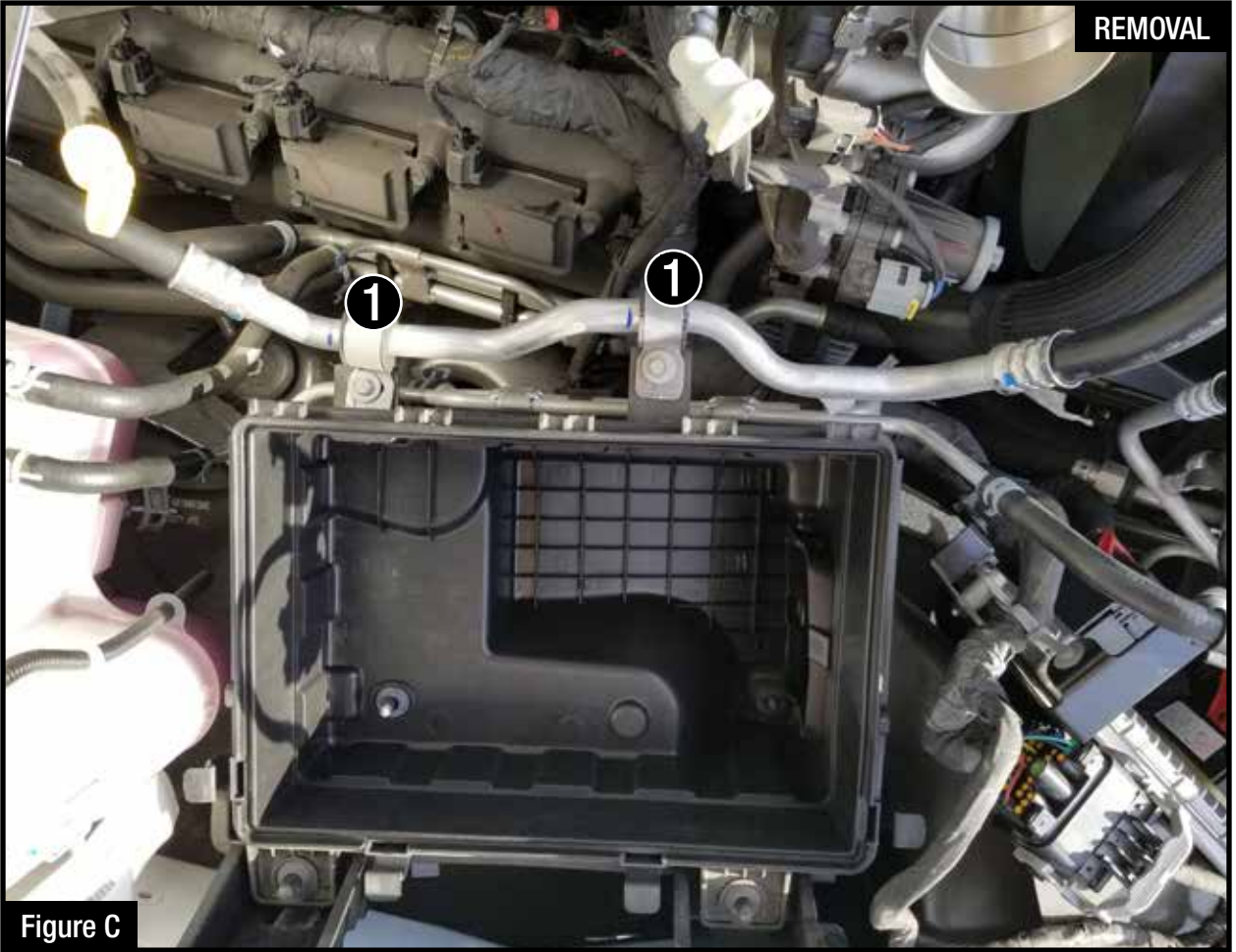
**Figure C****Refer to Figure C for Steps 6-9**

Step 6: Unclip the top half of the airbox and remove it.

Step 7: Remove the air filter from the airbox.

Step 8: Remove the two screws from the housing that secure the AC line using a 10mm socket and driver. ①

Step 9: Unclip the second set of hard lines and coolant line from the housing with a pair of pliers or a panel popper tool.

**Figure D****Refer to Figure D for Steps 10-12**

- Step 10: Pull straight up on the housing to remove it from its posts, but do not try to remove it all the way yet.
- Step 11: With the airbox still in the vehicle, disconnect the air duct from housing by pushing inward on the tabs.
- Step 12: Remove the intake housing and air duct from the vehicle.



Figure E

Refer to Figure E for Step 13

Step 13: Remove one of the isolation mounts from the AC line.



Figure F

Refer to Figure F for Steps 14-16

Step 14: Remove two of the rubber grommets from the bottom of the factory airbox.

Step 15: Transfer two of the rubber grommets to the bottom of the new aFe airbox. ②

Step 16: Install the two supplied urethane grommets into the tabs on the side of the aFe airbox. ③



Figure G

Refer to Figure G for Step 17

Step 17: Connect the factory air duct to the new aFe airbox as shown.

**Figure H****Refer to Figure H for Steps 18-22**

Step 18: Install the rubber grommet into the intake tube.

Step 19: Install the billet temperature sensor adaptor into the grommet.

Note: Use a lubricant or silicone spray to make this step easier.

Step 20: Put the supplied thread locker on the last 2-4 threads of the CCV adaptor.

Step 21: Install the CCV adaptor into the intake tube and tighten it up.

Note: This is an NPT fitting so please be sure not to over tighten this fitting. There will still be a gap between the tube and the hex part of the fitting after proper installation.

Step 22: Remove the temperature sensor from the factory intake tube and install it into the fitting on the new aFe intake tube.



Figure I

Refer to Figure I for Steps 23-25

- Step 23: Install the new aFe airbox into the vehicle by aligning the air duct back into its location and then align the four grommets on their posts.
- Step 24: Once the housing is in place, slide the isolation mount on the AC line over so that it is aligned with the threaded insert on the back of the airbox.
- Step 25: Use the M6 bolt, lock washer and flat washer provided to secure the isolation mount to the back of the airbox. Tighten the bolt with a 10mm socket and driver.



Figure J

Refer to Figure J for Steps 26-27

Step 26: Install the large clamp around the flange on the aFe airbox.

Step 27: Install the new aFe air filter into the airbox and make sure to leave both clamps loose.



Refer to Figure K for Step 28

Step 28: Install the coupling and two smaller clamps onto the throttle body as shown, but leave both clamps loose at this time.



Figure L

Refer to Figure L for Steps 29-31

- Step 29: Install the intake tube into the vehicle, but when doing so, align the CCV tube over the billet adaptor. It is not necessary to connect it all the way at this point but it makes the next step easier.
- Step 30: Align the tube so there is not a gap anywhere between the end of the tube and the back side of the filter flange.
- Step 31: Tighten all the clamps at this time, but make sure the smaller clamps will clear the engine cover after it is installed. (set the engine cover in the vehicle to test this if necessary)

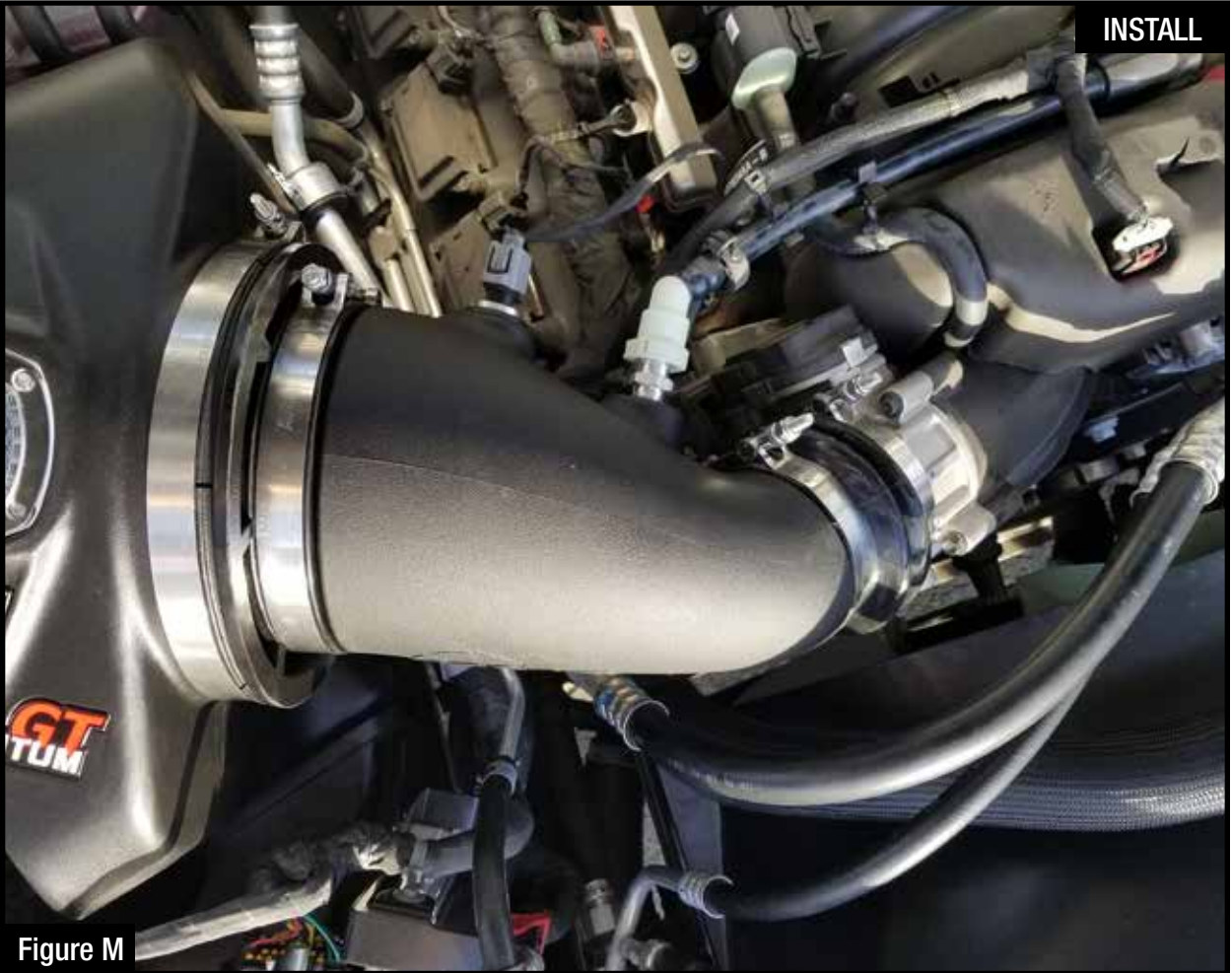

Refer to Figure M for Steps 32-33

Step 32: Reconnect the temperature sensor connector.

Step 33: Reconnect the CCV hose to the new adaptor and make sure that it clicks over the small step on the adaptor. Pull on the hose to make sure that it is securely fastened.



Figure N

Refer to Figure N for Steps 34-36

Step 34: Reinstall the engine cover by clipping the cover into the back mounting points and then pressing down firmly on the front mounting points.

Step 35: If you would like to install the provided plug for the airbox, then it can be installed now.

Step 36: Your installation is now completed.

NOTE: Check all bolts, clamps and connectors after 100-200 miles.



PAGE LEFT BLANK INTENTIONALLY

PAGE LEFT BLANK INTENTIONALLY

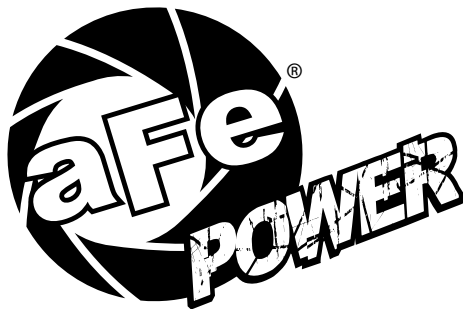

advanced FLOW engineering, inc.
252 Granite Street Corona, CA 92879
TEL: 951.493.7155 • TECH: 951.493.7100
E-Mail: Tech@aFepower.com