

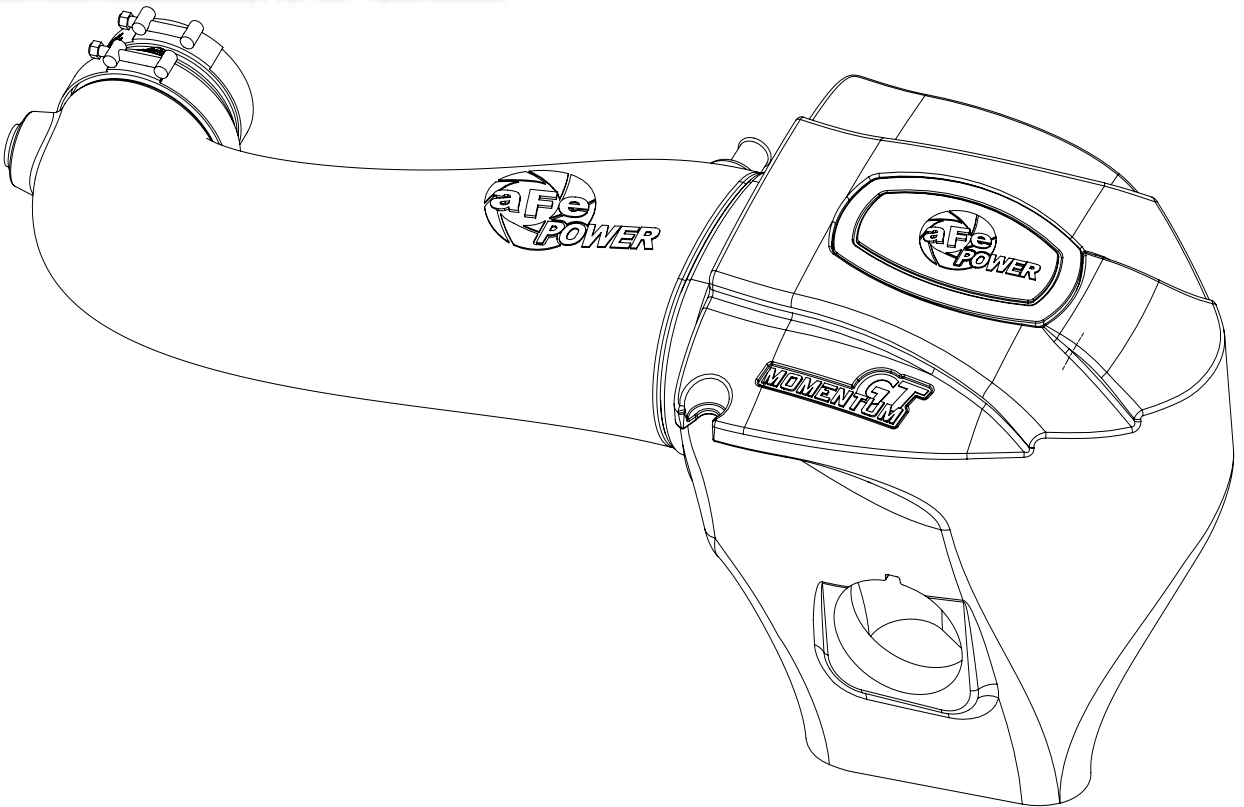

GT
MOMENTUM™



advanced FLOW engineering

Cold Air Intake System

Instruction Manual P/N: 51-72202 / 54-72202

Make: Chrysler **Model:** 300

Year: 2011-2014

Engine: V8-5.7L HEMI

Make: Dodge **Model:** Challenger

Year: 2011-2023

Engine: V8-5.7L HEMI

Make: Dodge **Model:** Charger

Year: 2011-2023

Engine: V8-5.7L HEMI



- Please read the entire instruction manual before proceeding.
- Ensure all components listed are present.
- If you are missing any of the components, call customer support at 951-493-7185.
- Ensure you have all necessary tools before proceeding.
- Do not attempt to work on your vehicle when the engine is hot.
- Retain factory parts for future use.

Label	Qty.	Description	Part Number
A1	1	Air Filter (Pro DRY S)	21-91092 (Grey Media)
A2	1	Air Filter (Pro-5R)	24-91092 (Blue Media)
B	1	Tube	05-72202B1
C	1	Housing	05-72201B2
D	1	Clamp, T-Bolt (3-3/4"-4-1/16")	03-50265
E	1	Clamp, T-Bolt (4-1/8"-4-1/2")	03-50262
F	1	Seal, Trim; 3/4" Bulb, 15/64" Edge (21")	05-01507
G	1	Coupling, Silicone Reducer	05-01358
H	1	Grommet	03-50167
I	1	Fitting, Air Temp Sensor	05-01454
J	1	Plug, Housing	05-01361
K	1	Mini Clamp #10	03-50078
L	1	Silicone Hose (10.5")	05-01502

Tools needed: 8mm and 10mm nut driver or socket & flat head screw driver.

Warranty Information available at: <https://afepower.com/contact#warranty>

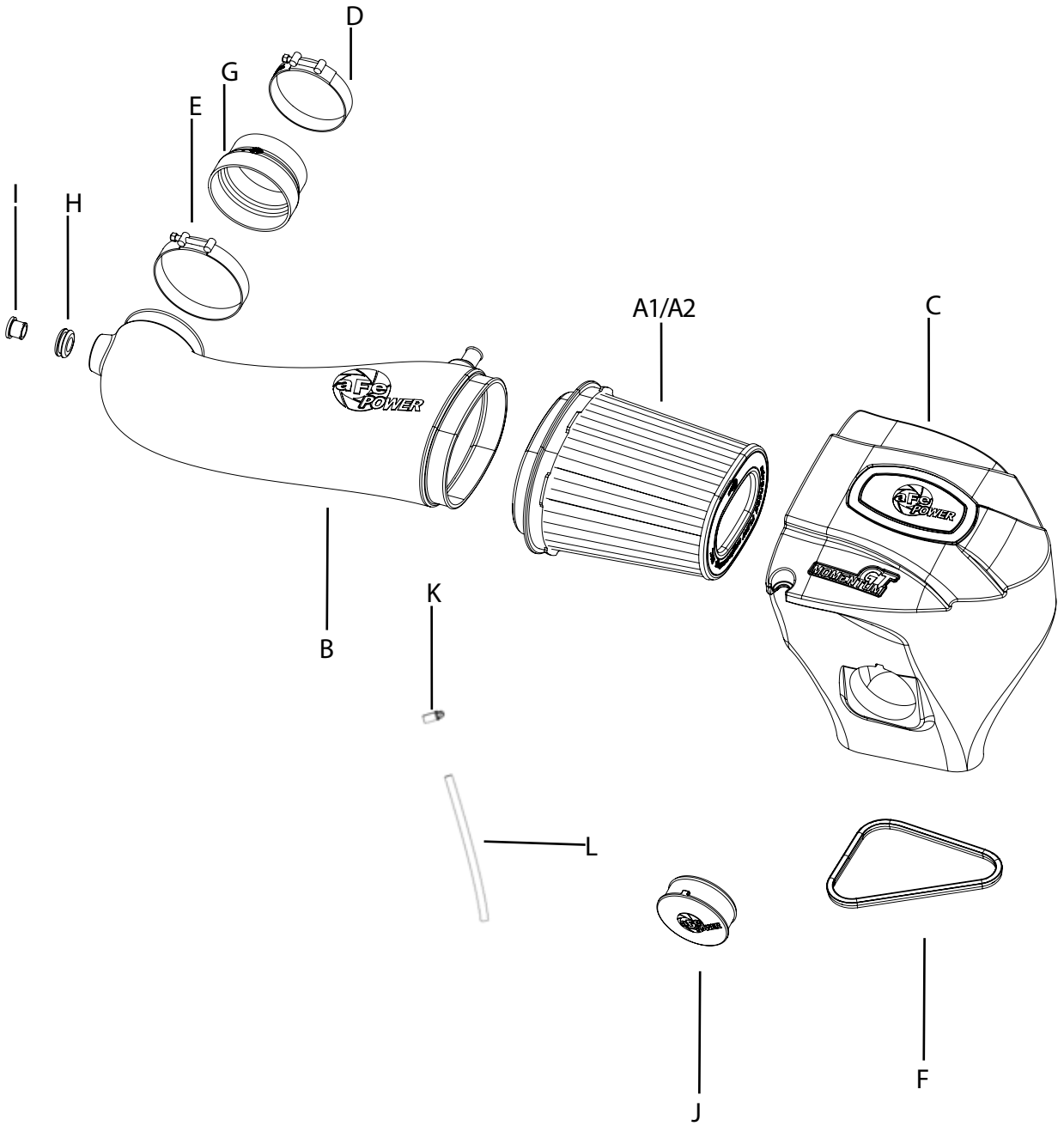



Figure A

Refer to Figure A for Steps 1-5

Step 1: Remove the engine cover. For 2011 to 2019 models disconnect the crank case hose from the intake tube, for 2020+ models remove the crank case hose from the vehicle completely.

Step 2: Remove 8mm bolt off the factory air box.

Step 3: Loosen clamp off the factory intake tube.

Step 4: Unplug Temp sensor.

Step 5: Pull the factory intake air system out of the vehicle.



Figure B

Refer to Figure B for Steps 6-8

Step 6: Transfer the grommet from the factory air box to the aFe housing.

Step 7: Install the trim seal on the bottom edge of the aFe housing.

Step 8: Slide the aFe filter inside the aFe housing until it locks in place. Install clamp on the filter end but do not tighten at this time.



Figure C

Refer to Figure C for Step 9

Step 9: For the 2015+ Challenger, if you wish to use the headlight inlet duct, pop the cap off the center of the headlight and install on the aFe housing the aFe inlet duct (Sold Separately, P/N: 54-72203-S). For all other vehicle, leave the housing inlet open to get more air or close it off with the furnished plug to block off the hot engine air.



Figure D

Refer to Figure D for Steps 10-12

Step 10: Make sure factory grommet is installed correctly into hole.

Step 11: Install aFe housing assembly into vehicle.

Step 12: Install coupling with clamps over the throttle body. Do not tighten yet.



Figure E

Refer to Figure E for Steps 13-14

Step 13: Install grommet into hole in aFe tube then press the fitting in it.

Step 14: Remove the temperature sensor from the factory tube. Secure it into the fitting by turning clockwise.



Figure F

Refer to Figure F for Steps 15-17

Step 15: Install the tube into the vehicle by sliding it first into the filter then into the coupling.

Step 16: For 2011-2019 models connect the factory crank case hose to the aFe POWER tube, for 2020+ models connect the provided hose to the aFe Power tube and secure it on the engine side using the provided clamp.

Step 17: Align tube correctly, then tighten all clamps.



Figure G

Refer to [Figure G](#) for [Steps 18-20](#)

Step 18: Re-connect the temperature sensor.

Step 19: Re-install the factory bolt removed at step 2 to secure the housing.

Step 20: Re-install the engine cover.

NOTE: Place enclosed CARB EO sticker on a smooth/clean surface on or near the air intake system.

EO identification label is required to pass the smog check inspection.

Your installation is now complete. Thank you for choosing aFePower!

PAGE LEFT BLANK INTENTIONALLY



advanced FLOW engineering, inc.
252 Granite Street Corona, CA 92879
<https://afepower.com/contact>