

**GT**  
**MOMENTUM™**

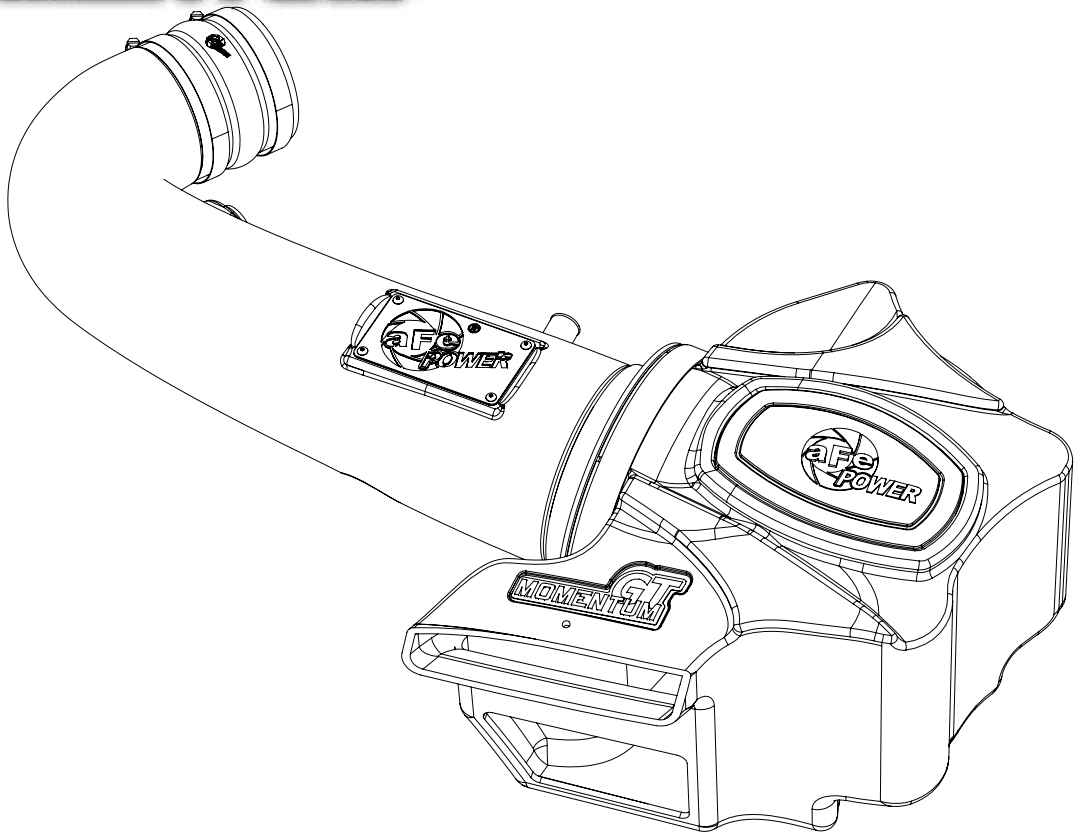

**advanced FLOW engineering**

**Instruction Manual P/N: 51-76205-1 / 54-76205-1**

---

Make: Jeep Model: Grand Cherokee (WK2) Year: 2011-2021 Engine: V8-5.7L HEMI  
Make: Dodge Model: Durango Year: 2011-2021 Engine: V8-5.7L HEMI



- Please read the entire instruction manual before proceeding.
- Ensure all components listed are present.
- If you are missing any of the components, call customer support at 951-493-7185.
- Ensure you have all necessary tools before proceeding.
- Do not attempt to work on your vehicle when the engine is hot.
- Disconnect the negative battery terminal before proceeding.
- Retain factory parts for future use.

| Label | Qty. | Description                               | Part Number |
|-------|------|---|-------------|
| A1    | 1    | Air Filter Pro-5R (Blue Media)            | 24-91062    |
| A2    | 1    | Air Filter Pro DRY S (Grey Media)         | 21-91062    |
| B     | 1    | Housing                                   | 05-76214B2  |
| C     | 1    | Tube                                      | 05-76205B1  |
| D     | 1    | Clamp, T-Bolt                             | 03-50290    |
| E     | 1    | Coupling, Silicone Bellow: 3-1/2"ID x 3"L | 05-01389    |
| F     | 2    | Clamp 056 (3-1/16" - 4")                  | 03-50009    |
| G     | 1    | Grommet, Rubber                           | 03-50167    |
| H     | 1    | Fitting, Air Temp Sensor                  | 05-01454    |

Tools Needed: 8mm nut driver, 10mm nut driver, 10mm deep socket, 11mm deep socket, 1/4" ratchet, panel popper (recommended)

Warranty Information available at: <https://afepower.com/contact#warranty>

Note: Legal in California for use on race vehicles only. The use of this device on vehicles used on public streets or highways is strictly prohibited in California and others states that have adopted California emission regulations.

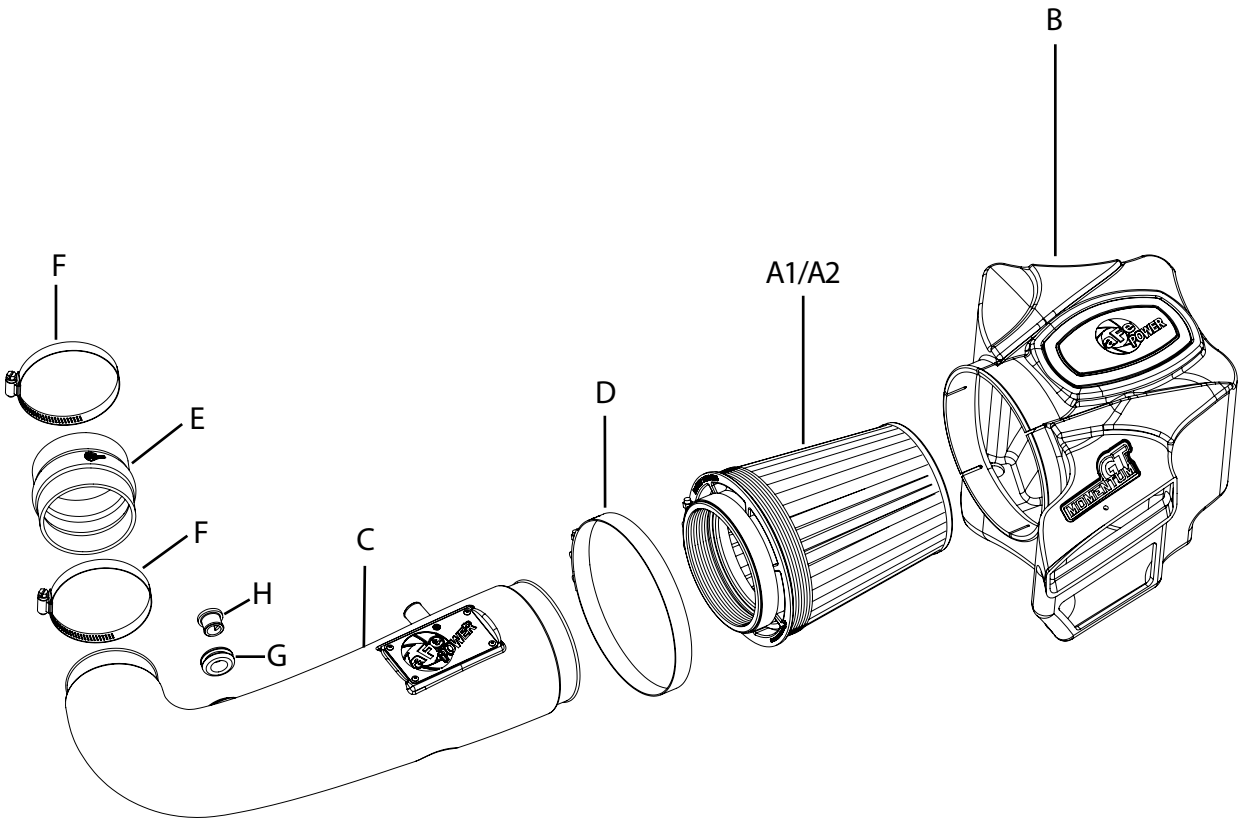



FigureA

Refer to Figure A for Step 1

Step 1: Remove engine cover by pulling straight up.



Figure B

Refer to Figure B for Steps 2-6

Step 2: Using 8mm nut driver, remove support screw (1)

Step 3: Disconnect temperature sensor harness (2).

Step 4: Disconnect crank case vent hose (3).

Step 5: Using 8mm nut driver, loosen band clamp on throttle body (4)

Step 6: If equipped, unclip vent hose on the backside of the factory housing (5)

**FigureC**

Refer to Figure C for Steps 7-8

Step 7: Carefully pull up and remove trim seal on top of the factory intake scoop and 2-3 clips on either side. This helps with the removal of the factory airbox and installation of the aFe housing (6).

Note: It may help to use a panel popper when pulling the clips.

Step 8: At this time, pull the intake tube off the throttle body and pull up to remove the entire factory intake.



FigureD

Refer to Figure D for Step 9

Step 9: Transfer factory rubber grommets to aFe housing as shown ⑦.

**FigureE**

Refer to Figure E for Steps 10-13

Step 10: To remove the temperature sensor from the factory tube, twist counter-clockwise and carefully pull. Do not damage sensor.

Step 11: Insert the supplied grommet into the aFe intake tube (8)

Step 12: Insert the supplied Temp. sensor fitting into the grommet (8)

Note: It may help to use a small amount of lubricant on the inside of the rubber grommet.

Step 13: Insert the OE Temp. sensor into the aFe fitting, twist clockwise until sensor locks into fitting.



Figure F

Refer to Figure F for Steps 14-16

Step 14: Pre assemble the housing as shown by inserting the aFe filter into the housing and tightening the large t-bolt clamp using your nut driver (9).

Step 15: Install the housing assembly into the vehicle. It may help to align the back rubber grommet with your hand first and the others will follow.

Step 16: Slip the smaller t-bolt clamp over the filter flange, but do not tighten at this time.

**Figure G**

Refer to Figure G for Steps 17-18

Step 17: Slip one band clamp over the provided silicone hump coupler and slide over the throttle body.

Tighten clamp using 8mm nut driver. Slip remaining band clamp over the other end of the coupling but do not tighten at this time ⑩

Step 18: Insert tube into filter as shown. Rotate tube down and insert other end into hump coupler. Align the tube to the filter and coupling, then tighten all clamps at this time.



Figure H

Refer to Figure H for Steps 19-23

Step 19: Reconnect temperature sensor harness (11).

Step 20: Reinstall engine cover (12).

Step 21: Reconnect crank case vent hose to aFe tube at this time (13).

Step 22: Reinstall the rubber trim seal into factory locations and onto the aFe housing (14).

Step 23: Verify all connections are secured. Your installation is now complete.

NOTE: Check all clamps and connectors after 200 miles.

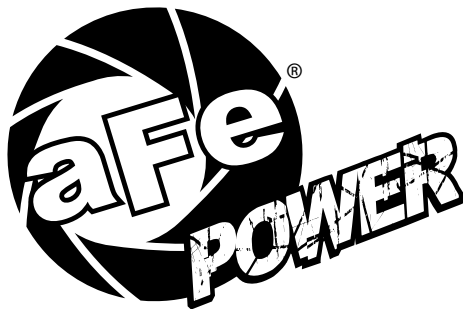

**advanced FLOW engineering, inc.**

252 Granite Street Corona, CA 92879

<https://afepower.com/contact>