

advanced FLOW engineering

Instruction Manual P/N: 51-76306 / 54-76306

Make: **BMW** Model: **335i/is/xi (E90/92/93)** Year: **2007-2010** Engine: **L6-3.0L (tt) N54**



- Please read the entire instruction manual before proceeding.
- Ensure all components listed are present.
- If you are missing any of the components, call customer support at 951-493-7100.
- Ensure you have all necessary tools before proceeding.
- Do not attempt to work on your vehicle when the engine is hot.
- Disconnect the negative battery terminal before proceeding.

Retain factory parts for future use.

Label	Qty.	Description	Part Number
A1	1	Pro DRY S Air Filter	21-90089 (Gray Media)
A2	1	Pro 5R Air Filter	24-90089 (Blue Media)
B	1	Housing	05-76306B2
C	1	Tube	05-76306B1
D	1	Plug, Urethane	05-01225

Installation will require the following tools:
T20 Torx, 6mm nut driver, 10mm nut driver, 1/4" Driver, & 6mm Deep Socket.

Warranty Information available at <https://afepower.com/contact#warranty>

Note: Legal in California for use on race vehicles only. The use of this device on vehicles used on public streets or highways is strictly prohibited in California and others states that have adopted California emission regulations.

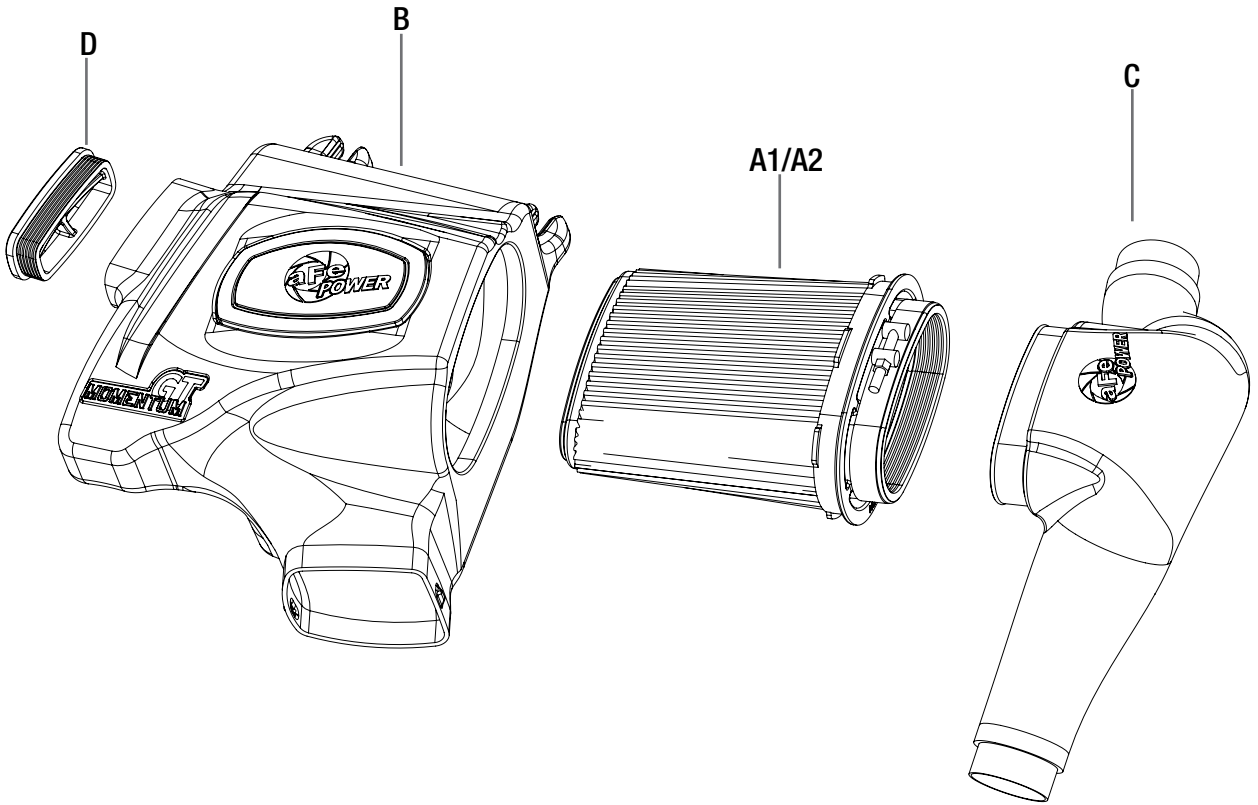

**Figure A****Refer to Figure A for Steps 1-3**

Step 1: Disconnect the crank case vent (CCV) ① by squeezing the sides and lifting straight up, and tie it up out of the way. Careful not to bend this line too much so that it does not kink.

Step 2: Remove the two T20 Torx screws ② in the front of the air inlet scoop.

Step 3: Remove the factory air inlet scoop ③, and set it aside for reuse later.



Figure B

Refer to Figure B for Steps 4-5

Step 4: Loosen the two clamps on the air intake. One is visible at this point and the other is located behind the air intake box under the cowl. You will need a 1/4" driver with a 6mm deep socket to reach the clamp in the back of the housing.

Step 5: Disconnect the three wire harnesses on the back of the air intake tube.



Refer to Figure C for Steps 6-7

Step 6: Remove the air box by lifting up on the three mounting points. These rubber grommets can be tight, so a decent amount of pressure is required.

Step 7: Remove the air box from the vehicle.



Refer to Figure D for Step 8

Step 8: Remove one of the grommets from the bottom of the factory air box and set it aside for later use.

**Figure E****Refer to Figure E for Steps 9-10**

Step 9: Install the aFe air filter into the new Momentum intake housing. There are small tabs that will create a positive lock when the filter is fully engaged.

Step 10: Place the included stainless steel T-bolt clamp over the filter as shown and leave the clamp loose.



Figure F

Refer to Figure F for Step 11

Step 11: Install the factory grommet into the large hole from the bottom of the Momentum intake housing.



Figure G

Refer to Figure G for Steps 12-13

Step 12: To install the Momentum intake housing, slide the two clips on the housing over the two rear mounting post on the intake manifold.

Step 13: Snap the front of the air box down over the front mounting post to fully secure the air box.



Figure H

Refer to Figure H for Steps 14-15

Step 14: Install the new Momentum intake tube into the vehicle by inserting the two ends into the factory inlets first and then rotating the tube into the aFe air filter.

Step 15: Tighten all three clamps at this time, but be careful not to over tighten the clamps.



Figure I

Refer to Figure I for Step 16

Step 16: Reinstall the factory intake scoop and secure it with the two T20 Torx screws.



Figure J

Refer to Figure J for Steps 17-18

Step 17: Reconnect the CCV fitting.

Step 18: Install optional plug at this time if you would like to use it.



Figure K

Refer to Figure K for Step 19

Step 19: Your installation is now complete!

NOTE: Retighten all connections after approximately 100-200 miles.

This Page left blank intentionally.

advanced FLOW engineering, inc.