

advanced FLOW engineering

Instruction Manual P/N: 51-76402 / 54-76402

Make: **Audi** Model: **A4 (B8)** Year: **2009-2016** Engine: **I4-2.0L (t)**



- Please read the entire instruction manual before proceeding.
- Ensure all components listed are present.
- If you are missing any of the components, call customer support at 951-493-7100.
- Ensure you have all necessary tools before proceeding.
- Do not attempt to work on your vehicle when the engine is hot.
- Disconnect the negative battery terminal before proceeding.
- Retain factory parts for future use.

Retain factory parts for future use.

Label	Qty.	Description	Part Number
A1	1	Air Filter (Pro 5R)	24-91113
A2	1	Air Filter (Pro DRY S)	21-91113
B	1	Tube	05-76402B1
C	1	Housing w/ Integrated Heatshield	05-76402B2
D	1	Coupling, Silicone Elbow	05-01421
E	2	Clamp, #044	03-50019
F	1	MAF Sensor Extension Harness	05-70018
G	1	T20 Torx Security Bit	03-50066

Installation will require the following tools:

7mm, 8mm nut drivers, 7mm socket and 1/4" socket driver, flat head screwdriver, T30 Torx Bit and 1/4" Bit Driver.

Note: Legal in California for use on race vehicles only. The use of this device on vehicles used on public streets or highways is strictly prohibited in California and others states that have adopted California emission regulations.

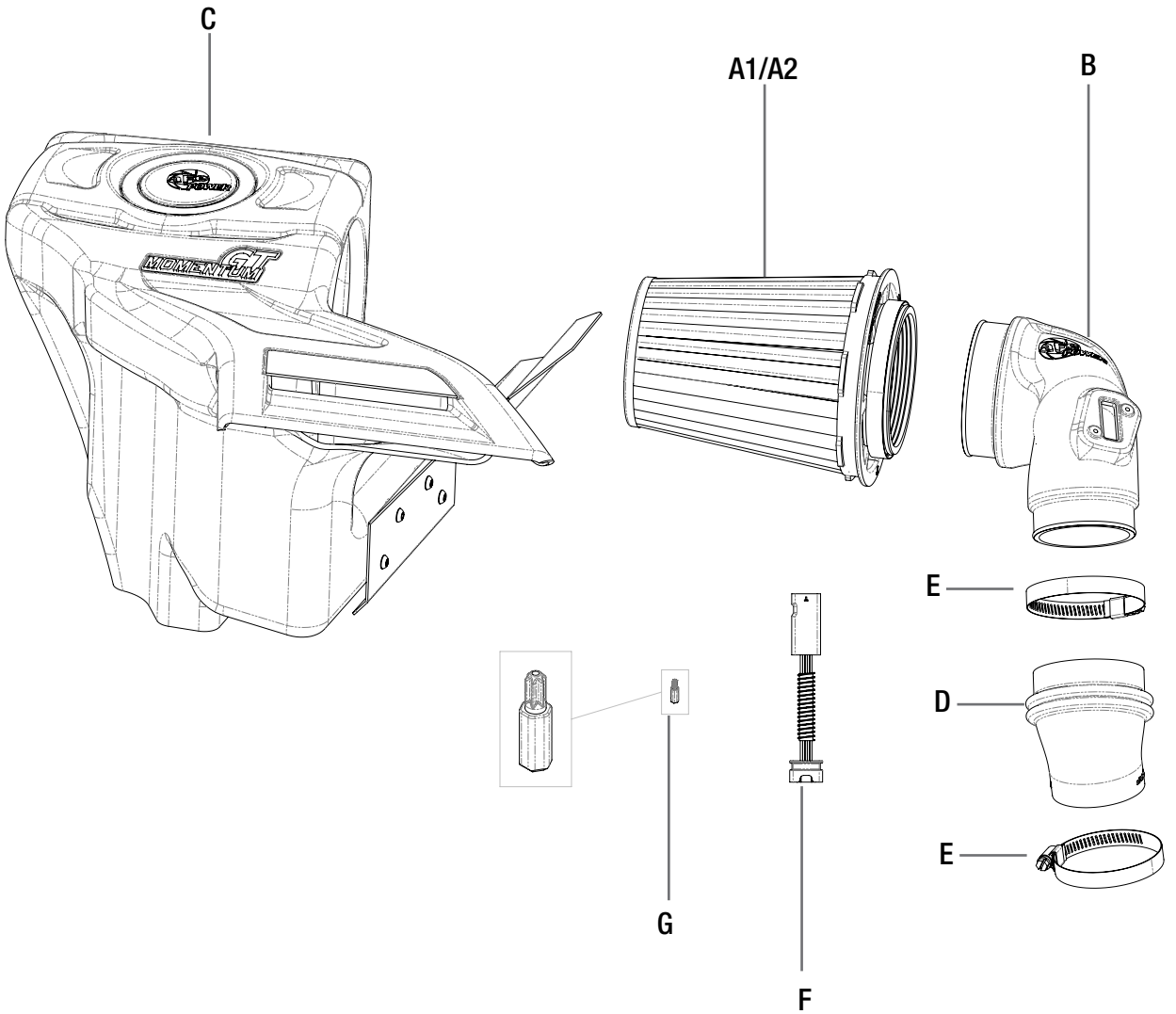

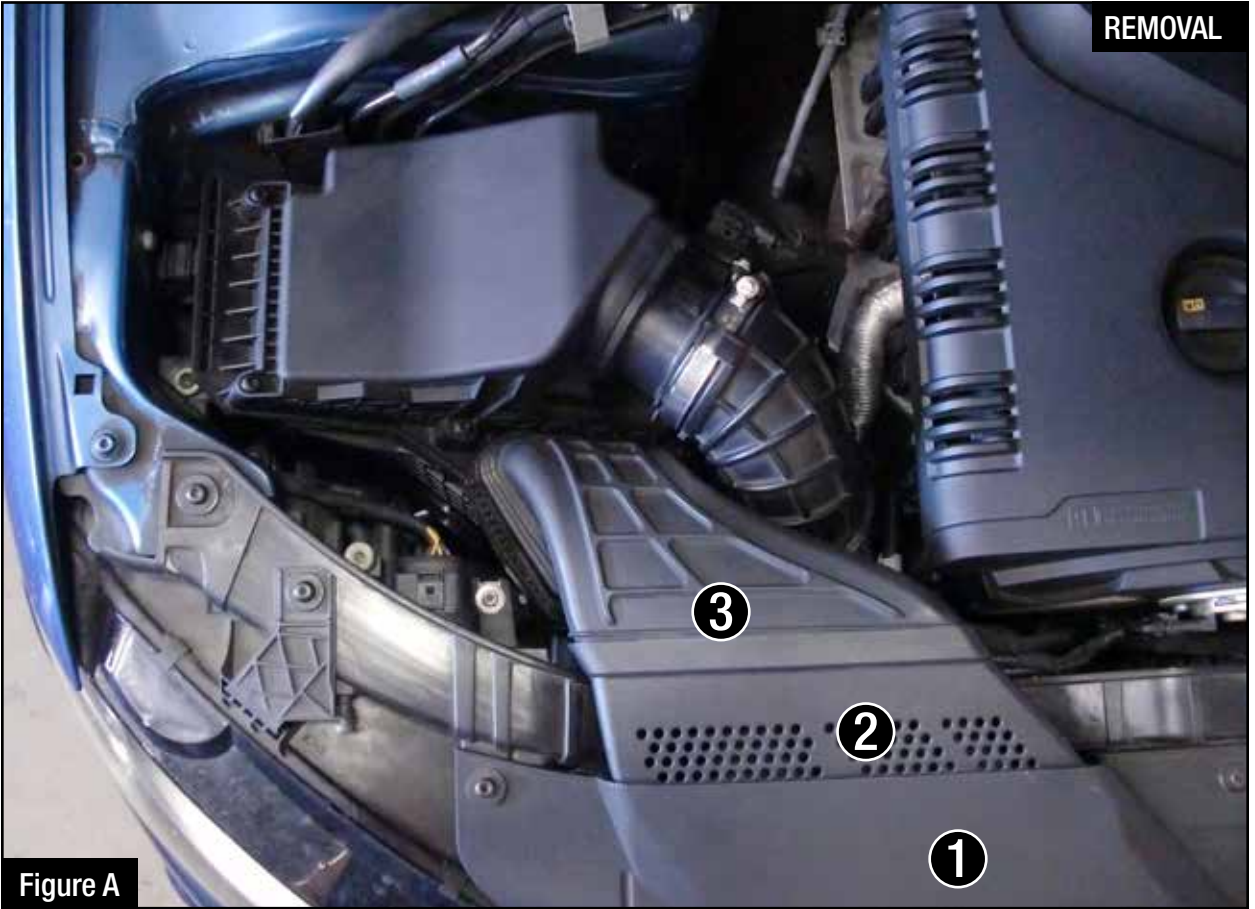
**Figure A****Refer to Figure A for Steps 1-2**

Step 1: Remove the (4) screws that secure the plastic cover (1) that is covering the factory vented shroud (2) and then remove the cover.

Step 2: Remove the factory intake scoop (3) and vented shroud. Use a small flat blade screwdriver to unclip the clips on either side of the vented shroud.

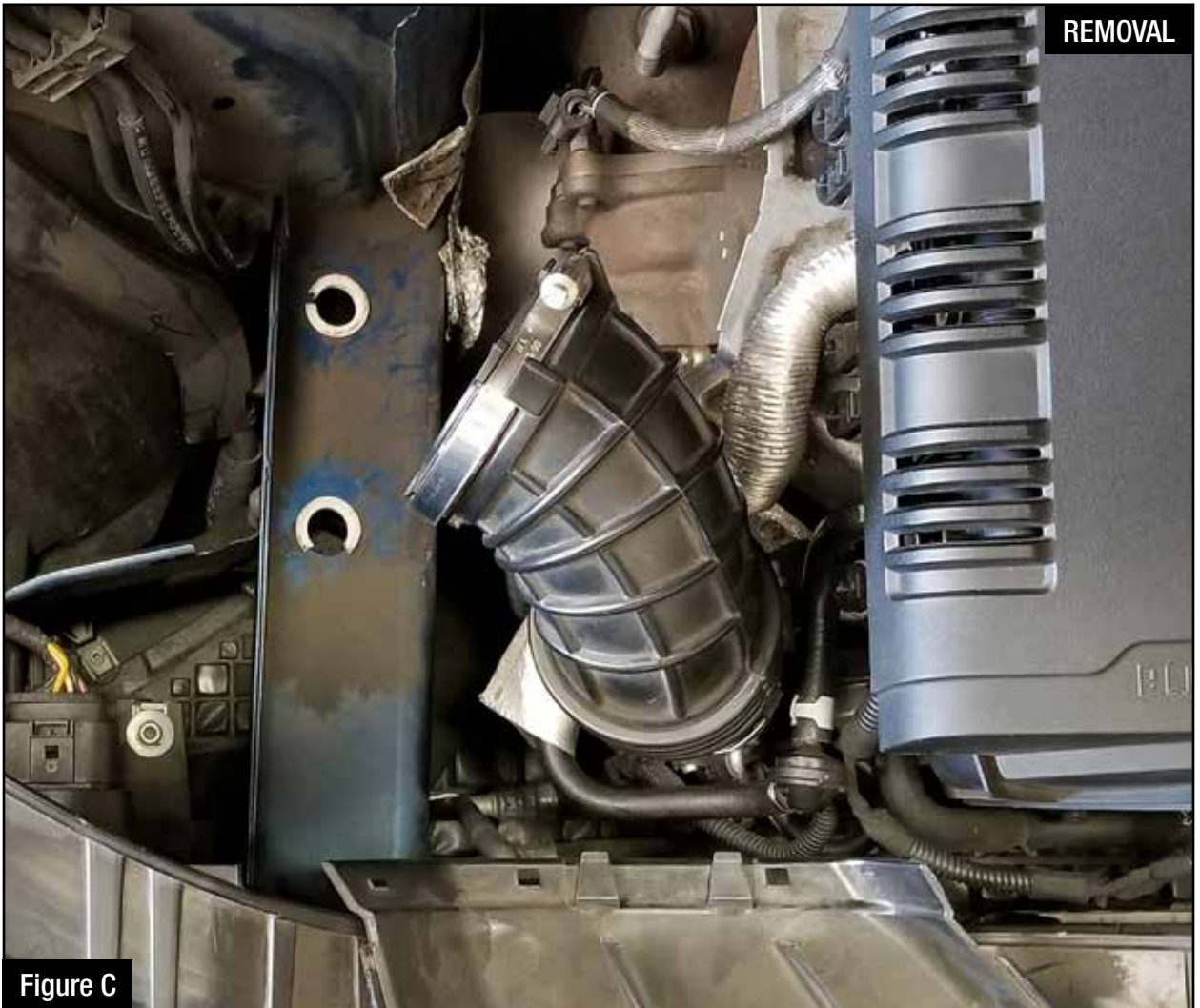

Figure B

Refer to Figure B for Steps 3-4

Step 3: Disconnect the MAF sensor harness from the intake. ④

Step 4: Loosen the hose clamp on the factory intake coupler using a 7mm nut driver.



REMOVAL

Figure C

Refer to Figure C for Steps 5-6

Step 5: Remove the hose clamp on the bottom of the factory intake coupler using a 7mm socket and driver.

Step 6: Remove the factory intake coupler.

**Figure D****Refer to Figure D for Steps 7-8**

Step 7: Install the new aFe coupler and clamps as shown with the angle pointing straight back towards the turbo. You can use the small parting line on the coupler to make sure that this is lined up properly.

Step 8: Tighten the bottom clamp around the turbo inlet, but leave the top clamp loose.

**Figure E****Refer to Figure E for Steps 9-10**

Step 9: Remove the two rubber mounting grommets from the factory air box and relocate them to the new aFe air box.

Step 10: The heat shield has been preinstalled with Loctite, however, please check to make sure that all 4 screws are installed and torqued properly at this time.



Figure F

Refer to Figure F for Step 11

Step 11: Install the aFe housing into the vehicle by dropping it straight down into the holes in the frame rail. Please note that the housing might be a little loose at this point, however, after the tube is installed everything will fit tightly.



Figure G

Refer to Figure G for Step 12

Step 12: Install the air filter into the air box and press it into place. You should be able to hear and feel the 6 tabs lock into place in the housing. Leave the clamp loosely over the air filter.

**Figure H****Refer to Figure H for Steps 13-14**

Step 13: Use the provided T20 security bit to remove the MAF sensor from the factory intake.

Step 14: Mount the MAF sensor onto the new aFe intake tube using the factory screws and the provided T20 security bit.



Figure 1

Refer to Figure 1 for Step 15

Step 15: Install the intake tube into the coupler first and then into the filter. Make sure that the coupler lines up evenly with the intake tube.



Figure J

Refer to Figure J for Steps 16-18

Step 16: Remove the engine cover

Step 17: Reroute the MAF sensor harness toward the front of the vehicle and behind the other electrical connectors. ⑤ (See new locations above)

Step 18: Connect the new MAF sensor harness extension to MAF sensor harness and then to the MAF sensor.



Figure K

Refer to Figure K for Steps 19-20

- Step 19: Tighten both clamps on the intake tube using a flat blade screwdriver or an 8mm nut driver.
- Step 20: Reinstall the engine cover and make sure that it snaps into place at all four mounting points.



Figure L

Refer to Figure L for Step 21

Step 21: Reinstall the plastic cover over the front of the intake scoop and secure it with the factory screws. Your installation is now complete.

*Verify all connections are secure 100-200 miles after installation



PAGE LEFT BLANK INTENTIONALLY

PAGE LEFT BLANK INTENTIONALLY



Pro DRY S Air Filter



P/N: 21-91113

Pro 5R Air Filter



P/N: 24-91113

Pro DRY S Restore Kit



P/N: 90-59999

Blue Squeeze Restore Kit



P/N: 90-50501

SCORCHER GT Module



P/N: 77-46406

Cat-Back Exhaust System



P/N: 49-46403

To purchase any of the items above, view airflow charts, dyno graphs, photos, and video; please go to aFepower.com.

Warranty

General Terms:

- aFe warrants their products to be free from manufacturer's defects due to workmanship and material.
- This warranty applies only to the original purchaser of the product and is non-transferrable.
- Proof of purchase of the aFe product is required for all warranty claims.
- Warranty is valid provided aFe instructions for installation and/or cleaning were properly followed.
- Proper maintenance with regular inspections of product is required to insure warranty coverage.
- Damage due to improper installation, abuse, unauthorized repair or alteration is not warranted.
- Incidental or consequential damages or cost, including installation and removal of part, incurred due to failure of aFe product is not covered under this warranty.
- All warranty is limited to the repair and/or replacement of the aFe part. To request Return Goods Authorization ("RGA"), email RGA@afepower.com or call (951)493-7100. Upon receipt of the RGA, you must return the product to the address provided in the RGA, freight prepaid and accompanied with a dated proof of purchase and the RGA. Upon receipt of the defective product and upon verification of proof of purchase, aFe will either repair or replace the defective product within a reasonable time, not to exceed thirty days.

Product Category	P/N Prefix	Warranty duration
Direct OE Replacement Filters	10, 11, 30, 31, 71, 73	Life of the vehicle
Racing Filters	18	1 year
Universal	21, 24, 72, TF	2 years
Air Intake Systems	50, 51, 54, 55, 75, TR, TA, TL	2 years
Exhaust Systems	49	2 years
Intercoolers & Intercooler Tubes	46-2	2 years
Intake Manifolds	46-1	2 years
Differential Cover	46-7	Life of the vehicle
Exhaust Manifolds	46	2 years
Throttle Body Spacers	46-3	2 years
Turbochargers	46-6	2 years*
Fluid Filters	44	90 days
Pre-Filters	28	2 years
Heavy Duty OE Replacement	70	2 years
PowerSports OE Replacement	81, 87	2 years
PowerSports Intake Systems	85	2 years

No other warranty expressed or implied applies nor is any person or advanced FLOW engineering authorized to assume any other warranty. Some States do not allow the exclusion or limitation of incidental or consequential damages or do not allow limitations on how long an implied warranty lasts, so the above limitations or exclusions may not apply to you. This warranty gives you specific legal rights, and you may also have other rights which vary from State to State.

*See turbocharger warranty for more info

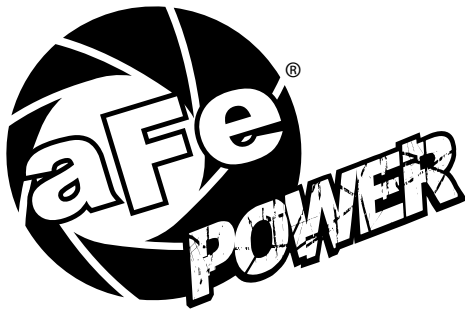

advanced FLOW engineering, inc.
252 Granite Street Corona, CA 92879
TEL: 951.493.7100 * TECH: 951.493.7134
E-Mail: Tech@aFepower.com