

GT
MOMENTUM

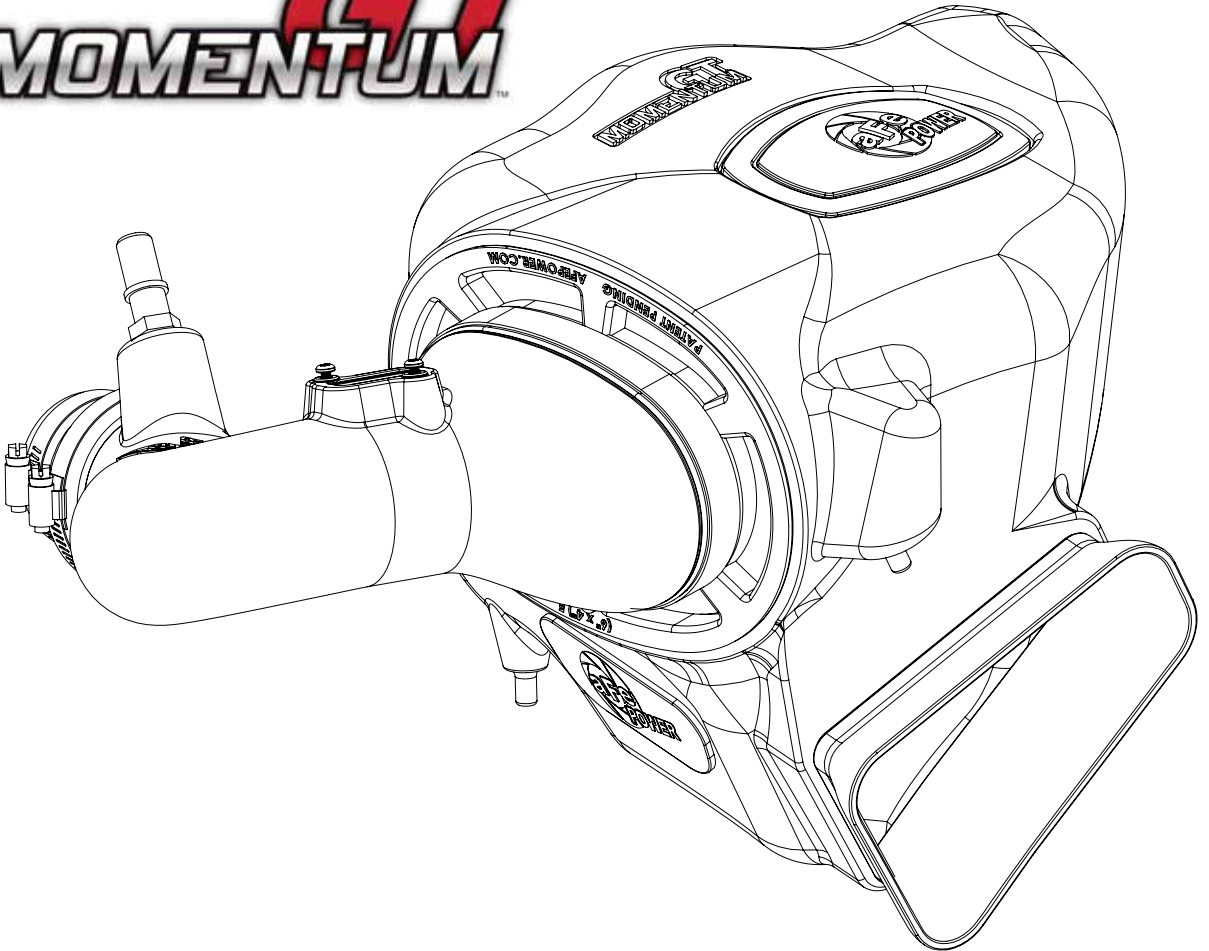

advanced FLOW engineering Momentum GT Cold Air Intake System

Instruction Manual P/N: 51-74212 / 54-74212

Make: **Chevrolet** Model: **Camaro** Year: **2016-2020** Engine: **L4-2.0L Turbo**



- Please read the entire instruction manual before proceeding.
- Ensure all components listed are present.
- If you are missing any of the components, call customer support at 951-493-7100.
- Ensure you have all necessary tools before proceeding.
- Do not attempt to work on your vehicle when the engine is hot.



Retain factory parts for future use.

Label	Qty.	Description	Part Number
A1	1	Air Filter (Pro 5R)	24-91105
A2	1	Air Filter (Pro DRY S)	21-91105
B	1	Tube	05-74212B1
C	1	Housing	05-74210B2
D	1	Clamp, #048	03-50007
E	1	Coupling, Silicone	05-01380
F	1	Fitting, Vent	03-01339
G	1	Clamp, #044	05-50019
H	2	Screw, M4	03-50491
I	1	Plug, Urethane	05-00937
J	1	Scoop	05-74210B3

Installation will require the following tools:

8mm nut driver, 11mm deep socket & driver, T20 Torx, 20mm wrench or adjustable wrench.

Warranty Information available at <https://afepower.com/contact#warranty>

Emissions Disclaimer: This product is not currently CARB exempt and is not available for purchase in California or for use on any vehicle registered with the California Department of Motor Vehicles.

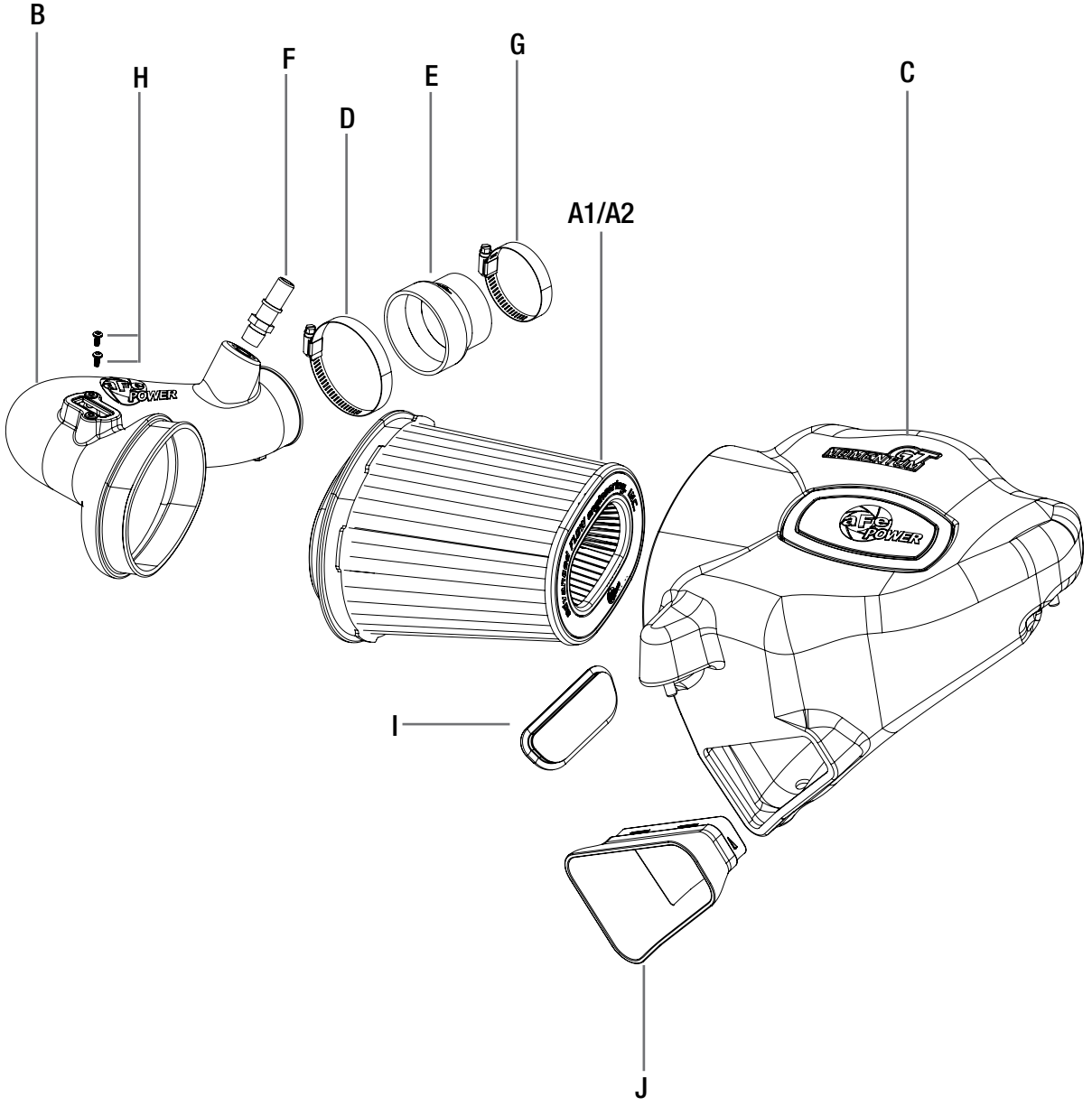

**Figure A****Refer to Figure A for Step 1**

Step 1: Disconnect the braided hose (1) from the intake tube. Disconnect the MAF (2) sensor and pull off the wire harness clip (3) from the intake tube.



Figure B

Refer to Figure B for Step 2

Step 2: Use an 8mm nut driver to loosen the factory clamp (4) at the turbo. Remove the factory intake assembly by pulling up to release air box from its mounting grommets.

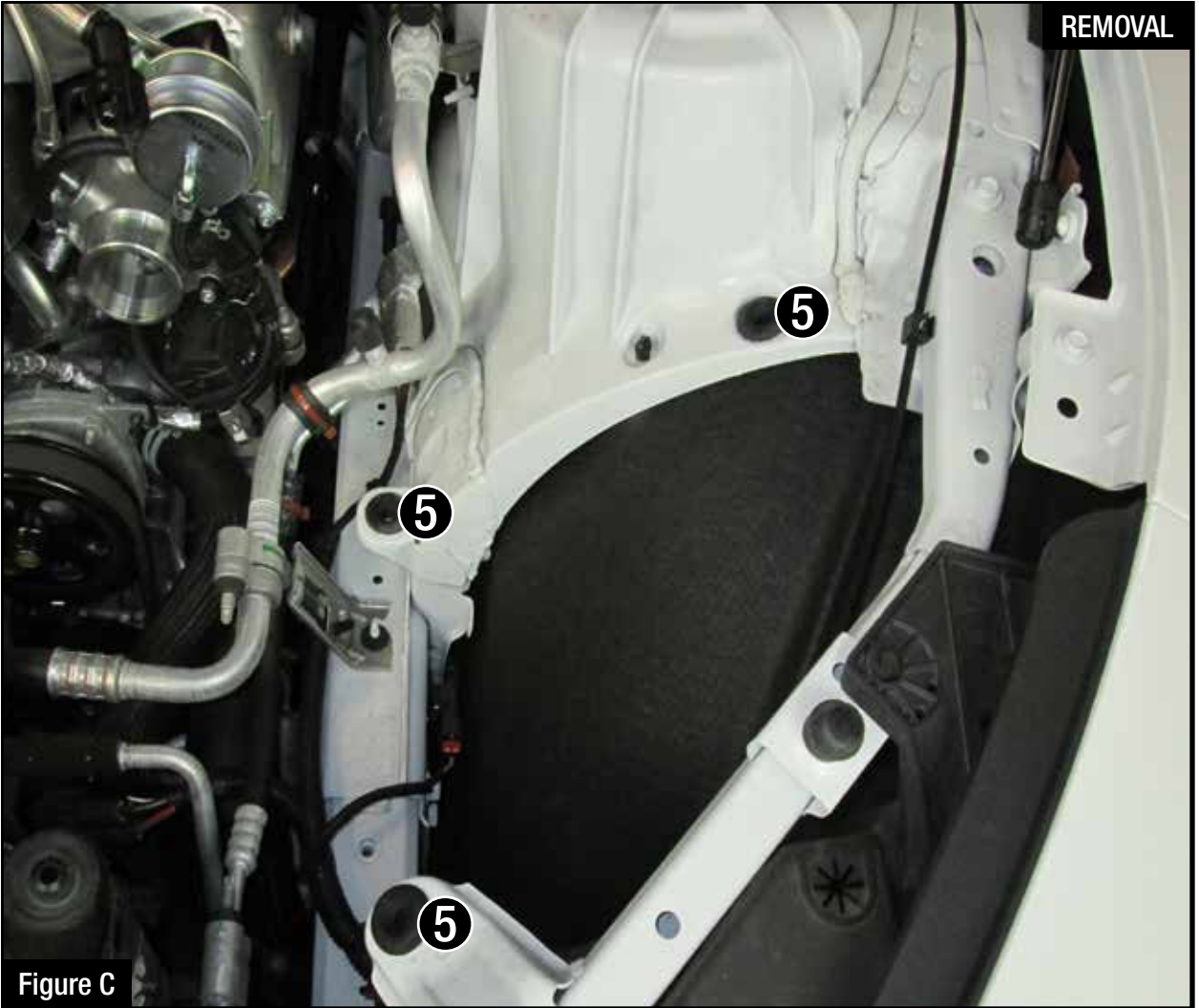

Figure C

Refer to Figure C for Step 3

Step 3: Make sure the mounting grommets (5) are still in the chassis mounting tabs. If they pulled out and are stuck in the lower half of the air box, remove them from the air box and insert them back on the chassis mounting tabs.



Figure D

Refer to Figure D for Steps 4-5

Step 4: Using a Torx 20 driver, remove the mass air flow sensor (6) from the upper half of the air box and install it on the aFe intake tube using the two supplied M4 screws.

Step 5: Install the supplied aluminum vent fitting (7) into the aFe intake tube using a 20mm wrench or adjustable wrench.



Figure E

Refer to Figure E for Steps 6-7

Step 6: Install the supplied air inlet scoop (8) into the aFe air box.

Step 7: Use the provided plug (9) to close additional air inlet if you want to completely seal the air box.

Best performance gain is obtained by having more air flow (no plug).



Figure F

Refer to Figure F for Step 8

Step 8: Slide the aFe filter and clamp into the aFe housing and push it in until it locks into place. Do not tighten clamp at this time.



Figure G

Refer to Figure G for Step 9

Step 9: Install the housing assembly into the vehicle by pushing down air box pins into the rubber grommets. Make sure the pins are completely through the mounting grommets.



Figure H

Refer to Figure H for Step 10

Step 10: Install the supplied silicone coupler (10) with the supplied small clamp onto the turbo and tighten clamp. Install the supplied large clamp on the coupler.



Figure 1

Refer to Figure 1 for Steps 11-12

Step 11: Slide the aFe intake tube into the coupler and then the air filter. Tighten all clamps.

Step 12: Connect the mass air flow sensor (11) and the braided hose (12).

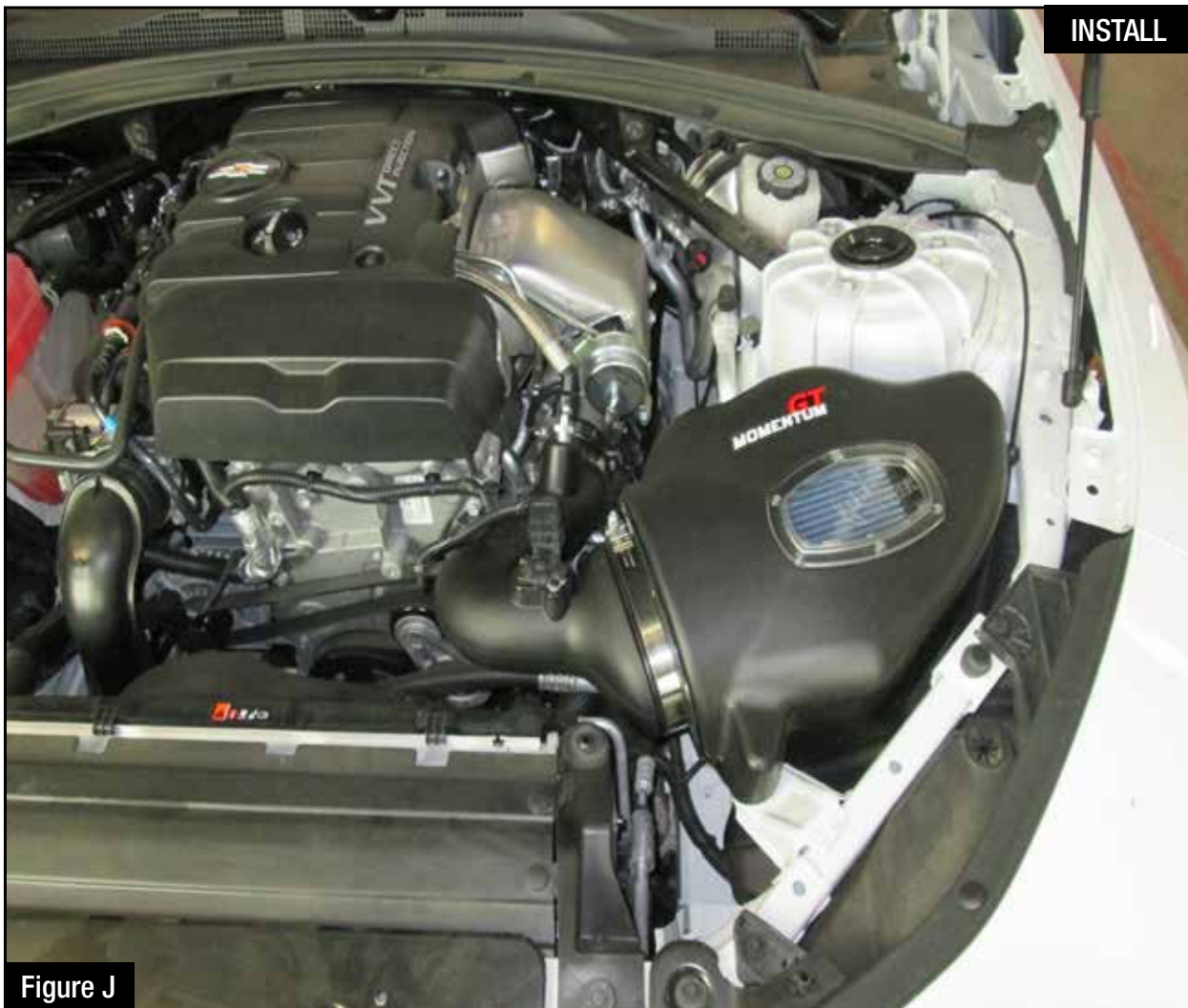

Figure J

Refer to Figure J for Step 13

Step 13: Your installation is now complete. Thank you for choosing aFe Power!

NOTE: Check all bolts, clamps, and connectors after 200 miles.



Page left blank intentionally

Page left blank intentionally

advanced FLOW engineering, inc.