

GT
MOMENTUM™

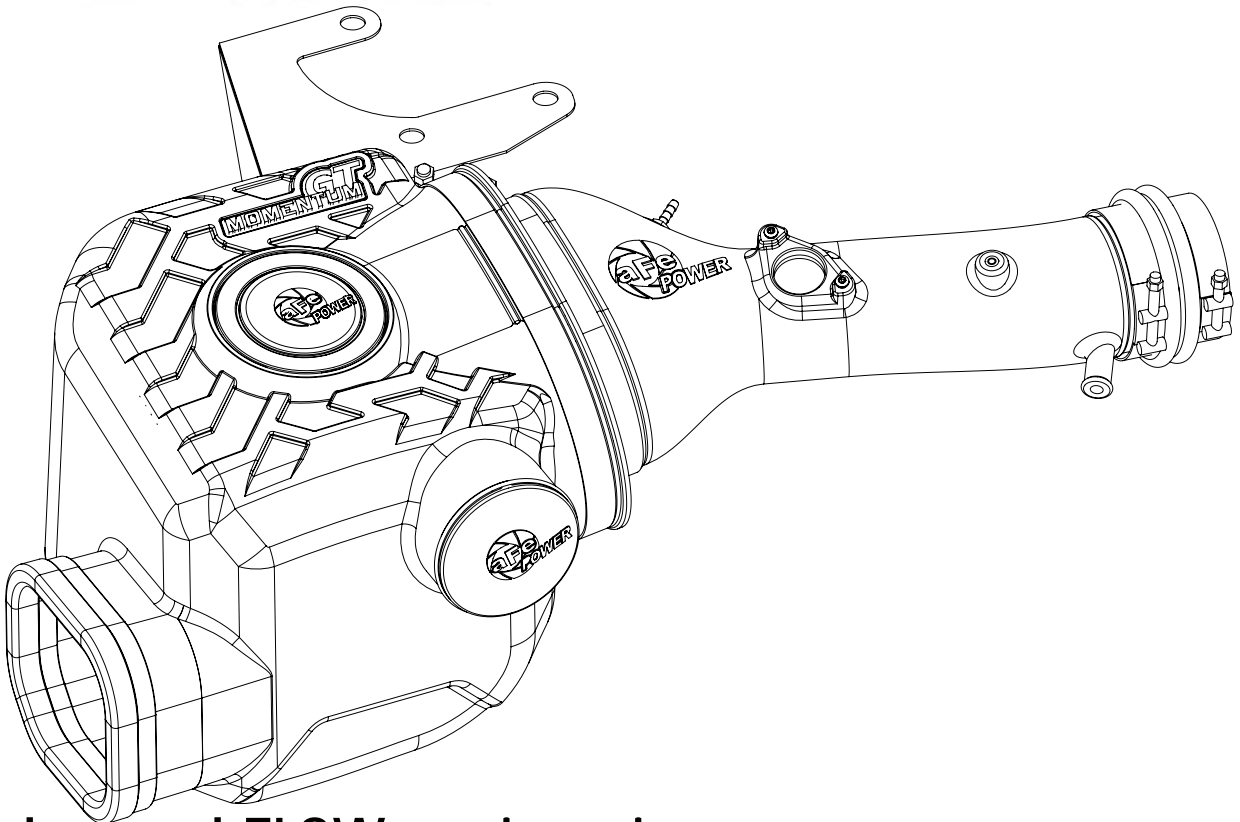

advanced FLOW engineering

Instruction Manual P/N: 51-76012 / 54-76012 / 75-76012

Make: **Toyota** Model: **Tacoma** Year: **2012-2015** Engine: **V6-4.0L**



- Please read the entire instruction manual before proceeding.
- Ensure all components listed are present.
- If you are missing any of the components, call customer support at 951-493-7100.
- Ensure you have all necessary tools before proceeding.
- Do not attempt to work on your vehicle when the engine is hot.

Retain factory parts for future use.

Label	Qty.	Description	Part Number
A1	1	Air Filter (Pro 5R)	24-91123
A2	1	Air Filter (Pro DRY S)	21-91123
A3	1	Air Filter (Pro-GUARD 7)	72-91123
B	1	Tube	05-76004B1
C	1	Housing	05-76004B2
D	1	Plug, Urethane	05-01361
E	1	Seal, Trim (17")	05-00007
F	1	Clamp, T-bolt (3-1/4" - 3-9/16")	05-50292
G	1	Clamp, T-bolt (3-1/16" - 3-3/8")	05-50320
H	1	Clamp, T-bolt (8-5/16" - 8-5/8")	05-50267
I	1	Coupling, Silicone Bellow	05-01470
J	2	Screw, Torx: M4	05-50491
K	1	Brass Hose Nipple	03-50191
L	1	Vacuum Hose: 5/32"ID (16")	05-00122
M	1	Isolation Mount	03-50063
N	1	Washer, Flat: M8 x 24mm OD	03-50065
O	1	Hex Nylon Nut	03-50244
P	1	Bolt, M8 x 1.25 x 25mm	03-50442
Q	1	Relocation Bracket	05-12332B4
R	2	Washer, Fender M6 18mm OD	03-50160
S	2	Screw, Hex Hd: M6 x 1 x16	03-50052

Installation will require the following tools:

10mm nut driver, #1 Phillips screwdriver, 11mm deep socket, 12mm & 13mm sockets and drivers, T20 driver, E6 size star socket, pliers and razor blade.

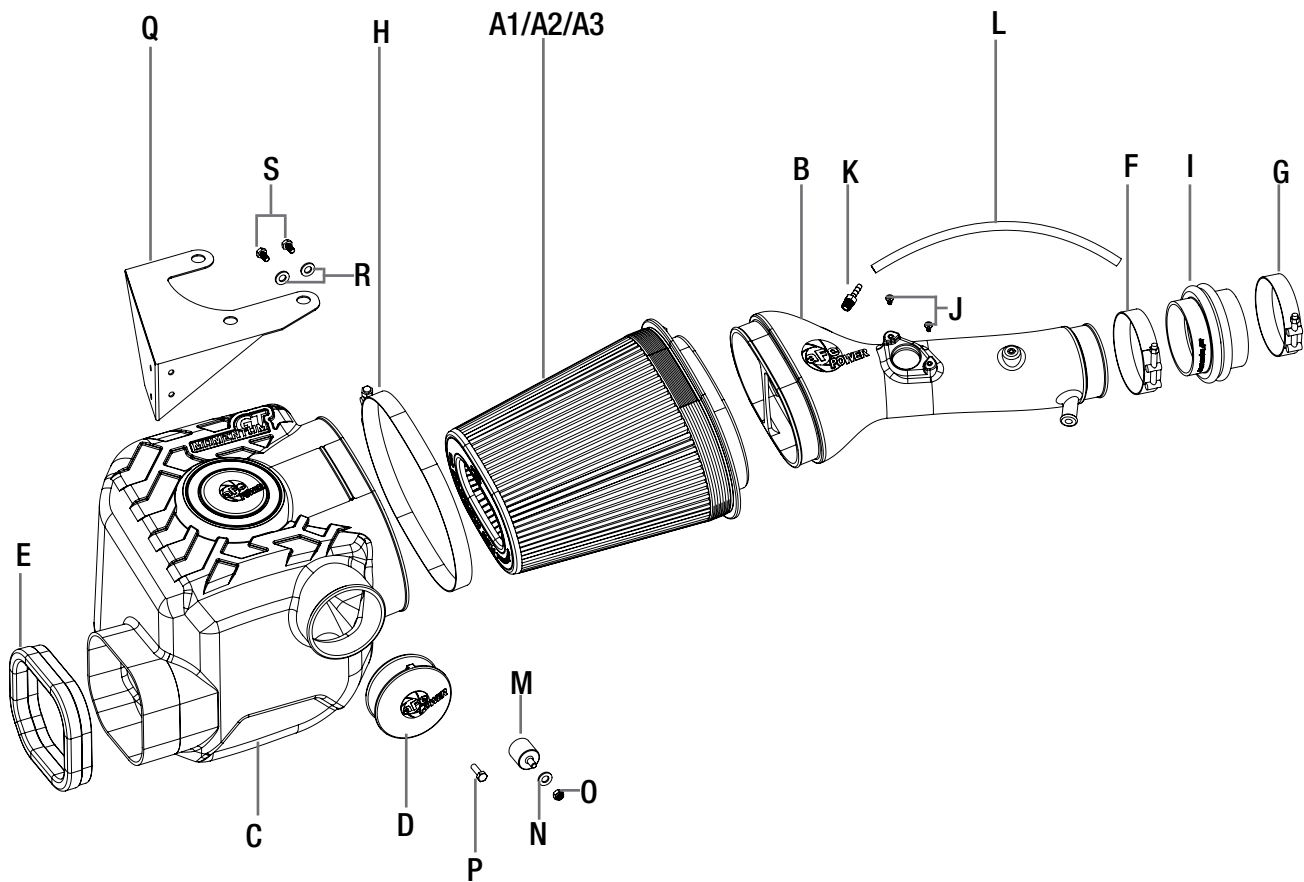

Warranty Information available at <https://afepower.com/contact#warranty>

Emissions Disclaimer: This product is not currently CARB exempt and is not available for purchase in California or for use on any vehicle registered with the California Department of Motor Vehicles.

**Figure A****Refer to Figure A for Step 1**

Step 1: Using a 10mm nut driver, remove the two nuts ① securing the engine cover. Remove the cover by gently pulling it towards the front of the vehicle and lifting up. Set the cover aside.



Figure B

Refer to Figure B for Steps 2-6

Step 2: Using a 10mm nut driver, remove the two screws (2) securing the OE airbox and loosen the clamps (3) at the throttle body and intake snorkel.

Step 3: Disconnect the MAF sensor (4) and wire clips.

Step 4: Disconnect the crank case vent line (5).

Step 5: Disconnect the small vacuum line on the rear of the OE intake (6).

Step 6: Remove the entire stock intake housing by gently pulling it away from the throttle body, then disconnecting from the intake snorkel.

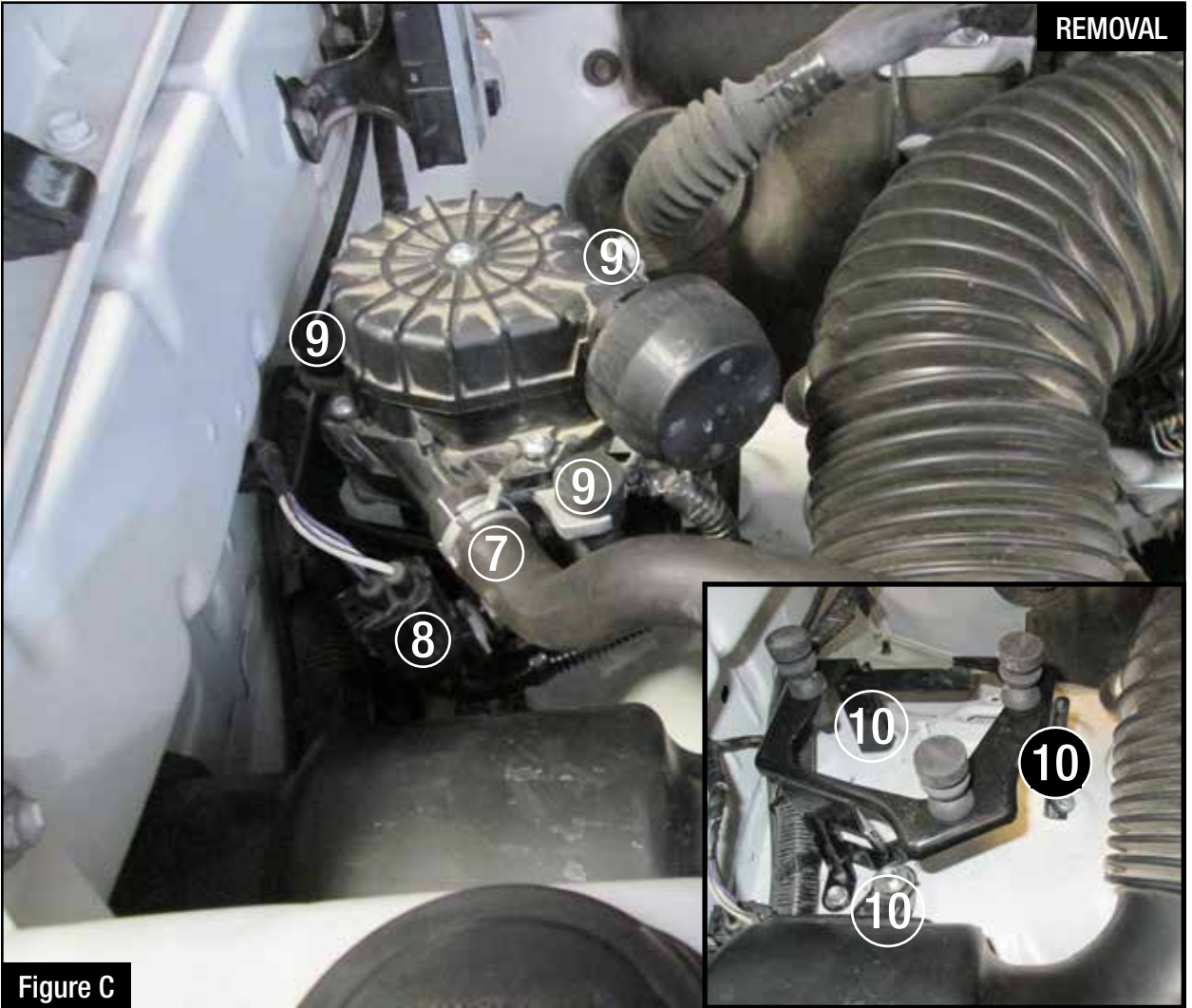

REMOVAL

Figure C

Refer to Figure C for Steps 7-10

Step 7: Using a pair of pliers, disconnect the smog pump airline (7) from the smog pump.

Step 8: Disconnect the smog pump electrical harness. (8)

Step 9: Remove the smog pump from its mounting bracket by disengaging the 3 C-clips from their mounting insulators (9). Set the smog pump aside.

Step 10: Using a 10mm socket and extension, loosen the (3) screws (10) securing the smog pump bracket and remove it from the vehicle.

**Figure D****Refer to Figure D for Step 11**

Step 11: Using a 12mm socket and extension remove the two screws ⑪ holding the OE air intake snorkel and remove.

**Figure E****Refer to Figure E for Step 12**

Step 12: Replace the stock 5/32" vacuum line (12) with the supplied 5/32" vacuum line.



Figure F

Refer to Figure F for Step 13

Step 13: Remove and transfer the (2) steel sleeves and rubber isolation grommets (13) from the stock intake housing to the aFe housing in the rear-most mounting points (14) .

**Figure G****Refer to Figure G for Steps 14-16**

Step 14: Remove the MAF sensor (15) from the OE airbox using a #1 Philips head screwdriver and reinstall into the aFe intake tube using the supplied T20 torx screws.

Step 15: Using an E6 star socket, remove the mounting stud (16) from the OE intake and install into the threaded insert on the aFe intake tube.

Step 16: Install the brass hose fitting (17) into the aFe intake tube, and tighten using an 13mm wrench.

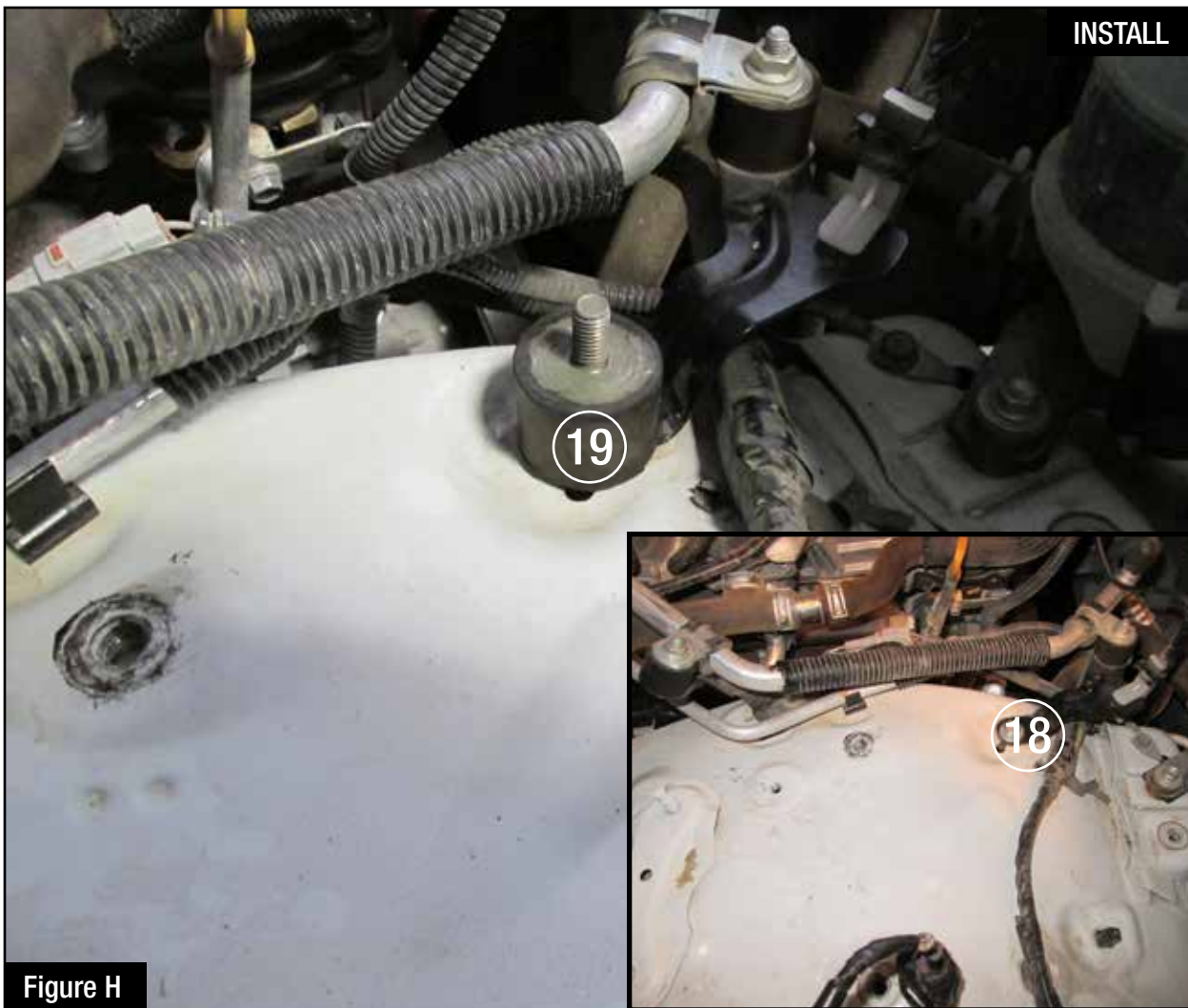

Figure H

Refer to Figure H for Step 17

Step 17: Using a 10mm socket remove the screw (18) holding the A/C bracket and replace it with the supplied M8 isolation mount (19). Hand tighten the rubber isolation mount only.



Figure I

Refer to Figure I for Step 18

Step 18: Install the supplied trim seal on the aFe airbox. Trim to fit.

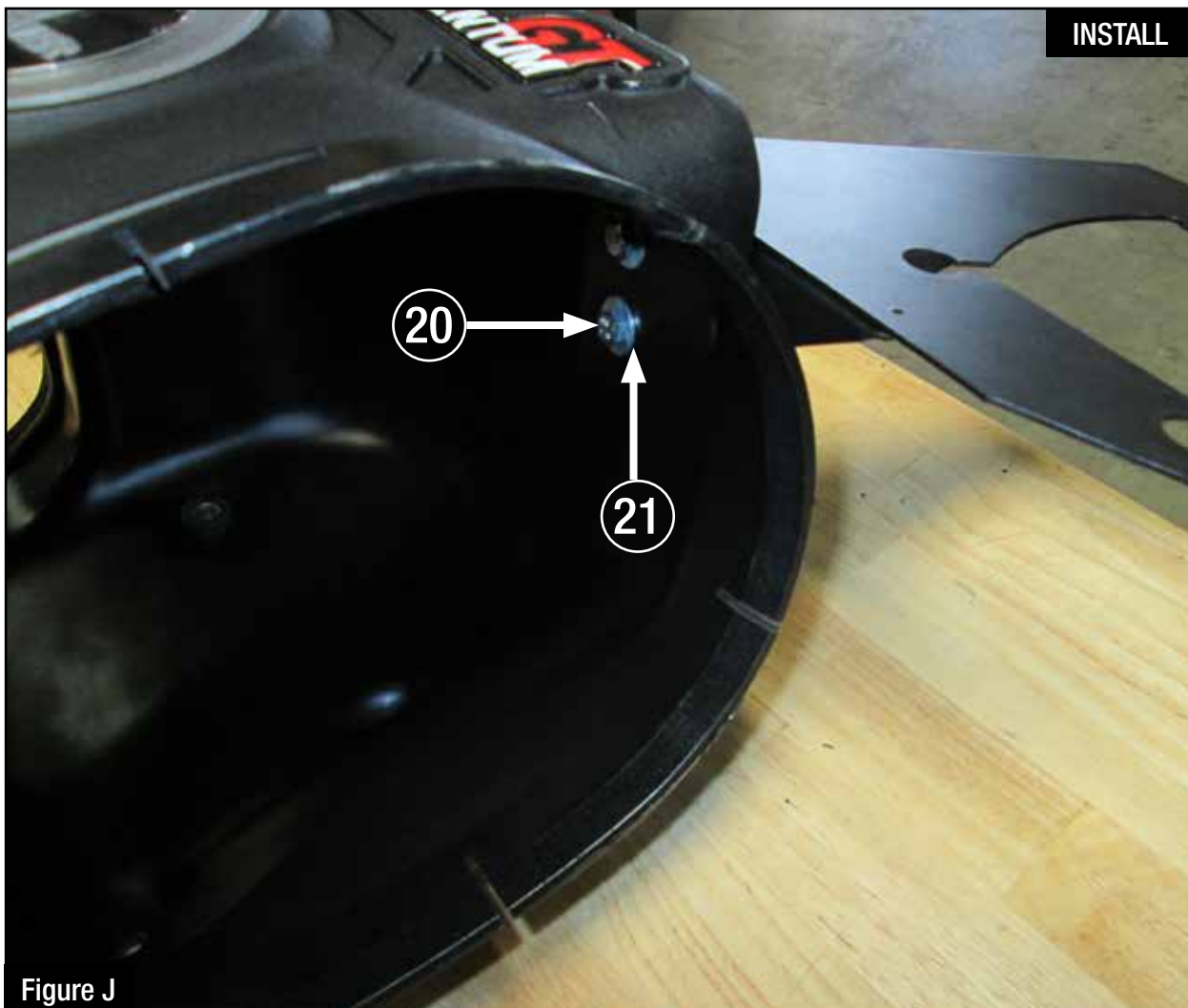

Figure J

Refer to Figure J for Step 19

Step 19: Install the aFe smog pump relocation bracket onto the aFe housing by inserting the screws (20) through the supplied washers (21) the through the drilled holes in the rear of the housing into the pemnuts installed on the relocation bracket. Tighten using a 10mm socket.



Figure K

Refer to Figure K for Step 20

Step 20: Using a razor blade, carefully cut away the electrical tape (22) securing the OE smog pump electrical harness to the larger harness beneath it.

NOTE: Do not over cut.

**Figure L****Refer to Figure L for Step 21**

Step 21: Place the aFe airbox into the vehicle and secure using one of the 12mm screws removed in Step 7 in the left-most mounting location (23). Use the supplied M8 screw in the right-rear mounting location (24) and tighten using a 12mm socket. Using the supplied M8 nut and washer, tighten down the airbox onto the isolation mount (25) using a 13mm socket.



Figure M

Refer to Figure M for Step 22

Step 22: Install the supplied large T-bolt clamp ②6 onto the airbox and slide the air filter into the airbox. Do not tighten the clamp at this time.

**Figure N****Refer to Figure N for Steps 23-24**

Step 23: Install the supplied reducer coupling with the smaller T-bolt clamp (27) onto the throttle body (Lettering on the coupler should be away from the throttle body). Tighten the clamp at the throttle body.

Step 24: Place the larger T-bolt clamp (28) on the coupler, but do NOT tighten at this time.



Figure 0

Refer to Figure 0 for Step 25

Step 25: Install the intake tube into the vehicle by sliding the tube first into the coupler on the throttle body, then into the air filter. Tighten all clamps.



Figure P

Refer to Figure P for Steps 26-27

- Step 26: Transfer the three rubber insulators (29) from the stock smog pump bracket onto the aFe relocation bracket.
- Step 27: Install the smog pump onto the aFe relocation bracket by pressing the rubber insulators into the C-clips attached to the smog pump. It will only line up in a single orientation.



Figure Q

Refer to Figure Q for Steps 28-29

- Step 28: Pass the male side of the electrical harness (30) under the relocation bracket to connect to the female side. (31)
- Step 29: Lay the smog pump airline (32) over the aFe intake tube and reconnect to the smog pump using a pair of pliers.

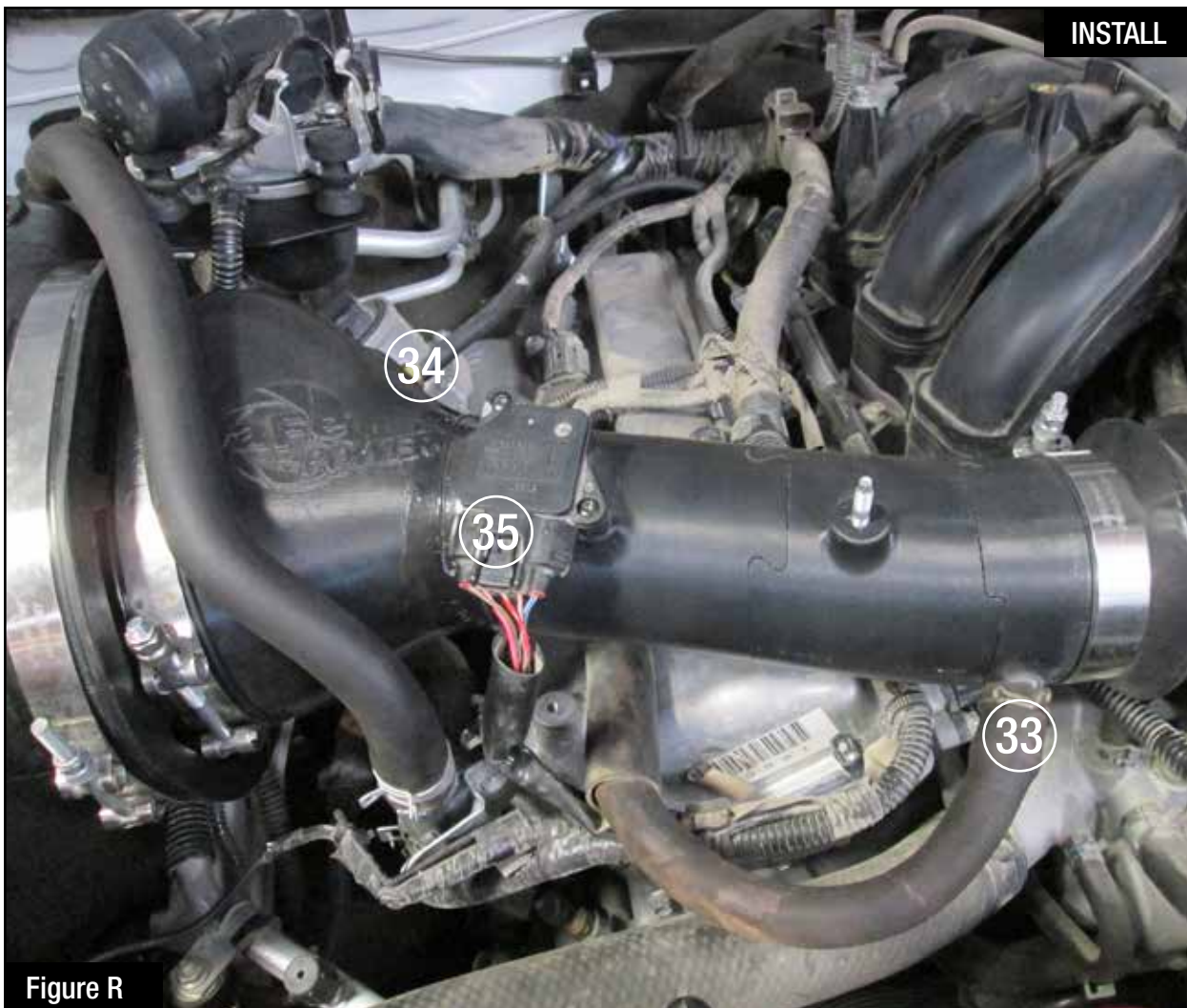

Figure R

Refer to Figure R for Step 30

Step 30: Reconnect the crank case vent hose (33) and 5/32" vacuum line (34) to the aFe intake tube. Reconnect the MAF sensor (35).

**Figure S****Refer to Figure S for Steps 31-32**

Step 31: Reinstall the engine cover utilizing the M6 stud on the aFe intake tube and secure using the stock 10mm nuts.

Step 32: Use the provided plug to close the additional air inlet if you want to completely seal the airbox. Best performance gains are obtained without the plug. Check that all components are tight and secure. Your installation is now complete. Thank you for choosing aFe POWER!

NOTE: Check all bolts, clamps, and connectors after 100-200 miles.

Page left blank intentionally

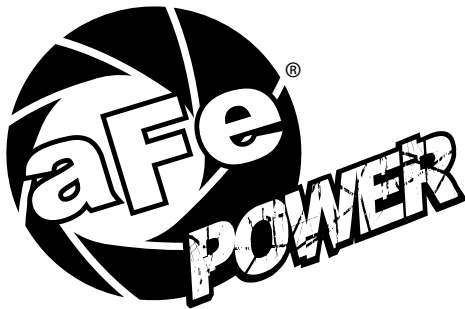

advanced FLOW engineering, inc.

252 Granite Street Corona, CA 92879

<https://afepower.com/contact>