

GT
MOMENTUM™

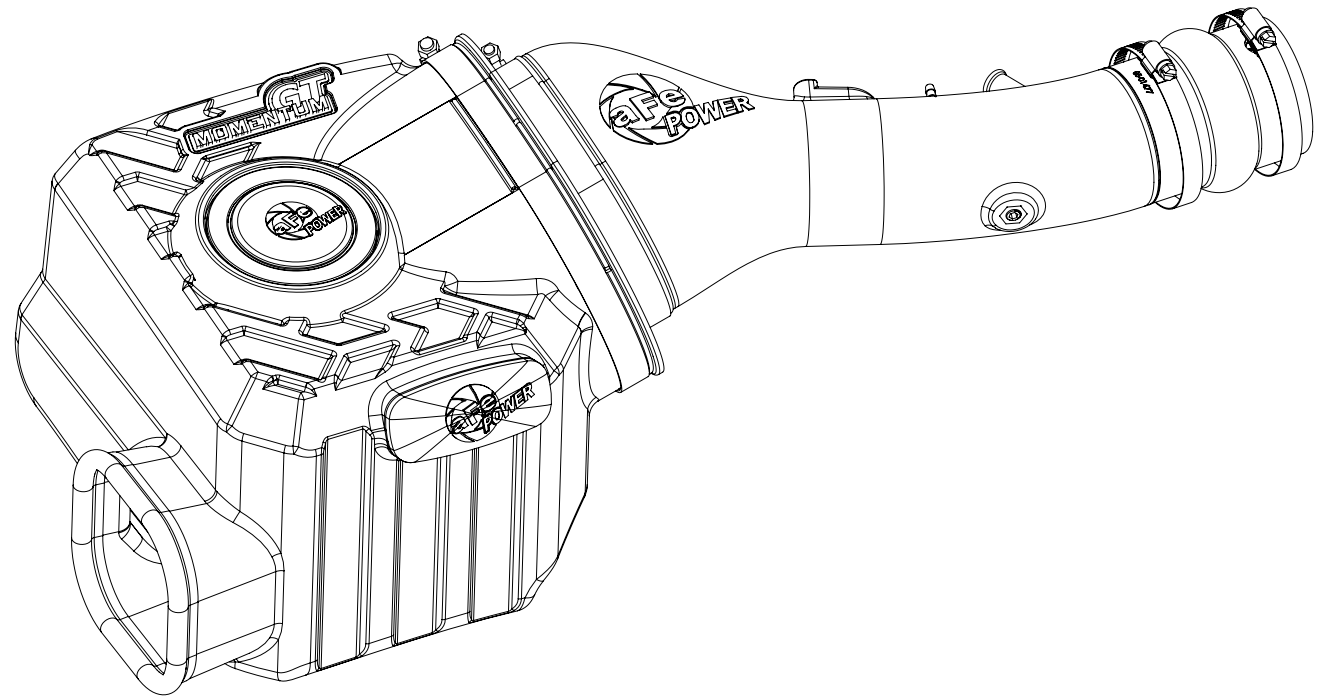

advanced FLOW engineering

Instruction Manual P/N: 51-76013 / 54-76013 / 75-76013

Make: **Toyota** Model: **FJ Cruiser** Year: **2010-2014** Engine: **V6-4.0L w/ Magnuson Supercharger**

Make: **Toyota** Model: **4Runner** Year: **2010-2019** Engine: **V6-4.0L w/ Magnuson Supercharger**



- Please read the entire instruction manual before proceeding.
- Ensure all components listed are present.
- If you are missing any of the components, call customer support at 951-493-7100.
- Ensure you have all necessary tools before proceeding.
- Do not attempt to work on your vehicle when the engine is hot.

Retain factory parts for future use.

Label	Qty.	Description	Part Number
A1	1	Air Filter (Pro 5R)	24-91116
A2	1	Air Filter (Pro DRY S)	21-91116
A3	1	Air Filter (Pro-GUARD 7)	72-91116
B	1	Tube	05-76013B1
C	1	Housing	05-76010B2
D	1	Plug, Urethane	05-01225
E	1	Seal, Trim (17")	05-00007
F	2	Clamp, #052	03-50008
G	1	Clamp, T-bolt (8-5/16" - 8-5/8")	03-50267
H	1	Coupling, Silicone Hump	05-01477
I	2	Screw, Torx: M4	03-50491
J	1	Brass Hose Nipple	03-50191
K	1	Isolation Mount	03-50063
L	1	Washer, Flat: M8 x 24mm OD	03-50065
M	1	Hex Nylon Nut	03-50244
N	1	Bolt, M8 x 1.25 x 25mm	03-50442
O	1	Plug, Hex Hd, Socket: 1/8" NPT	03-50029

Installation will require the following tools:

8mm & 10mm nut driver, #1 Phillips screwdriver, 11mm deep socket, 12mm & 13mm sockets and drivers T20 driver and 3/16" Allen key.

Warranty Information available at <https://afepower.com/contact#warranty>

Emissions Disclaimer: This product is not currently CARB exempt and is not available for purchase in California or for use on any vehicle registered with the California Department of Motor Vehicles.

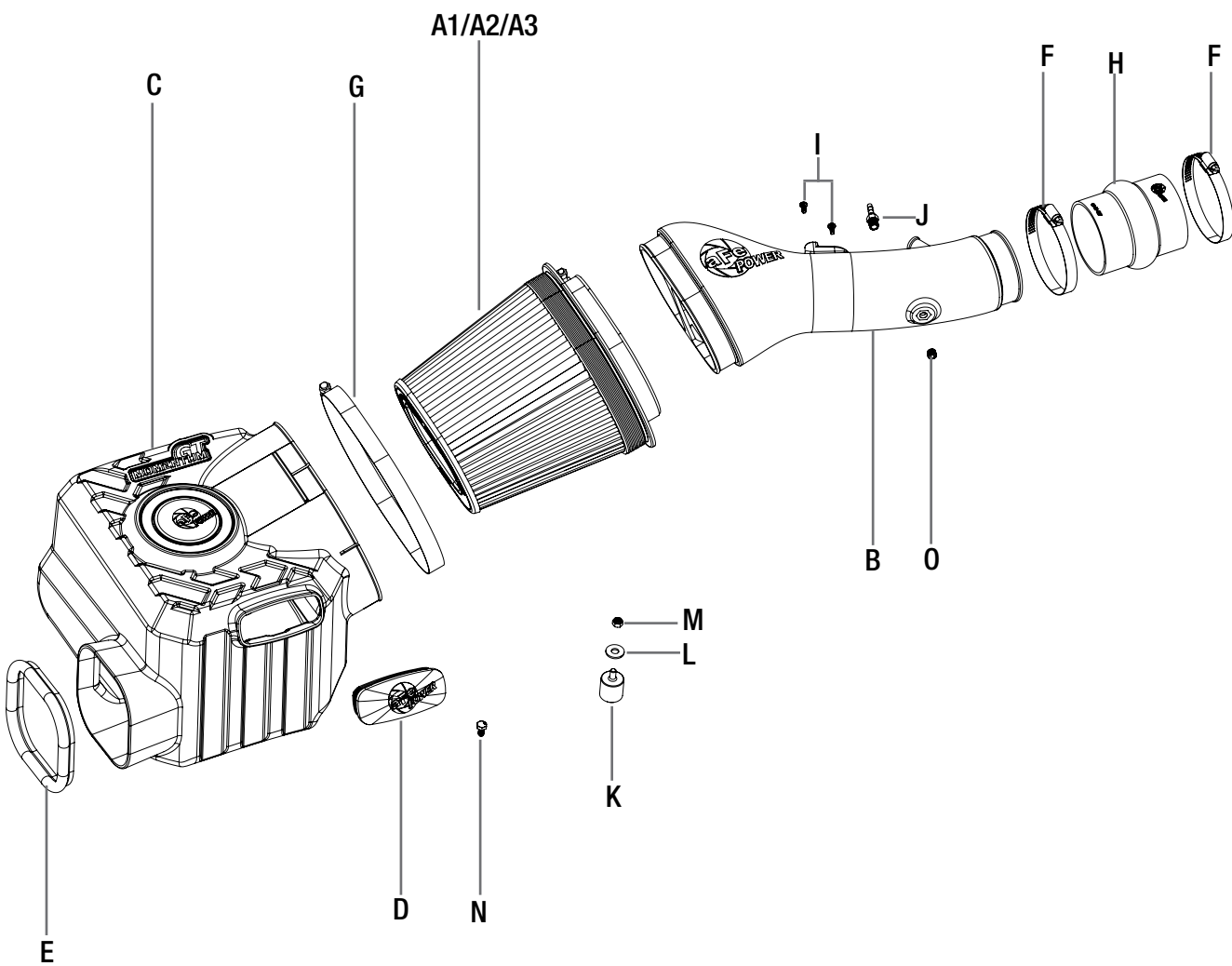

**Figure A****Refer to Figure A for Steps 1-2**

Step 1: Using a 10mm nut driver, loosen the stock clamps ① at the throttle body and OE airbox.

Step 2: Disconnect the two vent hoses ② from the stock intake tube.



Figure B

Refer to Figure B for Step 3

Step 3: Disconnect the Mass Airflow sensor (3) and disengage the wire clips (4) from the stock airbox.



Figure C

Refer to Figure C for Step 4

Step 4: Disengage the four clips (5) on the OE airbox and remove the top and filter. Set aside.

**Refer to Figure D for Step 5**

Step 5: Using a 12mm socket and extension, remove the three screws ⑥ holding the stock airbox and remove. Retain screws for later use.

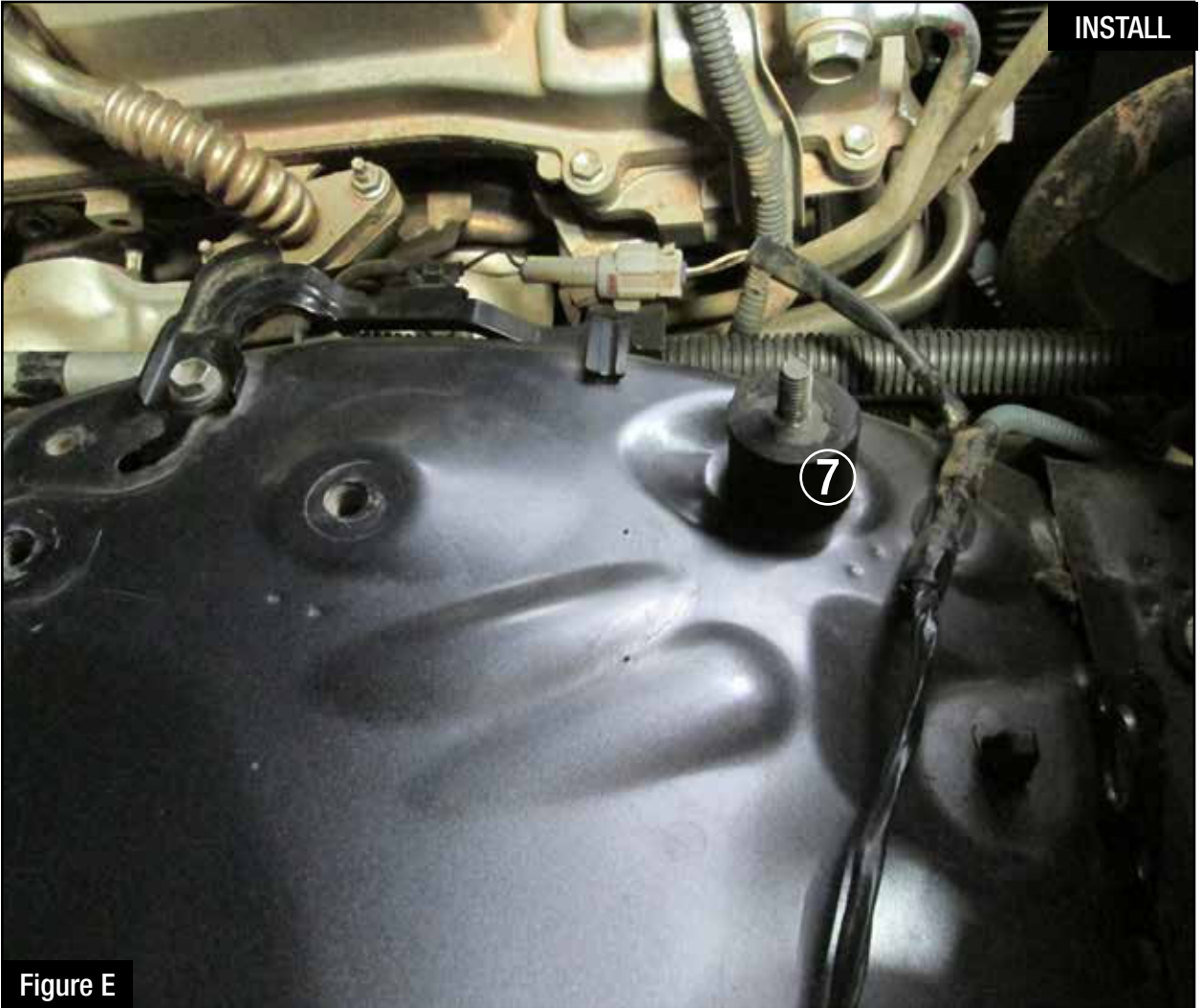

Figure E

Refer to Figure E for Step 6

Step 6: Install the supplied M8 rubber isolation mount (7) into the front-most threaded hole. Hand tighten only.



Figure F

Refer to Figure F for Step 7

Step 7: Install the supplied trim seal onto the aFe airbox. Trim to fit.



Figure G

Refer to Figure G for Step 8

Step 8: Remove and transfer two steel sleeves and two rubber grommets (8) from the stock airbox to the Momentum housing in the rear most mounting points.

**Figure H****Refer to Figure H for Step 9**

Step 9: Place the aFe airbox into the vehicle and secure using one of the 12mm bolts removed in Step 5 in the left-most mounting location (9). Use the supplied M8 screw in the right-rear mounting location (10) and tighten using a 12mm socket. Using the supplied M8 nut and washer, tighten down the airbox onto the isolation mount (11) using a 13mm socket and driver.



Figure I

Refer to Figure I for Step 10

Step 10: Install the supplied large T-bolt clamp (12) onto the airbox and slide the air filter into the airbox. Do not tighten the clamps at this time.



Figure J

Refer to Figure J for Steps 11-13

- Step 11: Remove the MAF sensor (13) from the OE airbox using a #1 Philips head screwdriver and reinstall into the aFe intake tube using the supplied T20 Torx screws.
- Step 12: Install the brass hose fitting (14) in the aFe intake tube near the MAF sensor and tighten using an 11mm wrench or socket.
- Step 13: Install the 1/8" NPT plug (15) into the fitting on the front of the aFe intake tube and tighten using a 3/16" Allen key. (This fitting is included for optional methanol injection).



Figure K

Refer to Figure K for Step 14

Step 14: Install the supplied coupler and clamp (16) onto the throttle body and tighten the clamp. Place the remaining clamp on the coupler, but do not tighten at this time.



Figure L

Refer to Figure L for Steps 15-16

- Step 15: Install the intake tube into the vehicle by sliding the tube into the coupling on the throttle body first, then into the filter.
- Step 16: Connect the crank case vent hose (17) to the aFe intake tube, and connect the 5/32" vacuum hose (18) to the aFe intake tube. Reconnect the MAF sensor (19). Tighten all clamps using an 11mm deep socket and driver. (As shown in picture)

**Figure M****Refer to Figure M for Step 17**

Step 17: Use the provided plug (20) to close the additional air inlet if you want to completely seal the airbox. Best performance gains are obtained without the plug. Check that all components are tight and secure. Your installation is now complete. Thank you for choosing aFe Power!

NOTE: Check all bolts, clamps, and connectors after 100-200 miles.

Page left blank intentionally



Page left blank intentionally

Page left blank intentionally

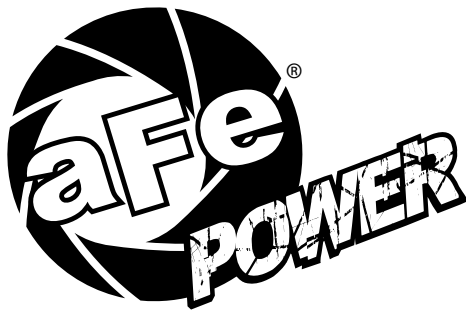

advanced FLOW engineering, inc.