

advanced FLOW engineering

Instruction Manual P/N: 51-76101 and 54-76101 Momentum GT

Make: **NISSAN** Model: **TITAN** Year: **2004-2015** Engine: **V8-5.6L**



- Please read the entire instruction manual before proceeding.
- Ensure all components listed are present.
- If you are missing any of the components, call customer support at 951-493-7100.
- Ensure you have all necessary tools before proceeding.
- Do not attempt to work on your vehicle when the engine is hot.
- Disconnect the negative battery terminal before proceeding.
- Retain factory parts for future use.

Label	Qty.	Description	Part Number
A	1	Air Filter (Pro DRY S)	21-91062 (51-76101)
B	1	Air Filter (Pro-5R)	24-91062 (54-76101)
C	1	Tube	05-76101B1
D	1	Housing	05-76101B2
E	1	Clamp, T-Bolt, (7-5/16"-7-5/8") ss	03-50290
F	1	Clamp, T-Bolt, (5-5/16"-5-5/8") ss	03-50291
G	2	Clamp, 052 (2-13/16"-3-3/4")	03-50008
H	1	Coupler Reducer	05-01276
I	1	Plug	05-01202

Tools needed: 8mm Nut driver, 8mm deep socket-wrench, 10 mm Nut driver, Standard pliers or channel locks, Phillips head screwdriver.

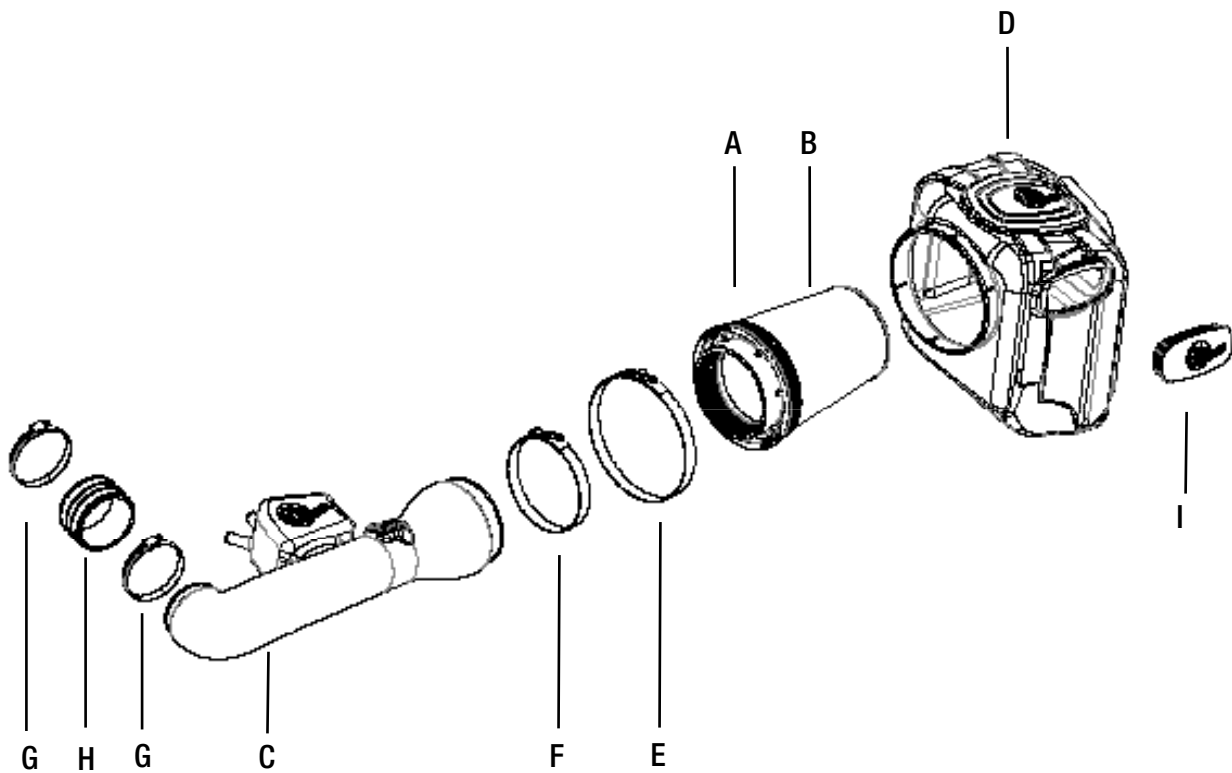

**Figure A****Refer to Figure A for Steps 1-2**

Step 1: Using a 10mm nut driver, remove the two bolts on the engine cover and the bolt on the factory air box tab. Save each for reuse later ①.

Step 2: Remove the factory engine cover by holding the sides and pulling straight up.



Figure B

Refer to Figure B for Steps 3-7

Step 3: Unplug the mass air flow (MAF) sensor (2).

Step 4: Unclip the wiring from the tab on the housing (needle nose pliers work best) (3).

Step 5: Disconnect the 2 crank case vent (CCV) hoses from the factory tube (4).

Step 6: Using an 8mm nut driver, loosen the band clamp on the tube at the throttle body (5).

Step 7: Remove the factory intake system.

**Figure C****Refer to Figure C for Steps 8-9**

Step 8: Using a Phillips screwdriver, unscrew and carefully remove the MAF sensor. Save screws and MAF sensor for reuse later (6).

Step 9: Push the metal sleeve through the rubber mounting grommet and then remove the grommet. Save both for reuse later (7).



Figure D

Refer to Figure D for Step 10

Step 10: Remove the factory rubber grommets from the bottom of the air box. Save for reuse later (8).



Figure E

Refer to Figure E for Steps 11-12

Step 11: Reinstall the 2 larger factory rubber grommets onto the bottom of the aFe housing as shown **⑨**.

Step 12: Reinstall the smaller factory rubber grommet in the tab on the aFe housing and then push the metal sleeve up from the bottom through the rubber grommet **⑩**.



Figure F

Refer to Figure F for Steps 13-15

- Step 13: Insert the MAF sensor into the aFe tube and securely screw it down using the 2 screws you saved earlier and a Phillips screwdriver (11).
- Step 14: Slip the reducer coupling (larger inner diameter) over the tube as shown. Slide one of the 3" band clamps over the coupling and tighten. Slip the other 3" band clamp over the coupling but do not tighten (12).
- Step 15: Using the smaller T-bolt clamp, secure the filter to the housing as shown and tighten using your 8mm deep socket. Do not overtighten (13).

**Figure G****Refer to Figure G for Steps 16-18**

- Step 16: Install the aFe housing by lining up the rubber grommets with the metal studs pointing up from the inner fender and firmly push down.
- Step 17: Slip the large T-bolt clamp onto the housing as shown but do not tighten yet.
- Step 18: Using your 10mm nut driver and the bolt you removed previously, tighten down the nut to secure the housing in place (14).

**Figure H****Refer to Figure H for Steps 19-20**

Step 19: Insert the aFe filter-tube assembly into the housing and slip the coupling over the throttle body and tighten.

Step 20: Using your 8mm deep socket tighten the large t-bolt clamp. Do not overtighten. Reattach the two CCV hoses as shown. Plug back in the MAF sensor (15).

**Figure I****Refer to Figure I for Step 21**

Step 21: Reinstall the factory engine cover and two bolts previously removing using your 10mm nut driver (16).

*Verify all connections are secure 100-200 miles after installation

Note: Place enclosed CARB EO sticker on or near the device on a smooth, clean surface. Eo identification label is required to pass the smog inspection.

Page left blank intentionally



Pro DRY S Air Filter



P/N: 21-91062

Pro 5R Air Filter



P/N: 24-91062

Pro DRY S Restore Kit



P/N: 90-59999

Blue Squeeze Restore Kit



P/N: 90-50501

Blue Aerosol Restore Kit



P/N: 90-50001

Air Filter



P/N: 30-10116

aFe Cat-Back Exhaust



P/N: 49-46102

aFe Throttle Body Spacer



P/N: 46-36001

Oil Filter



P/N: 44-LF016

To purchase any of the items above, view airflow charts, dyno graphs, photos, and video; please go to aFepower.com.

Warranty

General Terms:

- aFe warrants their products to be free from manufacturer's defects due to workmanship and material.
- This warranty applies only to the original purchaser of the product and is nontransferable.
- Proof of purchase of the aFe product is required for all warranty claims.
- Warranty is valid provided aFe instructions for installation and/or cleaning were properly followed.
- Proper maintenance with regular inspections of product is required to insure warranty coverage.
- Damage due to improper installation, abuse, unauthorized repair or alteration is not warranted.
- Incidental or consequential damages or cost, including installation and removal of part, incurred due to failure of aFe product is not covered under this warranty.
- All warranty is limited to the repair and/or replacement of the aFe part. To request Return Goods Authorization ("RGA"), email RGA@afepower.com or call (951)493-7100. Upon receipt of the RGA, you must return the product to the address provided in the RGA, freight prepaid and accompanied with a dated proof of purchase and the RGA. Upon receipt of the defective product and upon verification of proof of purchase, aFe will either repair or replace the defective product within a reasonable time, not to exceed thirty days.

Product Category	P/N Prefix	Warranty duration
Direct OE Replacement Filters	10, 11, 30, 31, 71, 73	Life of the vehicle
Racing Filters	18	1 year
Universal	21, 24, 72	2 years
Air Intake Systems	50, 51, 54, 55, 75	2 years
Exhaust Systems	49	2 years
Intercoolers & Intercooler Tubes	46-2	2 years
Intake Manifolds	46-1	2 years
Differential Cover	46-7	Life of the vehicle
Exhaust Manifolds	46	2 years
Throttle Body Spacers	46-3	2 years
Fluid Filters	44	90 days
Pre-Filters	28	2 years
Heavy Duty OE Replacement	70	2 years
PowerSports OE Replacement	81, 87	2 years
PowerSports Intake Systems	85	2 years

No other warranty expressed or implied applies nor is any person or advanced FLOW engineering authorized to assume any other warranty. Some States do not allow the exclusion or limitation of incidental or consequential damages or do not allow limitations on how long an implied warranty lasts, so the above limitations or exclusions may not apply to you. This warranty gives you specific legal rights, and you may also have other rights which vary from State to State.

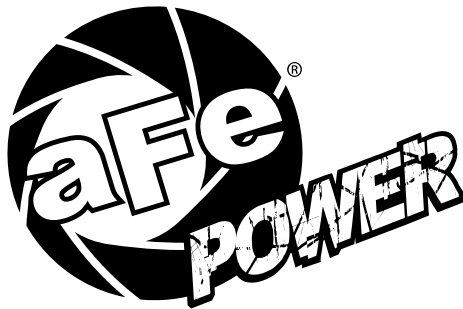

advanced FLOW engineering, inc.
252 Granite Street Corona, CA 92879
TEL: 951.493.7155 • TECH: 951.493.7100
E-Mail: Tech@aFepower.com