

GT **MOMENTUM™**

advanced FLOW engineering

Momentum GT Cold Air Intake System

Instruction Manual P/N: 50-70032D / 50-70032R

Make: Audi

Model: A4 (B9)

Year: 2017-2019

Engine: I4-2.0L (t) 45 TFSI



- Please read the entire instruction manual before proceeding.
- Ensure all components listed are present.
- If you are missing any of the components, call customer support at 951-493-7100.
- Ensure you have all necessary tools before proceeding.
- Do not attempt to work on your vehicle when the engine is hot.
- Disconnect the negative battery terminal before proceeding.
- Retain factory parts for future use.

Label	Qty.	Description	Part Number
A1	1	Air Filter (Pro 5R)	24-91144
A2	1	Air Filter (Pro DRY S)	21-91144
B	1	Tube	05-5070032B1
C	1	Housing	05-5070032B2
D	1	Inlet Trim, Silicone	05-01516
E	1	Clamp, 044 (2-5/16" – 3-1/4")	03-50019

Installation will require the following tools:

T-25 Torx driver, 7mm socket, 8mm socket and driver.

Emissions Disclaimer: This product is not currently CARB exempt and is not available for purchase in California or for use on any vehicle registered with the California Department of Motor Vehicles.

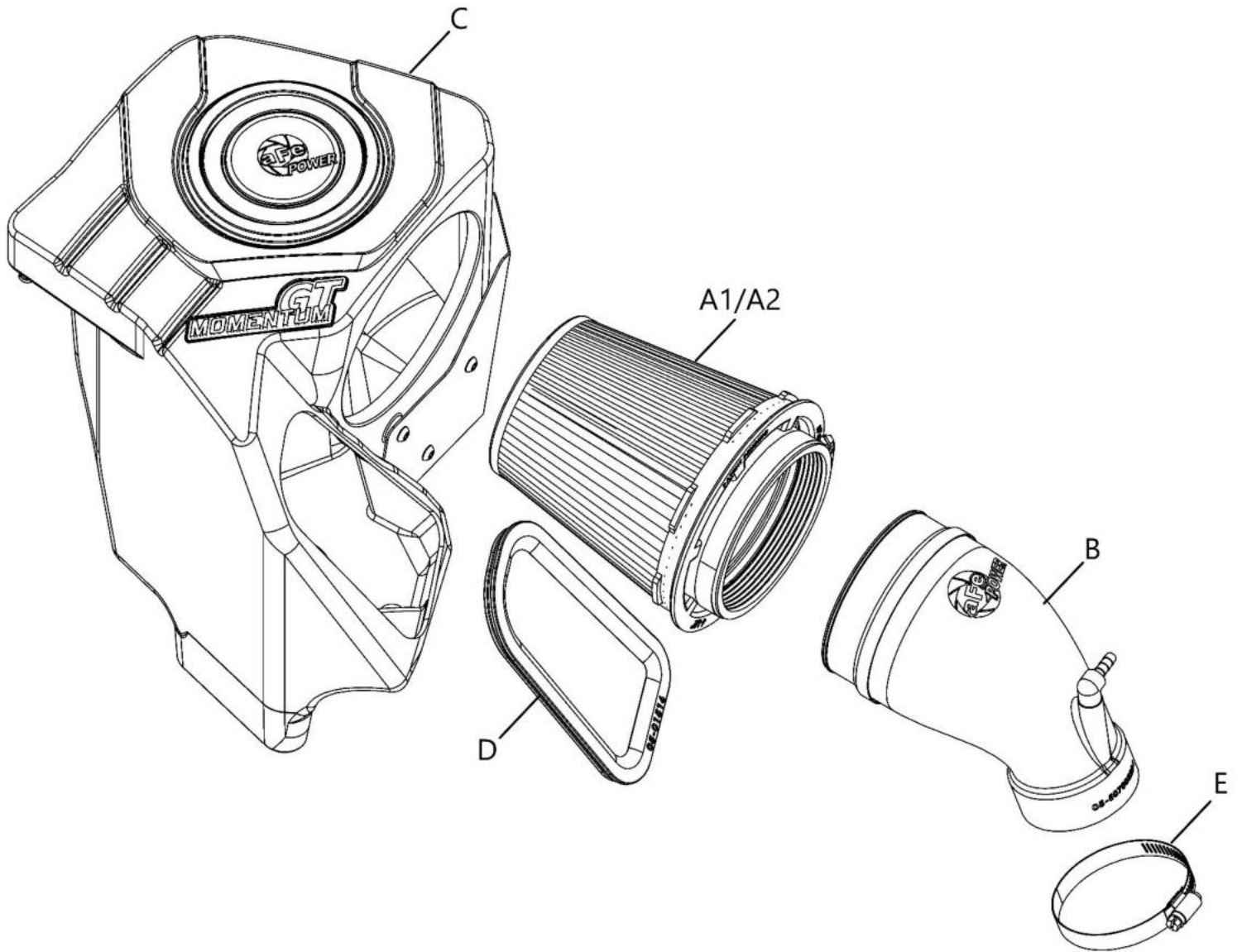

**Figure A****Refer to Figure A for Steps 1-2**

Step 1: Remove the hood latch (1) by pressing in on the back side until it disengages, then lifting straight up.

Step 2: Remove the cowl (2) by pulling gently up on the front edges to disengage the clips, then pulling straight forward.

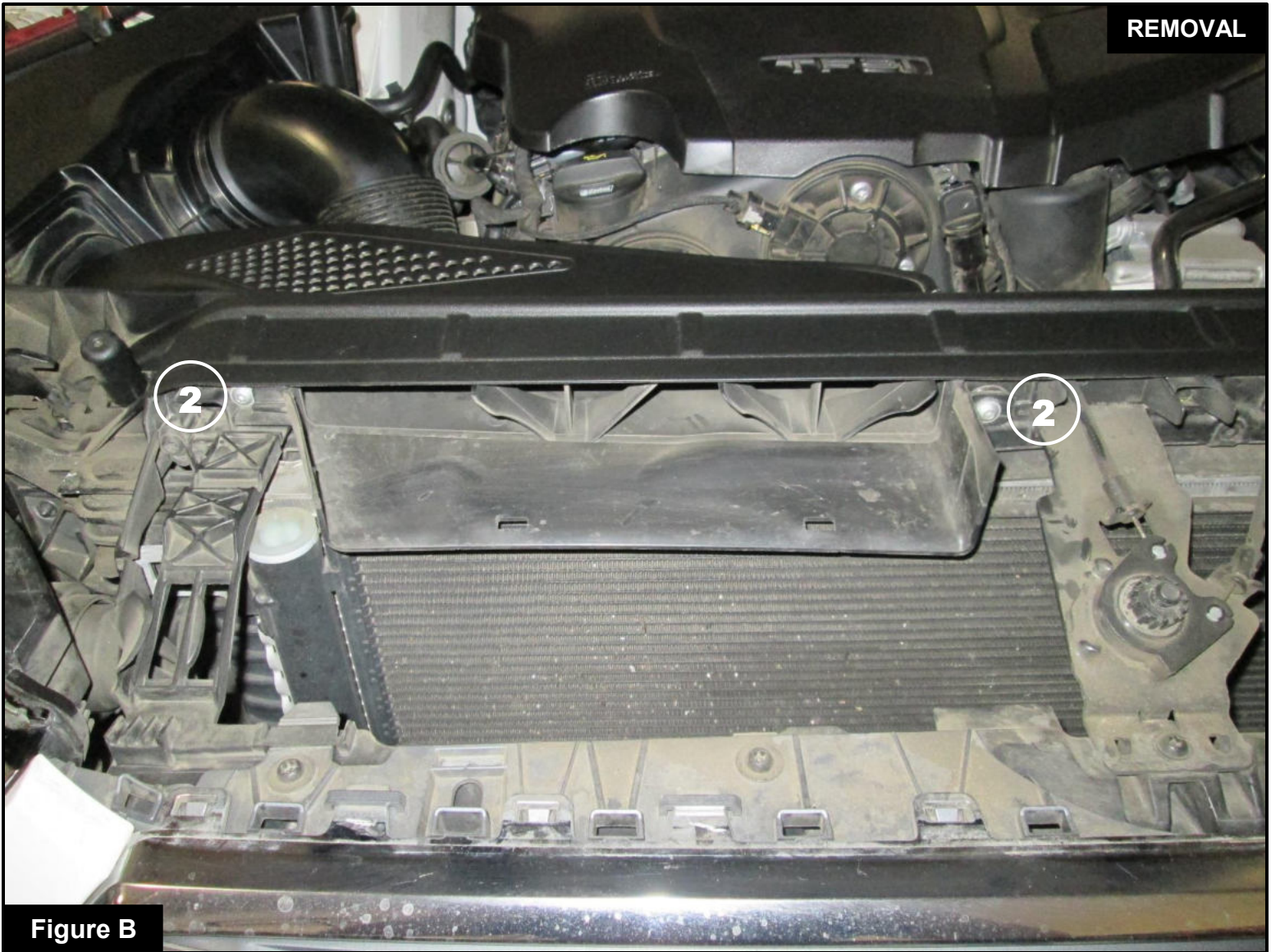
**Figure B****Refer to Figure B for Step 3**

Step 3: Using a T25 Torx driver, remove the two screws (2) securing the stock inlet scoop and set them aside. Remove the scoop from the vehicle.

**Figure C****Refer to Figure C for Step 4**

Step 4: Disconnect the breather hose (3) from the stock intake tube, then loosen the two clamps (4) using a 7mm socket and driver. Remove the intake tube from the vehicle.

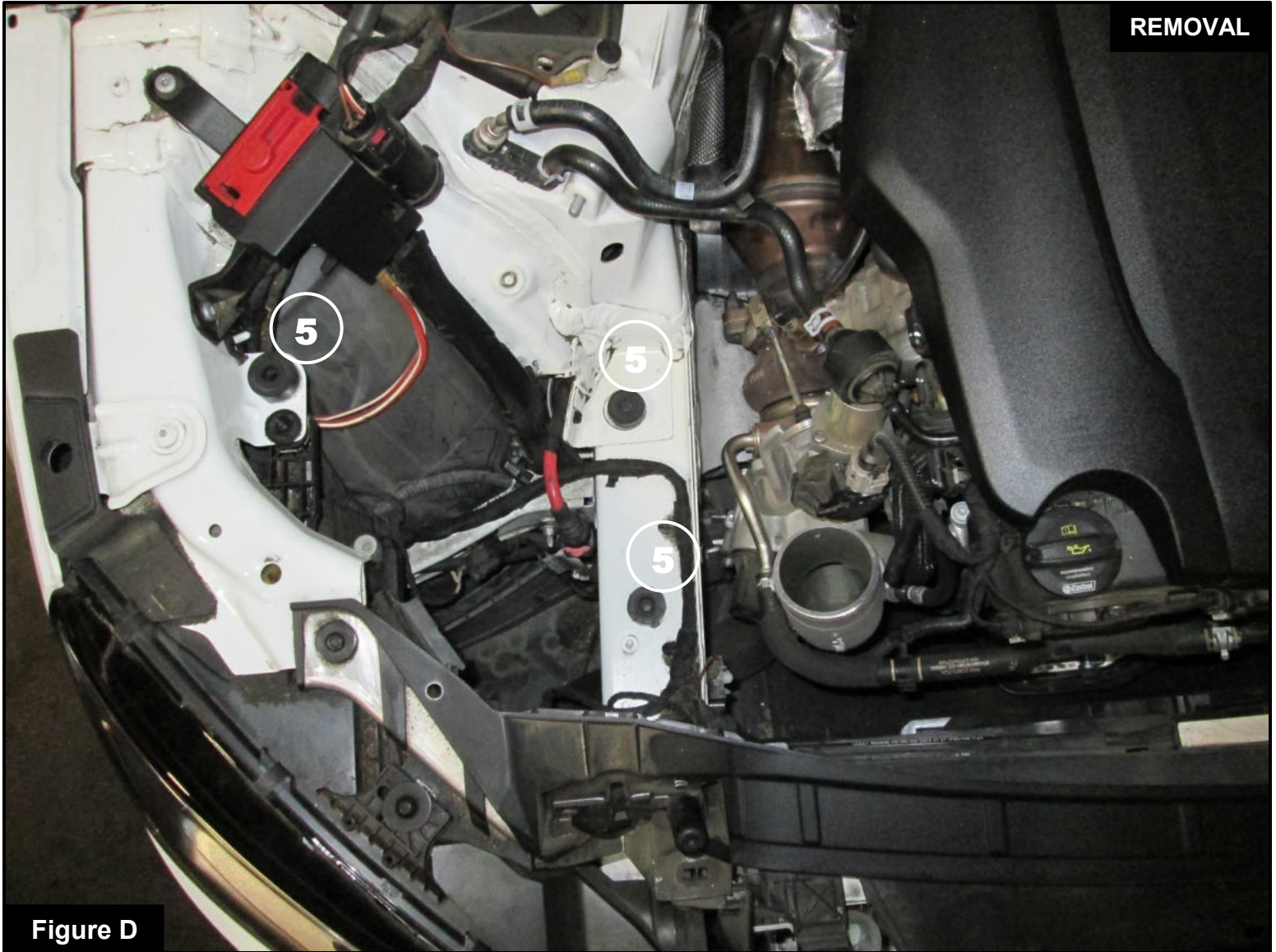
**Figure D****Refer to Figure D for Steps 5-6**

Step 5: Remove the stock filter housing by pulling directly upwards until it disengages from the three mounting grommets⑤.

Step 6: If the stock grommets come out attached to the stock housing, remove them and reinstall in their proper places in the vehicle.



Figure E

Refer to Figure E for Step 7

Step 7: Install the supplied silicone inlet trim ⑥ into the opening on your aFe Power housing.



Figure F

Refer to Figure F for Step 8

Step 8: Install your aFe Power housing (7) into the vehicle ensuring it is properly seated in all three mounting grommets.



Figure G

Refer to Figure G for Step 9

Step 9: Install your aFe Power air filter and clamp ⑧ into the housing in the vehicle.

**Figure H****Refer to Figure H for Steps 10-11**

Step 10: Install your aFe Power silicone intake tube and clamp (9) first onto the turbocharger inlet, then into the air filter. Tighten both clamps using an 8mm socket and driver.

Step 11: Reconnect the breather hose (10) to the fitting on your aFe Power intake tube.

**Figure I****Refer to Figure I for Step 12**

Step 12: Reinstall the stock inlet scoop (11) into the vehicle by sliding the smaller end into the opening on your aFe Power housing, then securing using the two screws (12) removed in step #3. Tighten both screws using a T25 Torx driver.



Figure J

Refer to Figure J for Steps 13-14

Step 13: Reinstall the stock radiator cowl (13) by sliding the top end into place, then securing the clips along the front edge. Reattach the hood latch (14).

Step 14: Your installation is now complete. Thank you for choosing aFe POWER!

NOTE: Check all bolts, clamps, and connectors after 100-200 miles.



Pro DRY S Air Filter



P/N: 21-91144

Pro 5R Air Filter



P/N: 23-91144

Pro DRY S Restore Kit



P/N: 90-59999

Pro 5R Restore Kit



P/N: 90-50501

Cat-Back Exhaust System



P/N: 49-36420-B (Blk Tips)

P/N: 49-36420-P (Polished)

P/N: 49-36420-C (Carbon)

Axle-Back Exhaust System



P/N: 49-36419-B (Blk Tips)

P/N: 49-36419-P (Polished)

P/N: 49-36419-C (Carbon)

Pre-Filter



P/N: 28-10113

Tactical Backpack



P/N: 40-33205-B

To purchase any of the items above, view airflow charts, dyno graphs, photos, and video; please go to aFepower.com.



Warranty

General Terms:

- aFe warrants their products to be free from manufacturer's defects due to workmanship and material.
- This warranty applies only to the original purchaser of the product and is non-transferrable.
- Proof of purchase of the aFe product is required for all warranty claims.
- Warranty is valid provided aFe instructions for installation and/or cleaning were properly followed.
- Proper maintenance with regular inspections of product is required to insure warranty coverage.
- Damage due to improper installation, abuse, unauthorized repair or alteration is not warranted.
- Incidental or consequential damages or cost, including installation and removal of part, incurred due to failure of aFe product is not covered under this warranty.
- All warranty is limited to the repair and/or replacement of the aFe part. To request Return Goods Authorization ("RGA"), email RGA@afepower.com or call (951)493-7100. Upon receipt of the RGA, you must return the product to the address provided in the RGA, freight prepaid and accompanied with a dated proof of purchase and the RGA. Upon receipt of the defective product and upon verification of proof of purchase, aFe will either repair or replace the defective product within a reasonable time, not to exceed thirty days.

Product Category	P/N Prefix	Warranty duration
Direct OE Replacement Filters	10, 11, 30, 31, 71, 73	Life of the vehicle
Racing Filters	18	1 year
Universal	21, 23, 24, 72, TF	2 years
Air Intake Systems	50, 51, 53, 54, 55, 58, 75, TR, TA, TL, TM	2 years
Exhaust Systems	49	2 years
Intercoolers & Intercooler Tubes	46-2	2 years
Intake Manifolds	46-1	2 years
Differential Cover	46-7	Life of the vehicle
Exhaust Manifolds	46	2 years
Throttle Body Spacers	46-3	2 years
Turbochargers	46-6	2 years*
Fluid Filters	44	90 days
Pre-Filters	28	2 years
Heavy Duty OE Replacement	70	2 years
PowerSports OE Replacement	81, 87	2 years
PowerSports Intake Systems	85	2 years

No other warranty expressed or implied applies nor is any person or advanced FLOW engineering authorized to assume any other warranty. Some States do not allow the exclusion or limitation of incidental or consequential damages or do not allow limitations on how long an implied warranty lasts, so the above limitations or exclusions may not apply to you. This warranty gives you specific legal rights, and you may also have other rights which vary from State to State.

*See turbocharger warranty for more info



advanced FLOW engineering, inc.

252 Granite Street Corona, CA 92879
TEL: 951.493.7100 • TECH: 951.493.7134
E-Mail: Tech@aFepower.com

P/N: 06-81305