

GT
MOMENTUM

advanced FLOW engineering

Momentum GT Cold Air Intake System

Instruction Manual

P/N: 50-70071D / 50-70071R

Make: Chevrolet

Model: Blazer

Year: 2019-2022

Engine: V6-3.6L

Make: GMC

Model: Acadia

Year: 2017-2022

Engine: V6-3.6L

Make: Cadillac

Model: XT5

Year: 2017-2022

Engine: V6-3.6L



- Please read the entire instruction manual before proceeding.
- Ensure all components listed are present.
- If you are missing any of the components, call customer support at 951-493-7185.
- Ensure you have all necessary tools before proceeding.
- Do not attempt to work on your vehicle when the engine is hot.
- Retain factory parts for future use.

Label	Qty.	Description	Part Number
A1	1	Air Filter (Pro 5R) for 50-70071R	24-91156
A2	1	Air Filter (Pro DRY S) for 50-70071D	21-91156
B	1	Tube	05-5070071B1
C	1	Housing	05-5070071B2
D	1	Coupling, Silicone Bellows Reducer	05-01694
E	1	Clamp, #048	03-50007
F	1	Clamp, #052	03-50008
H	1	Mini Clamp, #024	03-50093
I	2	MAF Sensor Screws, M4	03-50490
J	1	Silicone Plug	05-01429

Installation will require the following tools:

¼", 8mm, 10mm, & 11mm socket, extension, ratchet, cutting pliers, a T20 Torx-driver flat-head screwdriver

Emissions Disclaimer: This product is not currently CARB exempt and is not available for purchase in California or for use on any vehicle registered with the California Department of Motor Vehicles.

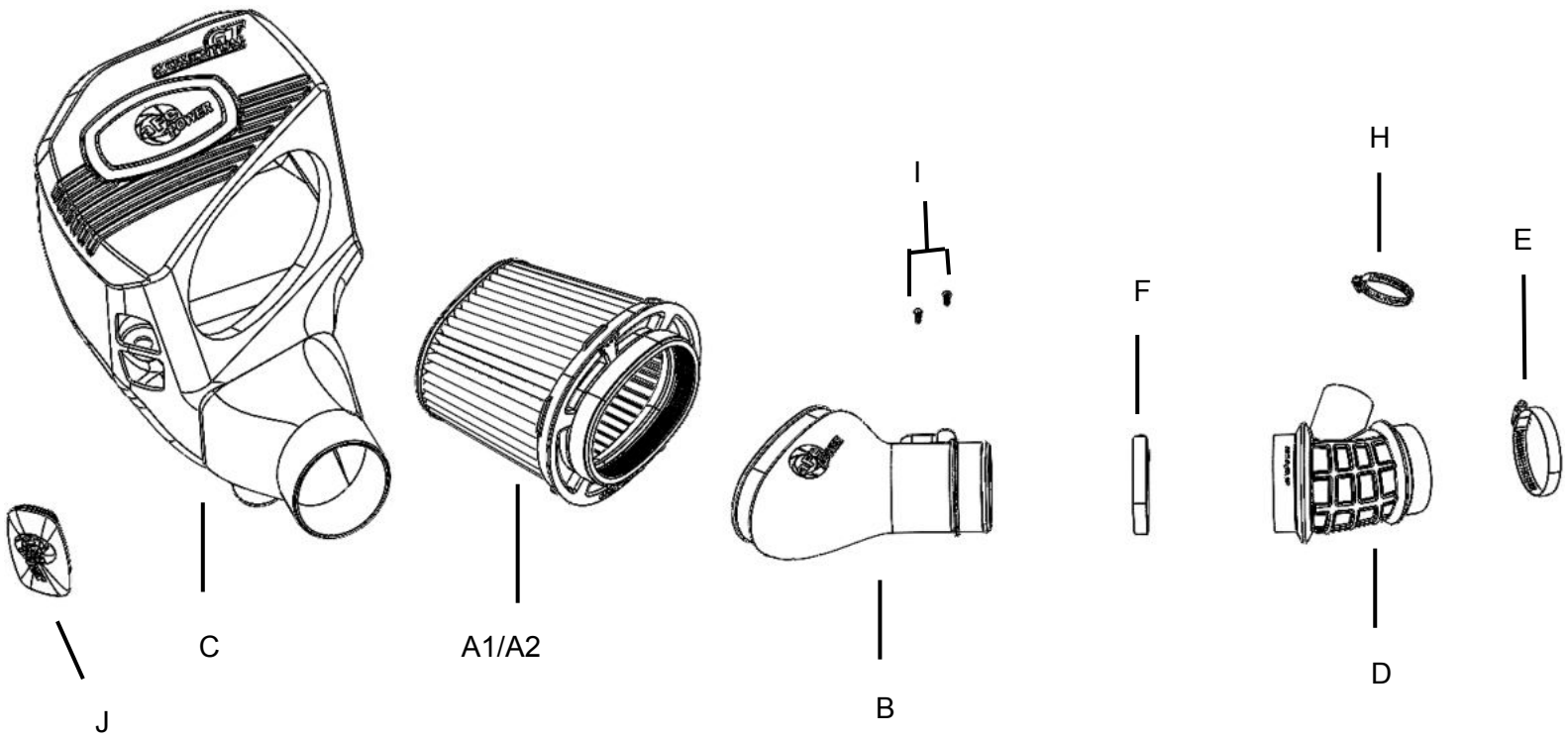

**Figure A****Refer to Figure A for Step 1**

Step 1: Disconnect the MAF sensor plug from the factory air intake by moving the red tab upwards and squeezing the plug on the top and bottom.

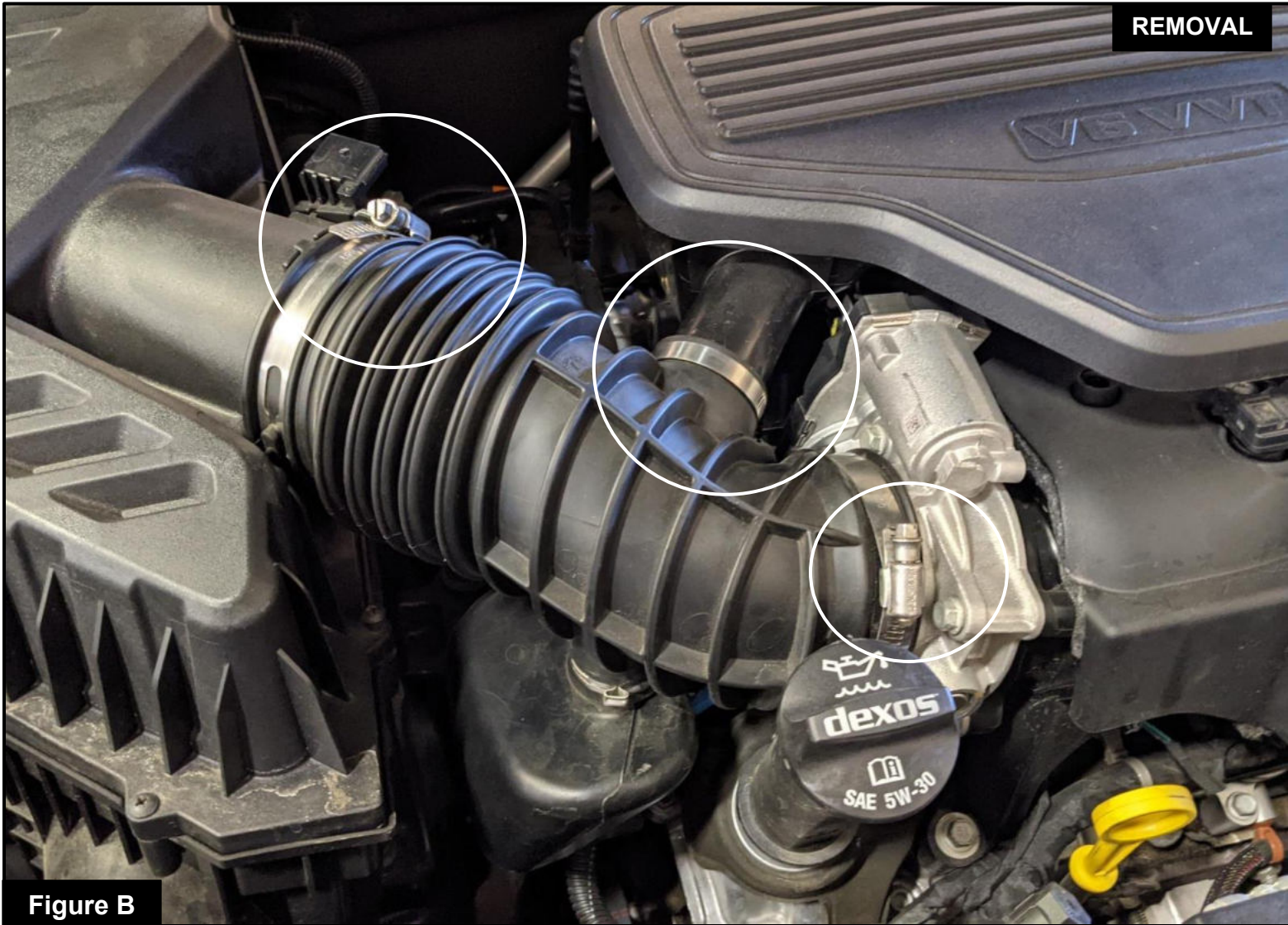

Figure B

Refer to Figure B for Steps 2-3

Step 2: Using 8mm nut driver or socket, loosen the worm clamp on the throttle body and the airbox.

Step 3: Remove the clamp going to the engine cover by snipping it with pliers. It will be replaced.

**Figure C****Refer to Figure C for Steps 4-5**

Step 4: Remove the factory tube by pulling it up, and towards the front of the vehicle.

Step 5: The factory airbox sits on 3 rubber grommets. Remove the factory airbox by gently, and firmly, pulling up on it.



Figure D

Refer to Figure D for Step 6

Step 6: Transfer the three mounting grommets from the bottom of the factory housing to the aFe POWER housing.

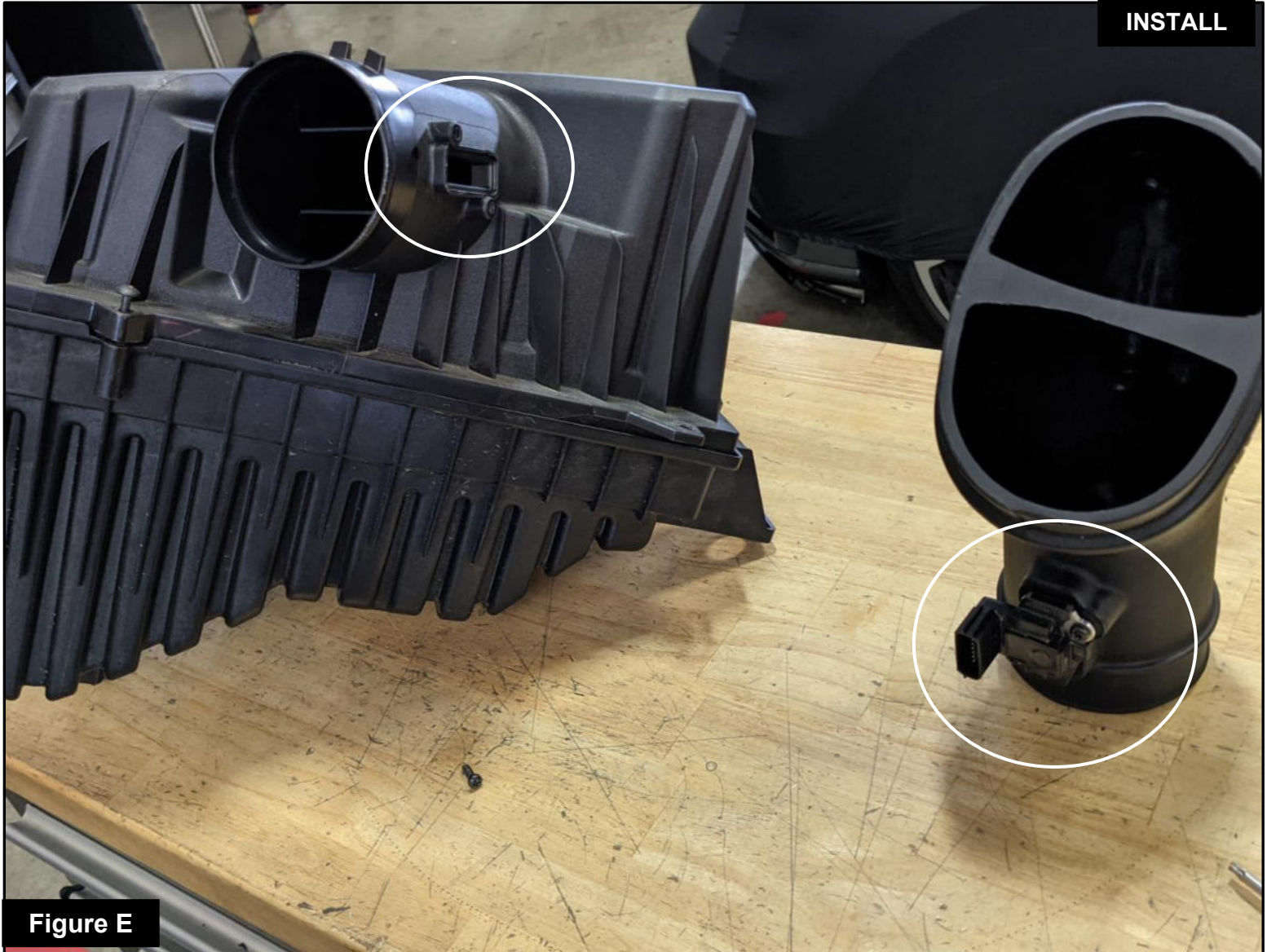

Figure E

Refer to Figure E for Steps 7-8

Step 7: Using the Torx driver, remove the MAF sensor from the factory airbox.

Step 8: Transfer the MAF sensor to the aFe POWER tube, using the provided M4 screws.



Refer to Figure F for Steps 9-10

Step 9: Install the AFEPOWER housing, aligning the inlet scoop and the 3 mounting pegs, and pushing it firmly down until it feels locked in place.

Step 10: Insert the air filter into the aFe POWER housing until it snaps into place.



Refer to Figure G for Steps 11-12

Step 11: Place the T-bolt clamp over the filter flange, but do not tighten it down yet.

Step 12: Insert the silicone coupling over the throttle body, using the #048 clamp. Slip the small port of the coupling over the engine cover port with the #024 mini clamp. Tighten the clamps to be snug.

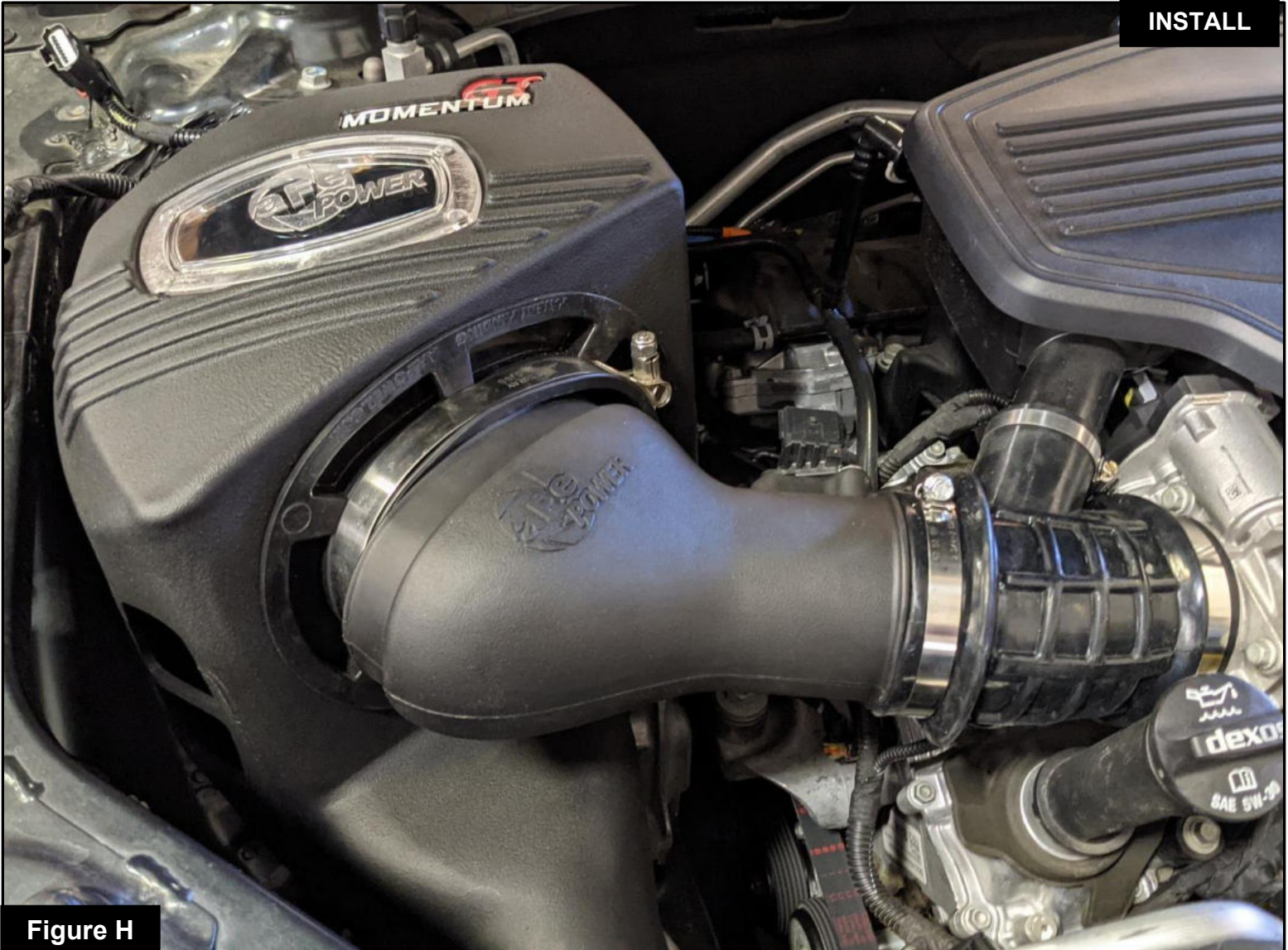
**Figure H****Refer to Figure H for Step 13-14**

Step 13: Slip the #052 clamp over the end of the coupler. Insert the aFe POWER tube into the silicone coupling. Tighten the #052 clamp onto the tube.

Step 14: Slip the oval end of the tube into the filter flange. Make sure the coupler and tube are aligned with the throttle body, engine cover port, and filter flange.

**Figure I****Refer to Figure I for Steps 15-16**

Step15: Tighten the T-bolt clamp over the filter flange

Step 16: Reconnect the sensor harness to the MAF sensor. Push in the red clip.



Figure J

Refer to Figure I for Step 17

Step 17: The kit includes an optional plug to close off the side auxillary air inlet. Install the plug if you wish to close off the side auxillary air inlet and only capture cold air from the front.

- Without the plug installed, the aFe POWER intake will capture the maximum air available. More airflow offers more power. Yet some of this air is picked up from inside the engine compartment and could be warmer air. Warmer air will affect the performance of the vehicle.
- The plug installed on the housing will block off any hot engine air entering the housing and make sure the coolest air available is directed into the engine, It will also reduce the noise of the intake.



Refer to Figure K for Steps 18-19

Step 18: Make sure all clamps and connections are secured. Your installation is now complete. Thank you for choosing aFe POWER!

NOTE: Check all screws, clamps, and connectors are secure after 100-200 miles.



Page left blank intentionally



advanced FLOW engineering, inc.

252 Granite Street Corona, CA 92879

<https://afepower.com/contact>