

MOMENTUM *GT*

advanced FLOW engineering Cold Air Intake System

Instruction Manual P/N: 50-70082D / 50-70082G / 50-70082R

Make: Ford

Model: Bronco

Year: 2021-2022

Engine: I4-2.3L (t)



9

- Please read the entire instruction manual before proceeding.
- Ensure all components listed are present.
- For technical support please call 951-493-7185.
- Ensure you have all necessary tools before proceeding.
- Do not attempt to work on your vehicle when the engine is hot.
- Retain factory parts for future use.

Label	Qty.	Description	Part Number
A1	1	Air Filter (Pro 5R)	20-91205R
A2	1	Air Filter (Pro DRY S)	20-91205D
A3	1	Air Filter (Pro GUARD7)	20-91205G
B	1	Intake Tube	05-5070082B1
C	1	Housing	05-5070082B2
D	2	Clamp, 044 (2-5/16" - 3-1/4")	03-50019
E	1	Coupling, Silicone	05-01732
F	2	Fitting, SAE 15.82 - 5/8" to 3/8" NPT	05-01339
G	1	Fitting, CCV Vacuum: (12.61" & 9.89")in, 7.8" out	05-01698
H	1	Grommet, Silicone; 05-01698 Fitting	03-50751
J	1	Fitting, Air Temp Sensor	05-01454
K	1	Grommet, Rubber	03-50167
M	1	Screw, Flange Hex Head: M6 x 1.00 x 1.25mm	03-50774
N	1	Isolation Mount, M6 Stud and Insert x 1/2"H	03-50664

Installation will require the following tools:

Panel clip remover, 7mm & 8mm nut driver, 10mm socket and driver, 20mm wrench or adjustable wrench, side cutter & tongue pliers, green size angled disconnect tool

Warranty Information available at <https://afepower.com/contact#warranty>

Emissions Disclaimer: This product is not currently CARB exempt and is not available for purchase in California or for use on any vehicle registered with the California Department of Motor Vehicles.

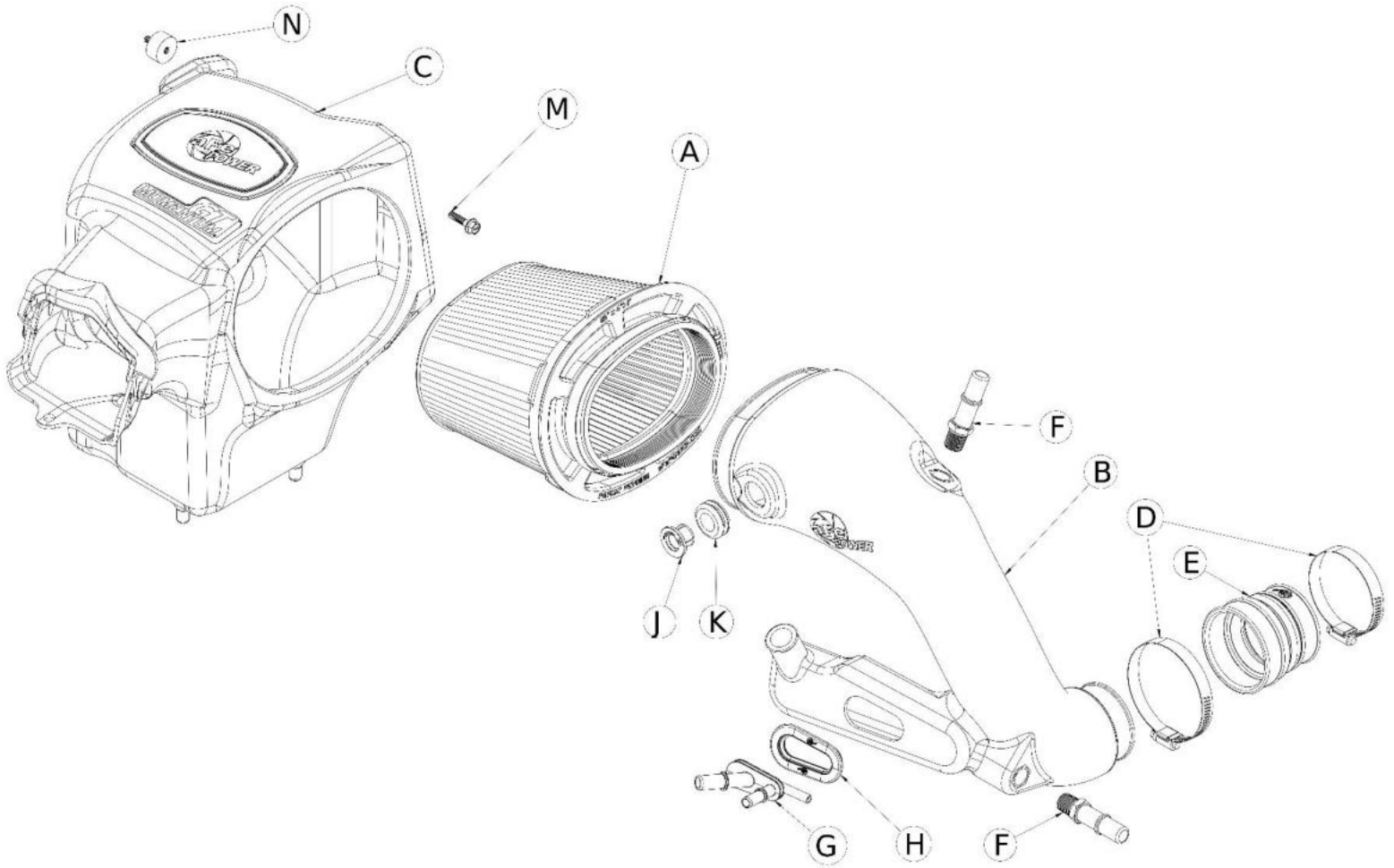



Refer to Figure A for Step 1

Step 1: Using a panel clip remover, remove the retainer clip ① holding the scoop duct. Remove the scoop duct and set it aside with the retainer clip.

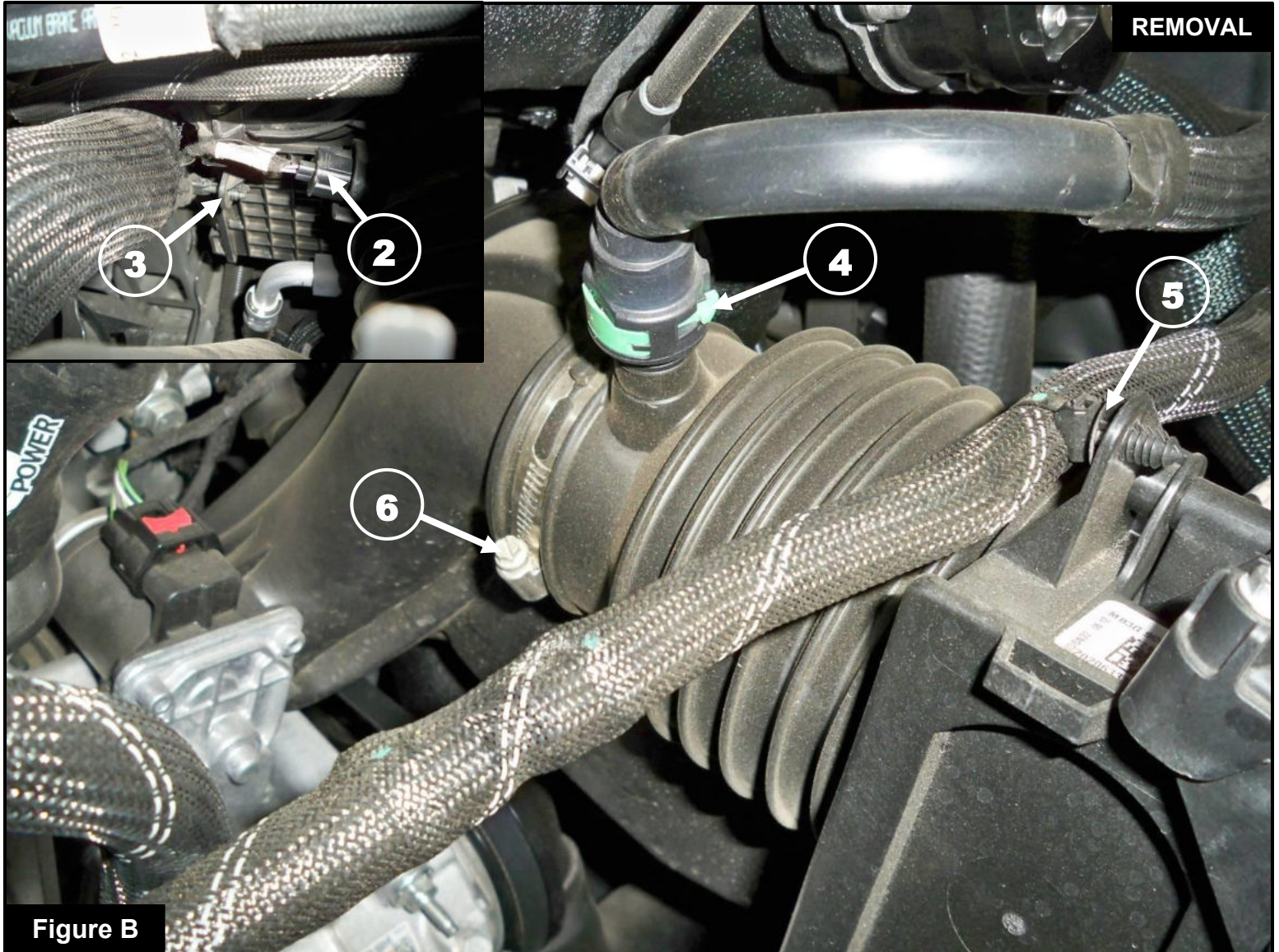

Figure B

Refer to Figure B for Steps 2-6

Step 2: Disconnect the IAT sensor electrical connector (2).

Step 3: Release the retainer clip (3) and position aside the wiring harness.

Step 4: Disconnect the quick release vent connector (4).

Step 5: Release the retainer clip (5) and position aside the coolant reservoir hose.

Step 6: Using a 7mm nut driver, loosen the clamp (6) at the factory intake tube. Detach intake tube from the factory airbox.

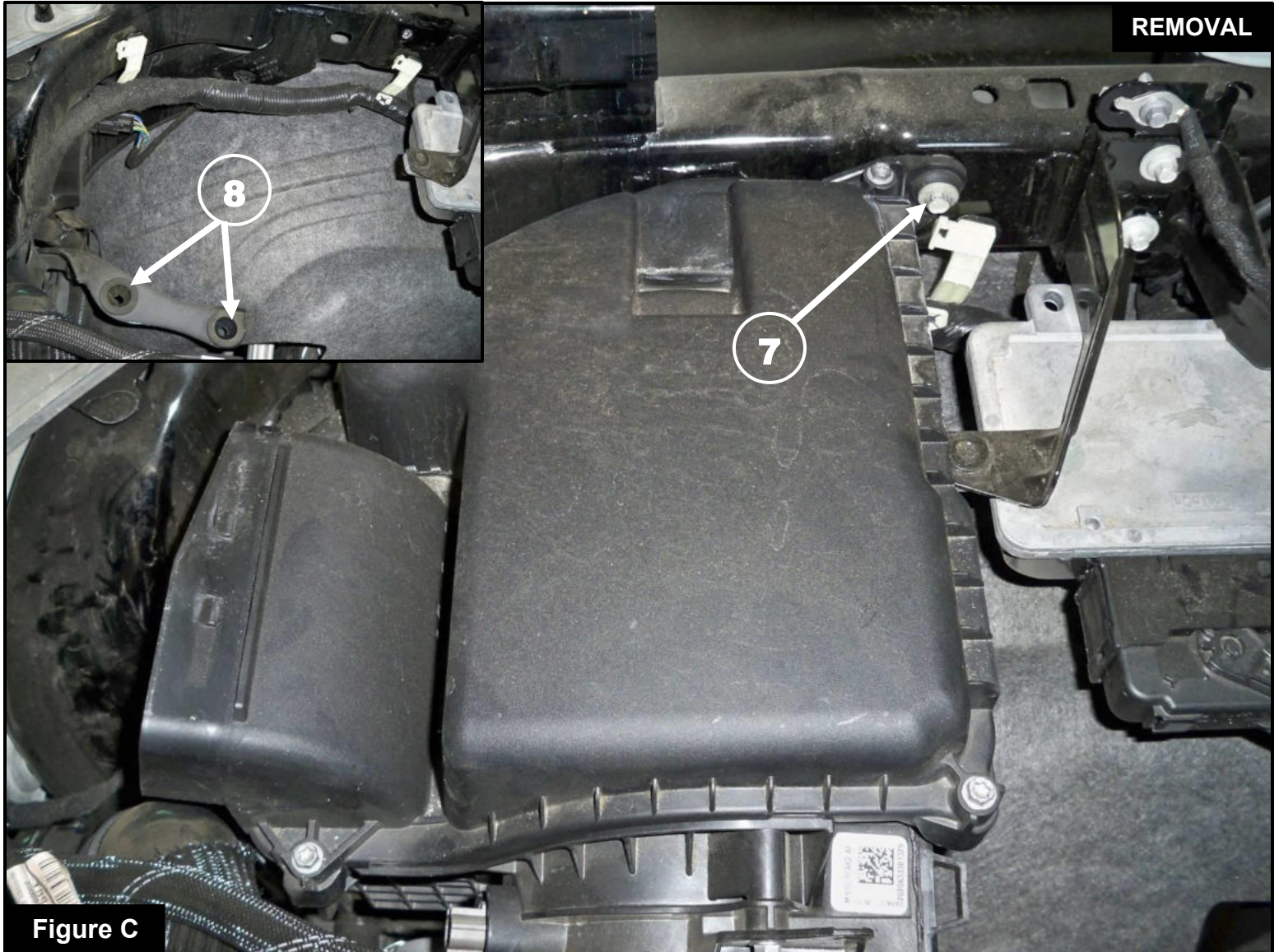
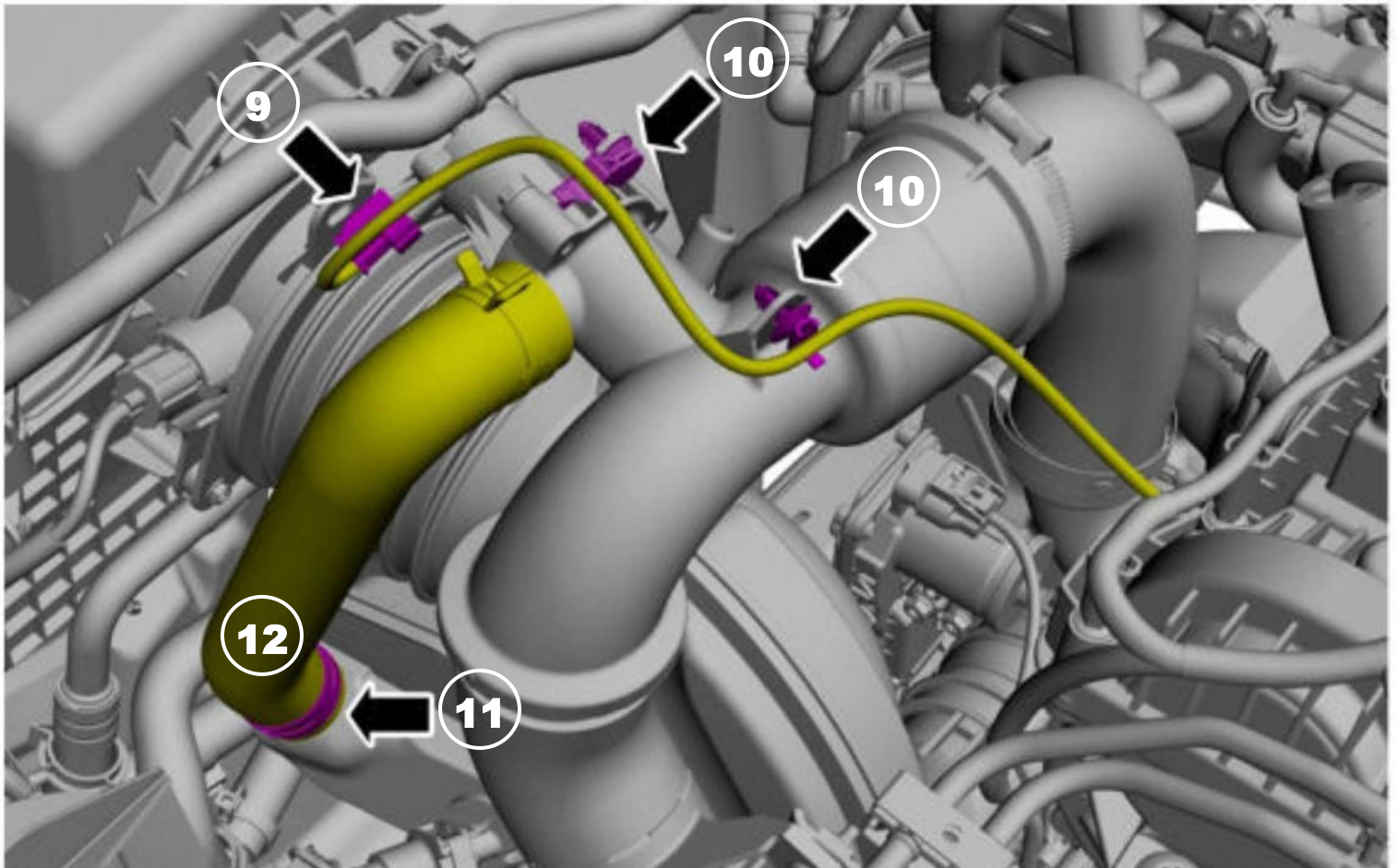

Figure C

Refer to Figure C for Steps 7-8

Step 7: Using a 10mm socket and driver, remove the screw (7) holding the factory airbox.

Step 8: Detach and remove the factory airbox from the isolators (8). If the isolators are pulled out and are stuck in the lower half of the factory airbox, remove them and insert them back on the mounting bracket.

Figure D
Refer to Figure D for Steps 9-10

Step 9: Disconnect the bypass valve electrical connector (9) and release the retainer clips (10).

Step 10: Using tongue pliers, loosen the clamp (11) and disconnect the bypass valve hose (12).

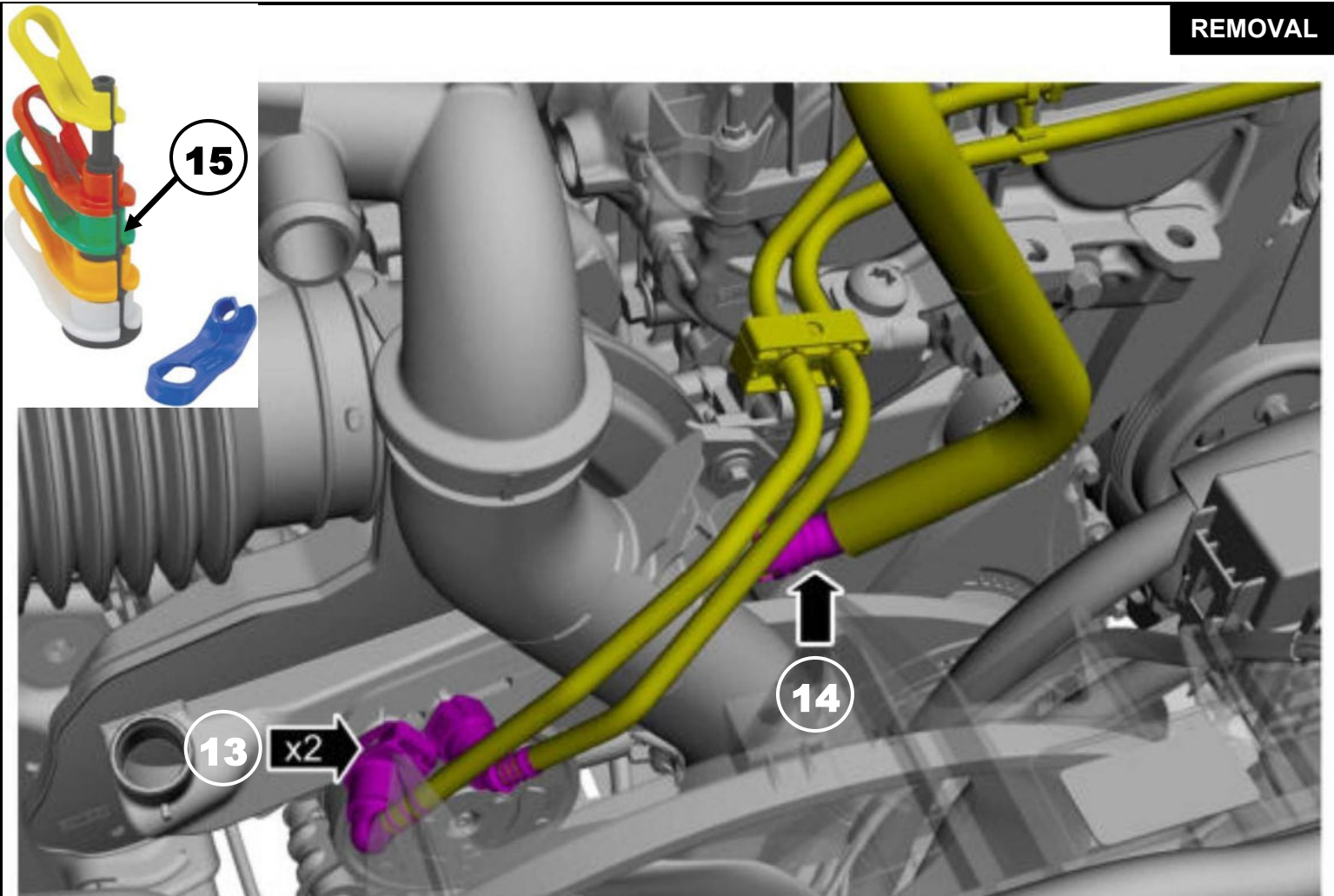
Figure E
Refer to Figure E for Steps 11-12

Step 11: Disconnect the quick release connectors (13) for the fuel vapor hoses and set aside.

Step 12: Disconnect the crankcase vent tube connector (14) by using a green size angled (15) disconnect tool as shown. If necessary, cut the lock tabs from the permanent connector (orange color locking clip) using side cutter pliers to remove. Replace the crankcase vent tube if the tabs were cut.

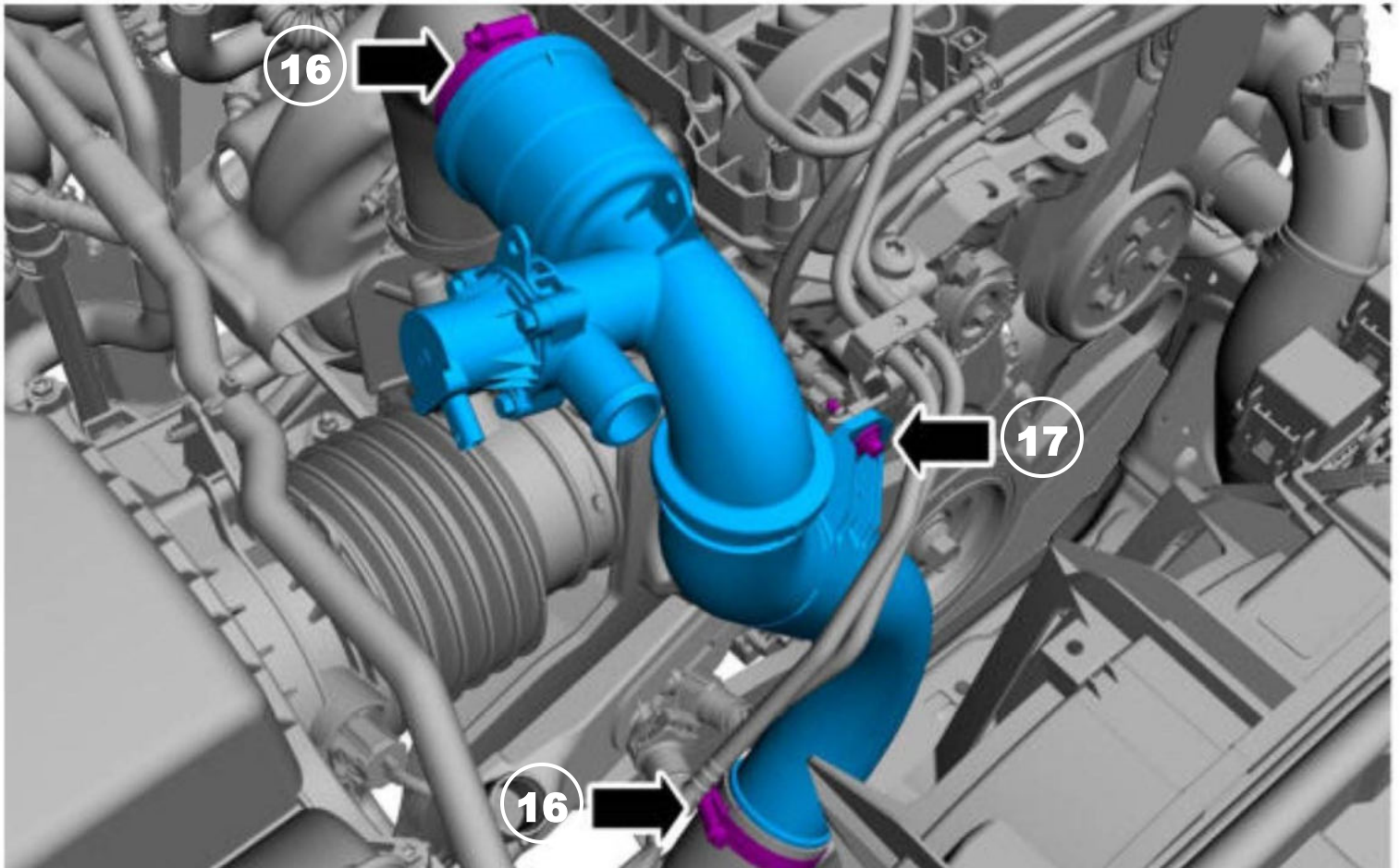
**Figure F****Refer to Figure F for Steps 13-14**

Step 13: Using a 7mm nut driver, loosen the CAC inlet pipe clamps (16).

Step 14: Using a 10mm socket and driver, remove the screw (17) holding the CAC inlet pipe. Remove the CAC inlet pipe.

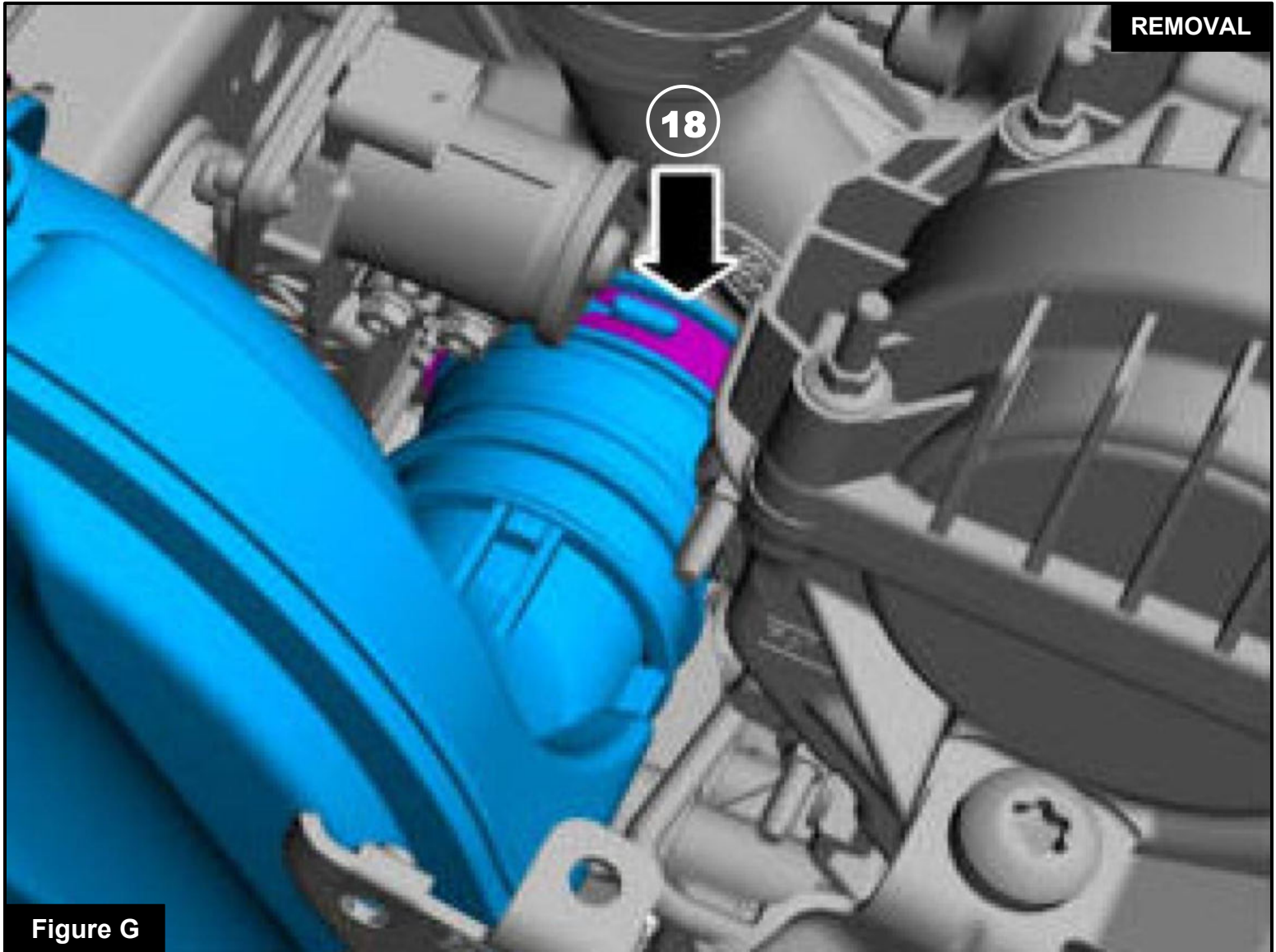
**Figure G****Refer to Figure G for Step 15**

Step 15: Using tongue pliers, loosen the clamp (18) at the turbo and remove the factory intake tube.

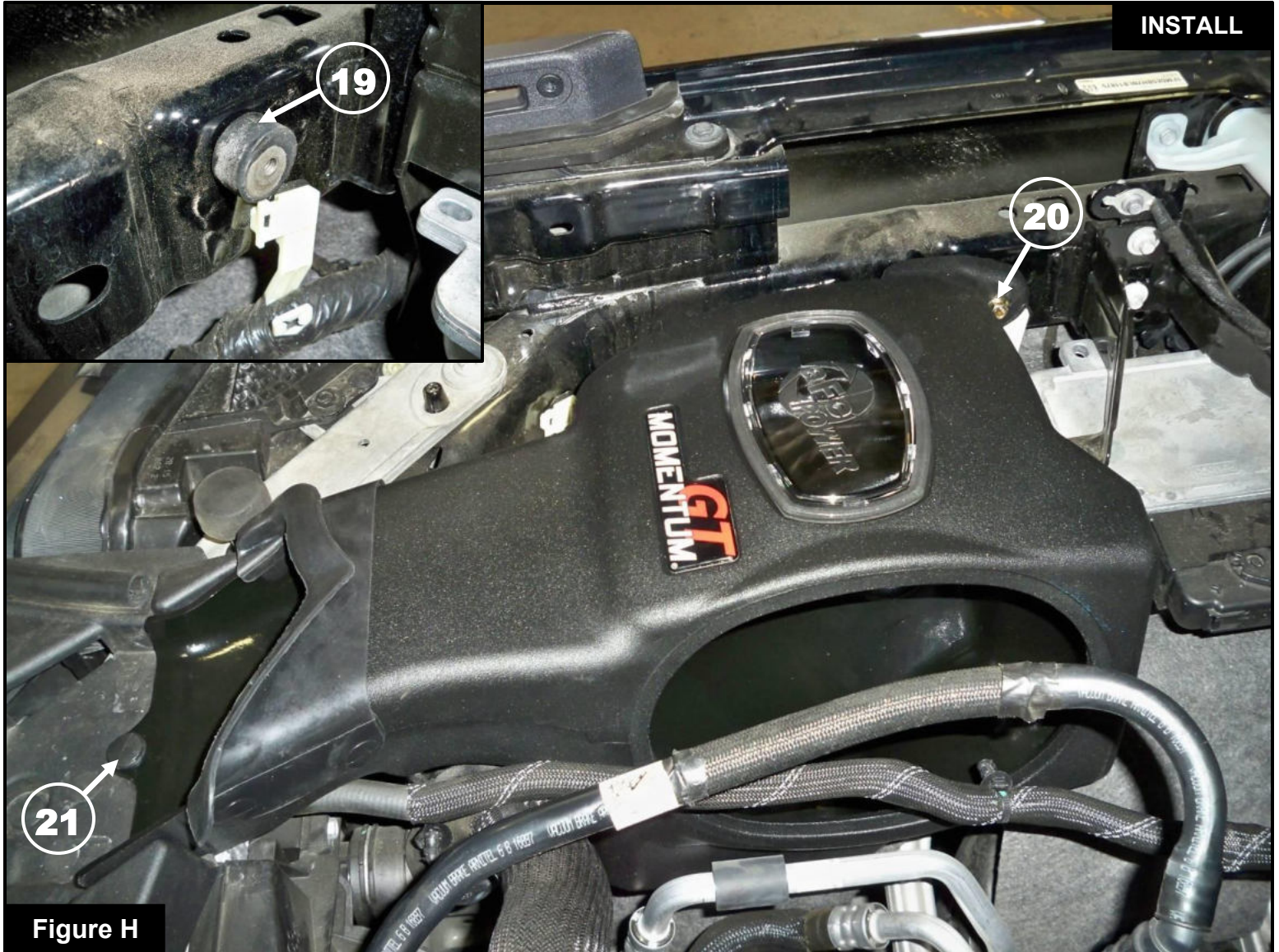

Refer to Figure H for Steps 16-19

Step 16: Screw in the supplied rubber isolator (19) as shown (where the screw was removed in Step 7).

Step 17: Install the aFe POWER housing into the vehicle. Make sure housing pins are aligned and all the way through the isolators.

Step 18: Using a 10mm socket and driver, install the supplied screw (20) to secure the aFe POWER housing and tighten.

Step 19: Install the retainer clip (21) removed in Step 1 to secure the aFe POWER housing.

**Figure 1****Refer to Figure 1 for Step 20**

Step 20: Slide the aFe POWER filter and clamp into the aFe POWER housing and push them in until it locks into place. Do not tighten the clamp at this time.

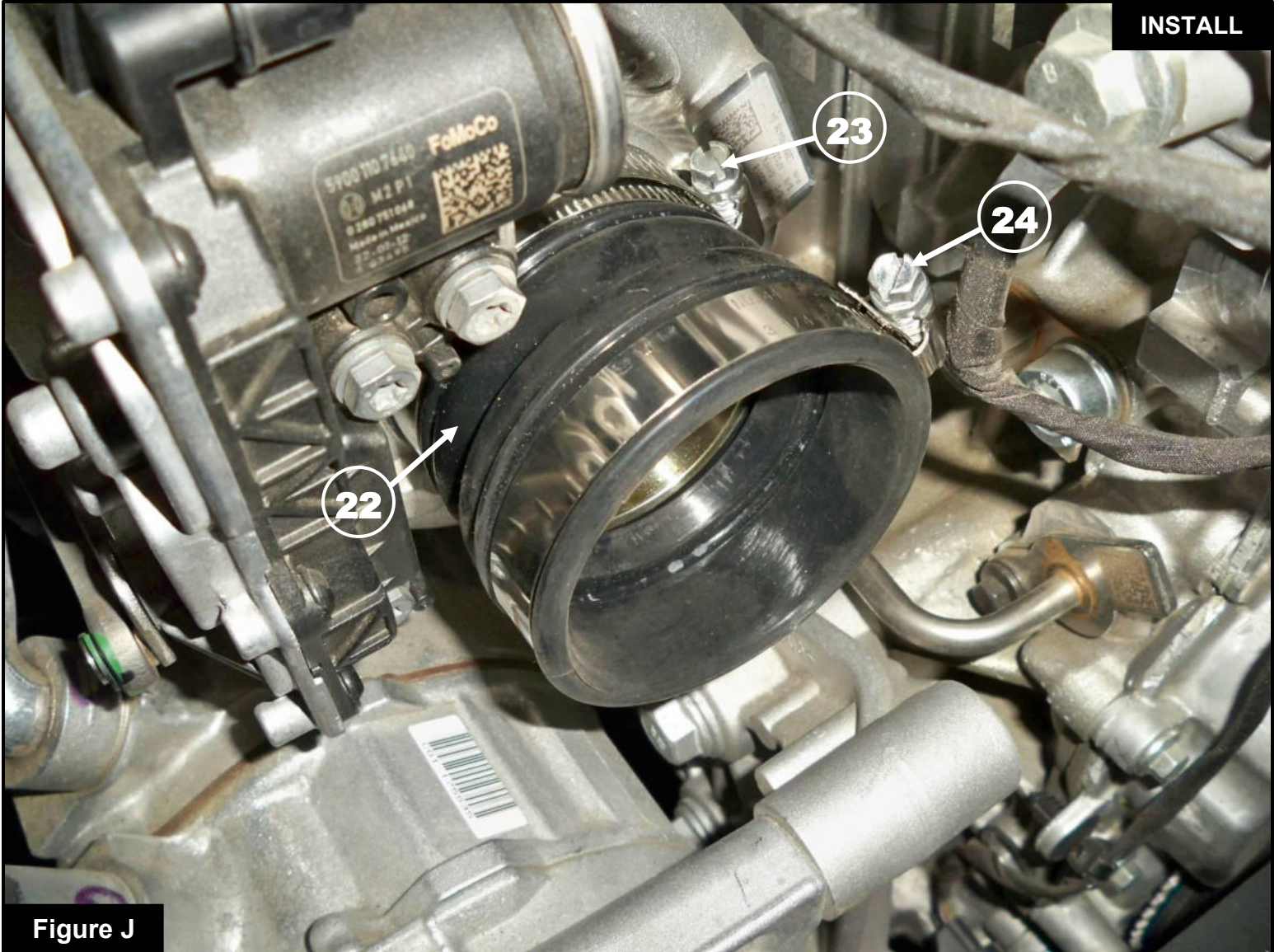
**Figure J****Refer to Figure J for Steps 21-22**

Step 21: Install the supplied coupling (22) onto the turbo with one of the supplied #44 clamps (23) and tighten the clamp using an 8mm nut driver.

Step 22: Place the other #44 clamp (24) onto the coupling and slightly snug so it will not fall off.

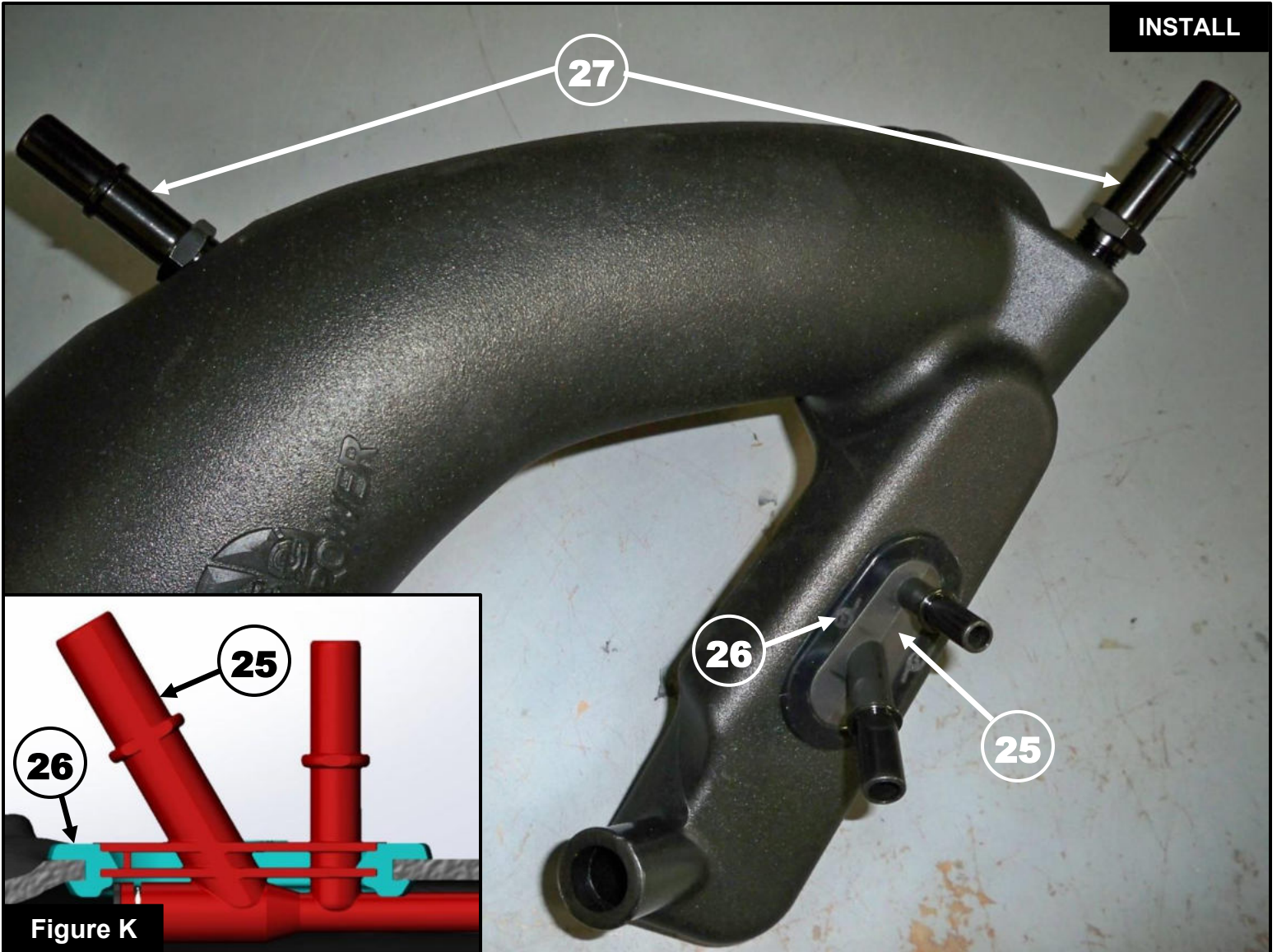

Refer to Figure K for Steps 23-25

Step 23: Install the supplied plastic fitting (25) into the fitting grommet (26). Make sure the inside thicker bead of the grommet is fully seated in between the two flat surfaces of the fitting (as shown in the drawing). The logo side of the grommet should seat flat to the fitting as shown.

Step 24: Install the fitting and grommet assembly into the aFe POWER intake tube. Make sure the grommet is fully seated to the intake tube so there are no leaks around the grommet area.

Step 25: Using a 20mm wrench or adjustable wrench, install the supplied aluminum vent fittings (27) into the aFe POWER intake tube. Do not overtighten, some threads will still be exposed.

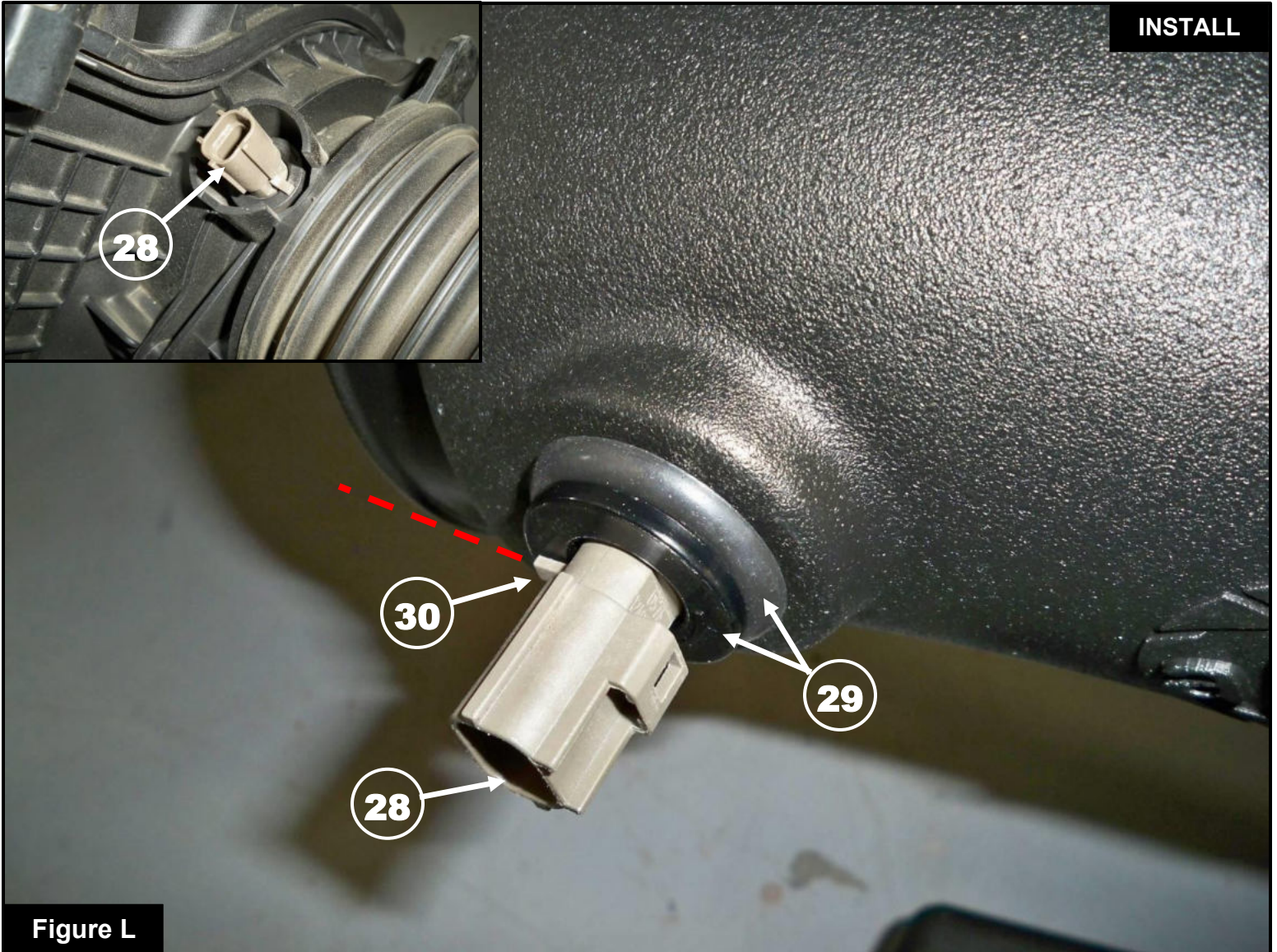
**Figure L****Refer to Figure L for Steps 26-28**

Step 26: Remove the IAT sensor (28) from the factory airbox by rotating ¼ turn counterclockwise and gently pulling out.

Step 27: Install the provided grommet and temp sensor fitting (29) into the aFe POWER intake tube.

Note: Lubricant can be used to facilitate the installation of the fitting into the grommet.

Step 28: Install the IAT sensor into the temp sensor fitting by rotating ¼ turn clockwise until it locks into place. *Being careful not to damage the AIT sensor*, rotate the temp sensor fitting to have mounting tab (30) pointing in the direction of the tube opening.

**Figure M****Refer to Figure M for Steps 29-31**

Step 29: Install the aFe POWER intake tube into the coupling first and then into the air filter. Align the tube correctly and tighten the clamps³¹ using an 8mm nut driver.

Step 30: Install the CAC inlet pipe. Align the pipe correctly and reinstall the screw removed in Step 14. Using a 10mm socket and driver, tighten down the screw.

Step 31: Using a 7mm nut driver, tighten the CAC inlet pipe clamps.

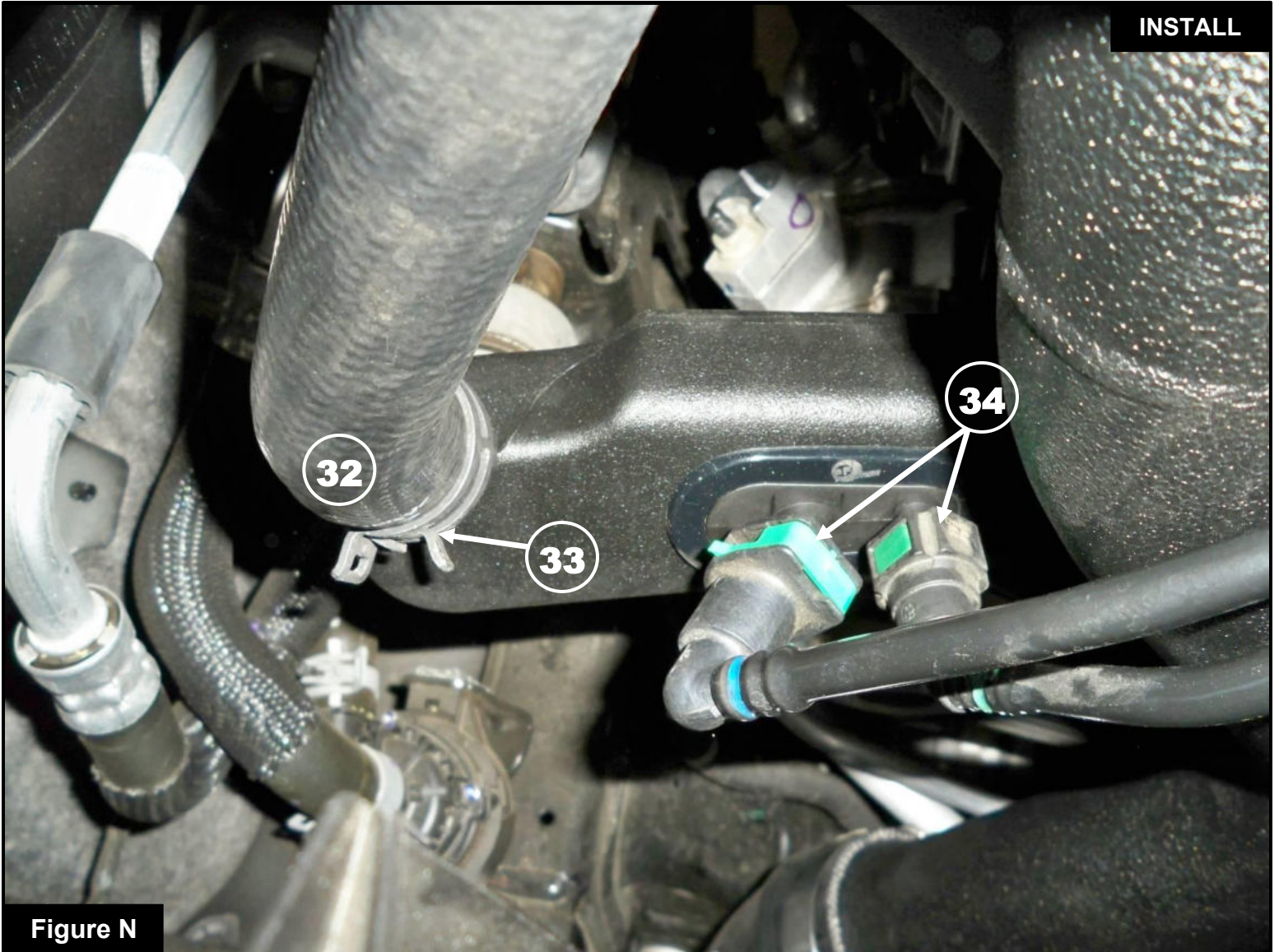
**Figure N****Refer to Figure N for Steps 32-33**

Step 32: Connect the bypass valve hose (32) and install the clamp (33) to secure.

Step 33: Connect the quick release connectors (34) for the fuel vapor hoses.

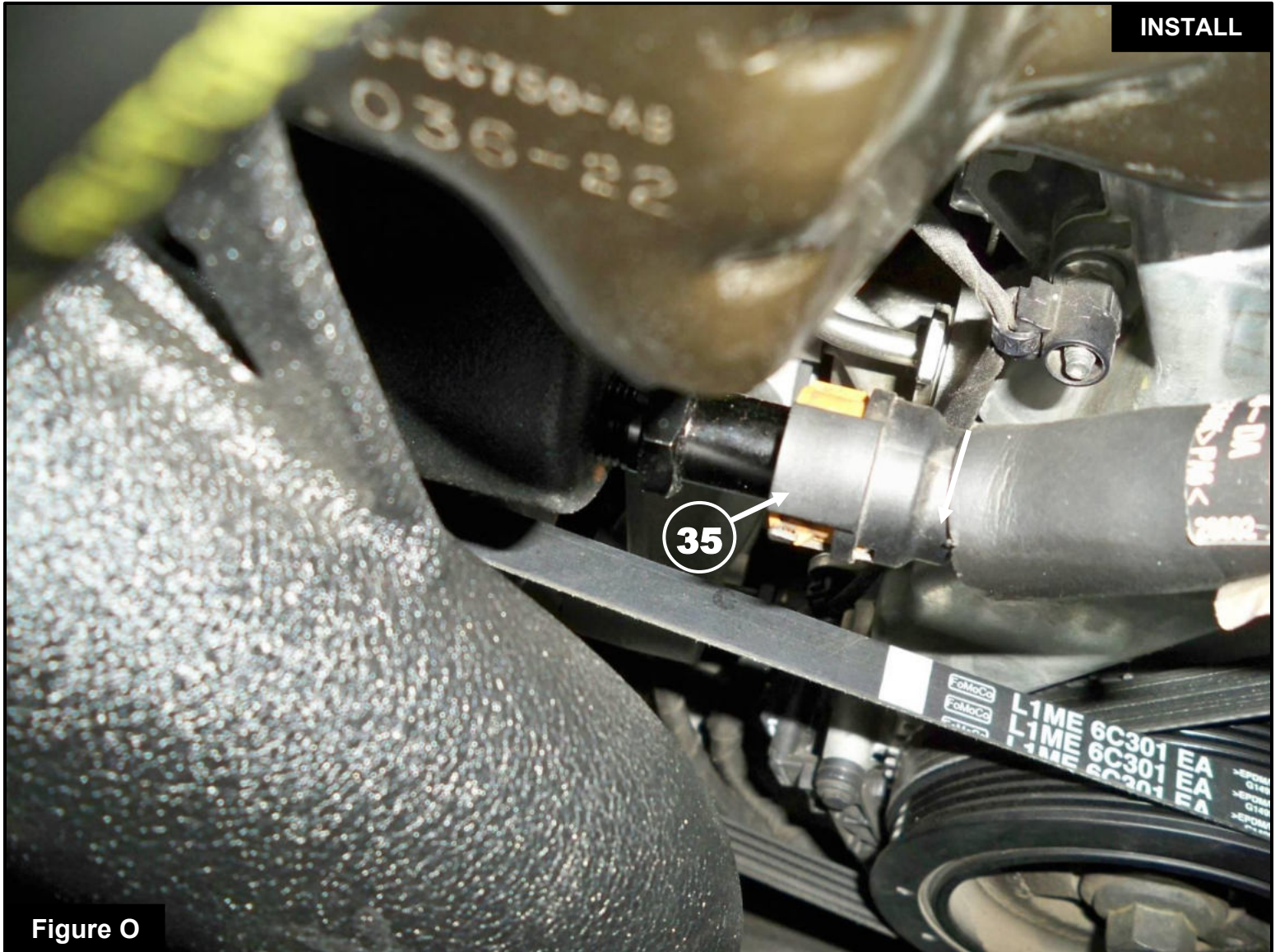
**Figure O****Refer to Figure O for Step 34**

Step 34: Connect the crankcase vent tube connector **35**. If the crankcase vent tube was previously cut, install a new crankcase vent tube.

PICTURE SHOWN WITH AFE CHARGE PIPES AND AFTERMARKET BOV

INSTALL



Figure P

Refer to Figure P for Steps 35-38

Step 35: Connect the bypass valve electrical connector (36) and retainer clips removed in Step 9. (See Step 9 for factory setup).

Step 36: Connect the quick release vent connector (37).

Step 37: Connect the IAT sensor electrical connector (38).

Step 38: Check all the components are tight and secure. Your installation is now complete. Thank you for choosing aFe POWER!

NOTE: Check all bolts, clamps, and connectors after 100-200 miles.



advanced FLOW engineering, inc.

252 Granite Street Corona, CA 92879

<https://afepower.com/contact>