

MOMENTUM *GT*

advanced FLOW engineering Cold Air Intake System

Instruction Manual P/N: 50-70104D / 50-70104R

Make: Volkswagen
Make: Audi

Model: GTI
Model: A3 (8Y)

Year: 2022
Year: 2022

Engine: L4-2.0L (t)
Engine: L4-2.0L (t)



- Please read the entire instruction manual before proceeding.
- Ensure all components listed are present.
- For technical support please call 951-493-7185.
- Ensure you have all necessary tools before proceeding.
- Do not attempt to work on your vehicle when the engine is hot.
- Retain factory parts for future use.

Label	Qty.	Description	Part Number
A1	1	Air Filter (Pro 5R)	24-91103
A2	1	Air Filter (Pro DRY S)	21-91103
B	1	Housing	05-5070087B2
C	1	Intake Tube	05-5070104B1
D	1	Coupling, Silicone Reducer	05-01528
E	1	Grommet, 1" ID	03-50139
F	1	Fitting, Smog Pump	05-01096
G	1	Clamp, #044	03-50019
H	1	Clamp, #048	03-50007
J	3	Grommet, Mounting	03-50647
K	1	Nipple, Brass 1/4"	03-50194
M	1	Inlet Trim	05-01657
N	1	Plug, Silicone	05-01482

Installation will require the following tools:

7mm & 8mm nut drivers, 1/2" deep socket and driver

Warranty Information available at <https://afepower.com/contact#warranty>

Emissions Disclaimer: This product is not currently CARB exempt and is not available for purchase in California or for use on any vehicle registered with the California Department of Motor Vehicles.

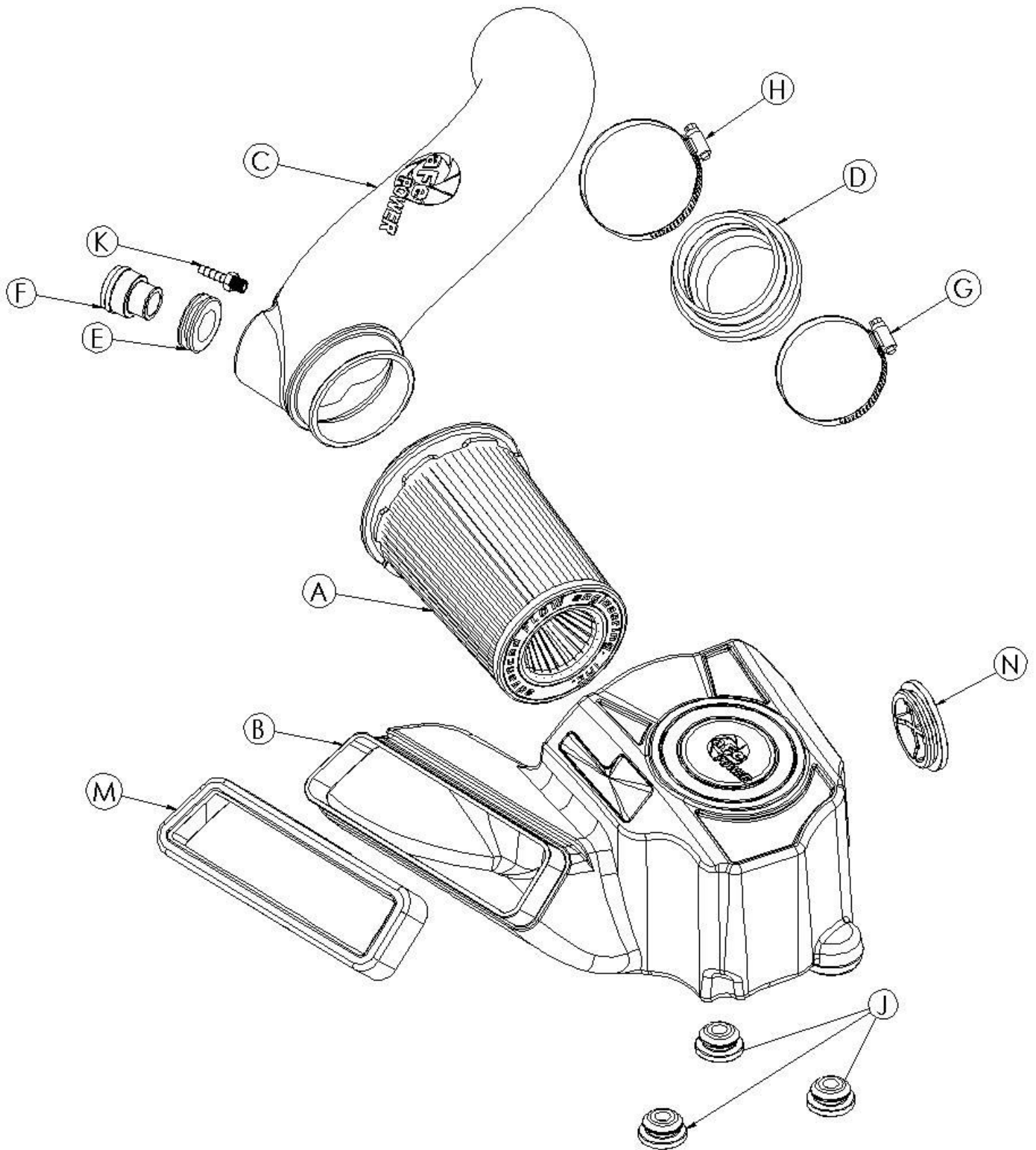



Figure A

Refer to Figure A for Steps 1-4

Step 1: Using a 7mm nut driver, loosen the clamp ② at the factory turbo inlet.

Step 2: Disconnect the CCV line ③ from the side of the factory filter housing.

Step 3: Disconnect the smog pump fitting ④ from the factory filter housing.

Step 4: Remove the factory filter housing and intake tube by pulling straight up off the mounting grommets.

**Figure B****Refer to Figure B for Steps 5-6**

Step 5: Install the supplied reducer coupling (5) and #044 clamp (6) with the smaller side on your turbo inlet and tighten using an 8mm nut driver.

Step 6: Place the #048 clamp (7) loosely around the open end of the coupler.

**Figure C****Refer to Figure C for Step 7**

Step 7: Install the 3 supplied silicone grommets ⑧ into the bottom of your aFe POWER filter housing.

**Figure D****Refer to Figure D for Step 8**

Step 8: Install the supplied silicone inlet trim ⑨ onto the inlet of your aFe POWER filter housing.

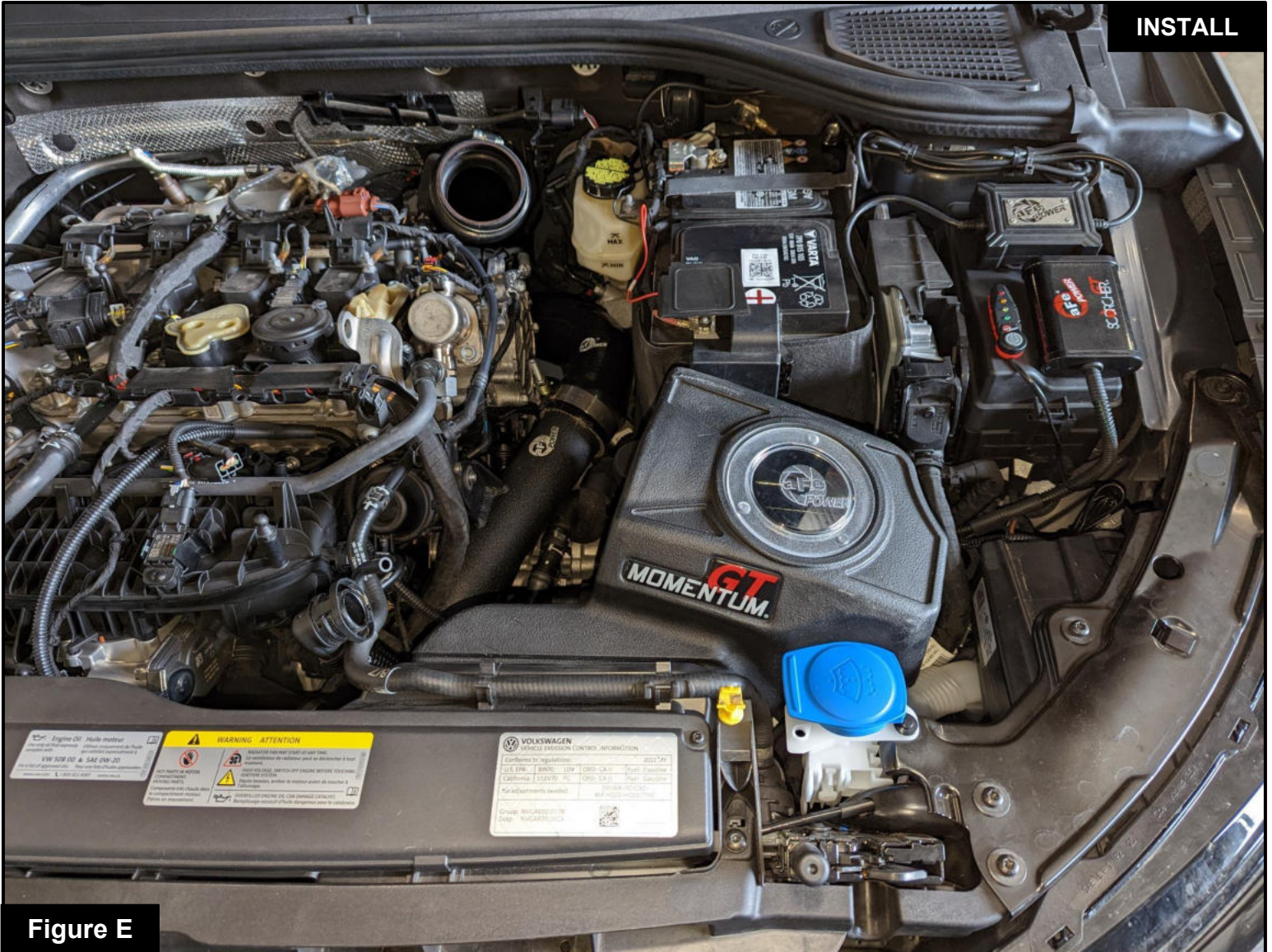
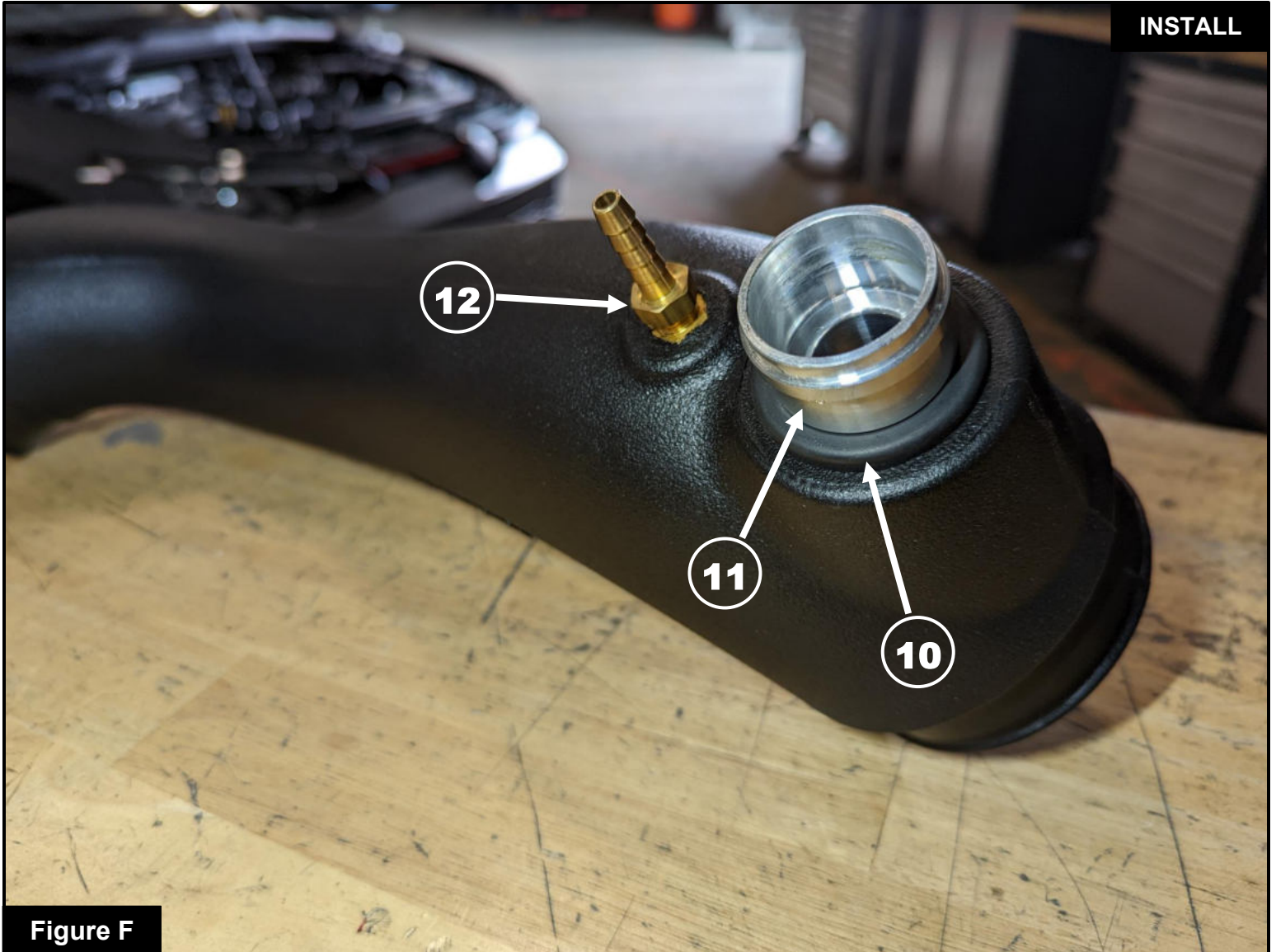

Figure E

Refer to Figure E for Step 9

Step 9: Install your aFe POWER filter housing into the vehicle by sliding the front inlet onto the OE scoop, then rotating the housing down onto the mounting points.

**Figure F**

Refer to Figure F for Steps 10-11

Step 10: Install the supplied 1" ID grommet (10) into the opening on your aFe POWER intake tube, then press the supplied aluminum fitting (11) into the grommet. Make sure the fitting is fully seated in the grommet for a good seal.

Step 11: Install the supplied 1/4" hose nipple (12) into the threaded fitting on the bottom of the intake tube. Use a 1/2" deep socket and driver to tighten the fitting. *This is an NPT syle fitting – some threads will still be exposed when the fitting it fully tightened. Do not overtighten the fitting or you risk stripping the insert out of the plastic*

**Figure G****Refer to Figure G for Step 12**

Step 12: Install your aFe POWER air filter into the filter housing by firmly pressing it into the opening until the small tabs are locked on the inside. Leave the clamp loose on the filter opening.



Refer to Figure H for Step 13

Step 13: Install your aFe POWER intake tube assembly first into the opening on the air filter, then rotate it downwards into the open end of the coupler at the turbo inlet. Use an 8mm nut driver to tighten all clamps.

**Figure I****Refer to Figure I for Steps 14-15**

Step 14: Reconnect the smog pump hose (13) to the fitting on the side of your aFe POWER intake tube.

Step 15: Connect the CCV hose (14) to the barbed fitting on the side of your aFe POWER intake tube.

**Figure J****Refer to Figure J for Step 16**

Step 16: (Optional) Use the provided plug (15) to close the additional air inlet if you want to completely seal the filter housing. Best performance is obtained without the plug.

Your Installation is now complete! Thank you for choosing aFe POWER!

NOTE: Check all clamps, and connectors are secure after 100-200 miles



THIS PAGE LEFT BLANK INTENTIONALLY



THIS PAGE LEFT BLANK INTENTIONALLY



advanced FLOW engineering, inc.

252 Granite Street Corona, CA 92879
TEL: 951.493.7100 • TECH: 951.493.7185
E-Mail: Tech@aFepower.com