

**GT**  
**MOMENTUM™**

advanced FLOW engineering

Instruction Manual P/N: 51-74101 & 54-74101

---

**Make:** Chevrolet/GMC **Model:** Trucks/SUVs **Year:** 99-07 **Engine:** V8-4.8L / 5.3L / 6.0L



- Please read the entire instruction manual before proceeding.
- Ensure all components listed are present.
- If you are missing any of the components, call customer support at 951-493-7185.
- Ensure you have all necessary tools before proceeding.
- Do not attempt to work on your vehicle when the engine is hot.
- Retain factory parts for future use.

Label	Qty.	Description	Part Number
A1	1	Pro DRY S Air Filter	21-91079 (Gray Media)
A2	1	Pro 5R Air Filter	24-91079 (Blue Media)
B	1	Tube	05-74003B1
C	1	Housing	05-74101B2
D	1	Hump Coupling	05-00565
E	1	Adaptor Coupling	05-01308
F	1	T-Bolt Clamp (8-5/16" to 8-5/8")	03-50267
G	2	Clamp #060	03-50002
H	1	Clamp #072	03-50010
J	1	Mounting Plate	05-01291
L	1	Urethane Plug	05-01202
K	1	Seal Trim - 26"	05-00072

Installation will require the following tools:

4mm Hex Key, 9/16 Wrench, 5/16 Nut Driver, 10mm Socket & Ratchet, T-15 Torx Driver.

Warranty Information available at: <https://afepower.com/contact#warranty>

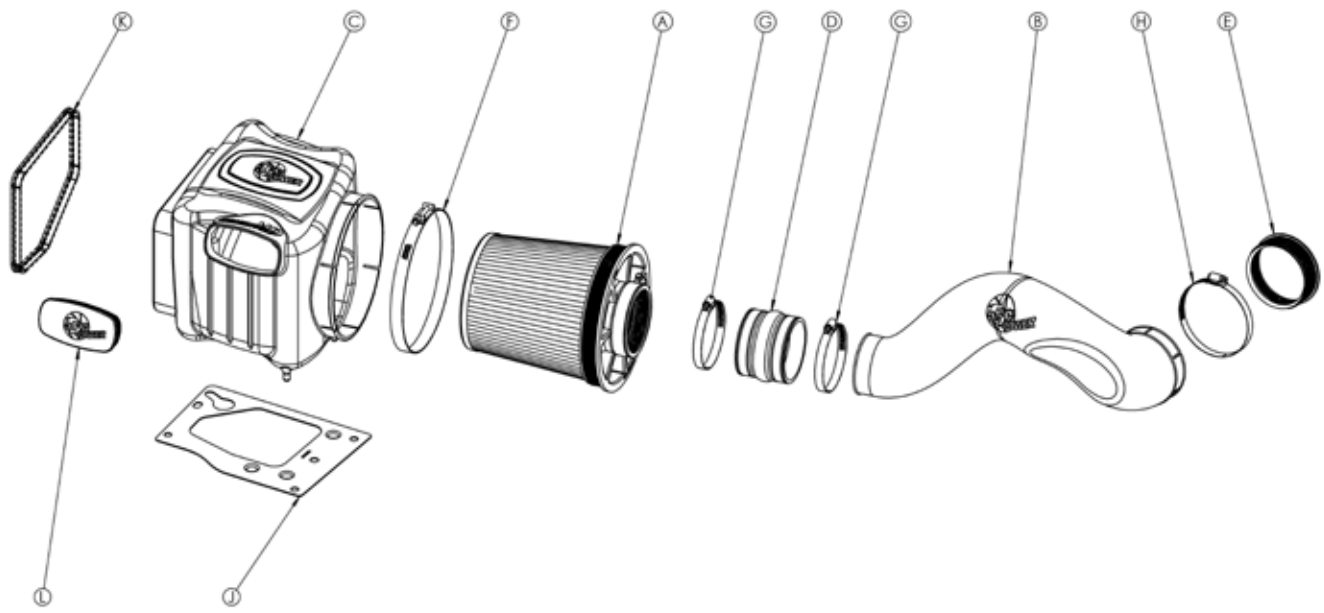



Refer to Figure A for steps 1-3

Step 1. Remove Engine Cover.

Step 2. Loosen the clamps attaching the tube to the intake housing and throttle body.

Step 3. Disconnect the wire harness from the MAF Sensor (1).



FigureB

Refer to Figure B for steps 4-5

Step 4. Remove the stock housing by lifting up and out.

Step 5. Detach the coolant hose support clip from the stock intake tube.



Figure C

Refer to Figure C for steps 6-8

Step 6. Remove the 4 bolts from stock housing bracket and save them for later use.

Step 7. Remove stock housing bracket.

Step 8. Remove the factory rubber grommets ① and save for later use.



Figure D

Refer to Figure D for steps 9-10

Step 9. Install aFe housing bracket and secure with the 4 stock bolts.

Step 10. Install the factory rubber grommets onto aFe mounting plate (2).



Figure E

Refer to Figure E for step 9

Step 9: Slide the air filter (E) into the air box (C). Install supplied T-bolt clamps (D & E).

(Do not tighten clamps at this time)

**IMPORTANT:** Prior to installation of T-bolt clamp, we recommend that you stretch the T-bolt clamps by installing it in its intended position and tightening.



Figure F

Refer to Figure F for steps 10 & 11

Step 10: Install the trim seal (B) on the edge of the Momentum air box.

Step 11: Remove the retaining plug (2) from the factory air box and install on the Momentum air box.



Refer to Figure G for steps 12-16

Step 12. Install the aFe airbox into the vehicle by firmly pushing it into the factory mounting grommets.

Step 13. Insert stock MAF cartridge into filter as shown (1).

Step 14. Tighten band clamp (2).

Step 15. Slip #60 band clamp over hump coupling and slip over MAF cartridge (3).

Step 16. Slide # 60 band clamp on hump coupling (4), do not tighten at this time.



Figure H

Refer to Figure H for step 17

Step 17. Install adaptor coupling over throttle body as shown.



Figure I

Refer to Figure I for steps 18-22

Step 18. Slide tube into hump coupling (1).

Step 19. Slip #72 band clamp over tube and slide tube over the adaptor coupling (2).

Step 20. Reconnect MAF sensor harness.

Step 21. Make sure all connections are secure and all clamps are tight.

Step 22. Re-install the engine cover. Your installation is now complete.

**NOTE: Retighten all connections after approximately 100-200 miles.  
Place enclosed CARB EO sticker on or near the device on a smooth, clean surface.  
EO identification label is required to pass the smog inspection.**



Page left blank intentionally



Page left blank intentionally

Page left blank intentionally



advanced FLOW engineering, inc.  
252 Granite Street Corona, CA 92879  
<https://afepower.com/contact>