

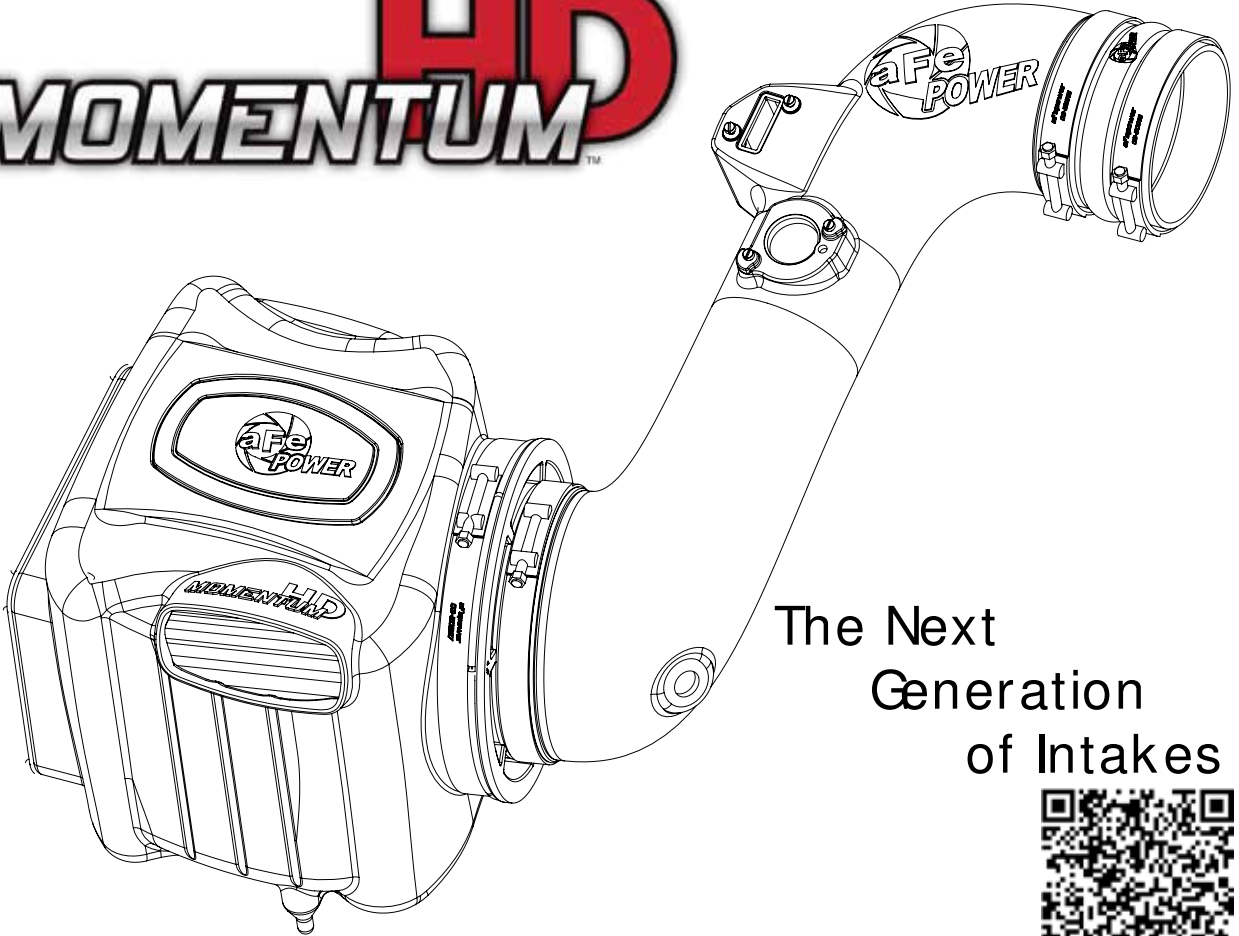

**MOMENTUM** **HD**



The Next  
Generation  
of Intakes



**advanced FLOW engineering**

Cold Air Intake System

**Instruction Manual** P/N: 50-74006-1/ 51-74006-1

Make: GM Model: Silverado HD/Sierra HD Year: 2011-2016 Engine: V8-6.6L (td) LML



- Please read the entire instruction manual before proceeding.
- Ensure all components listed are present.
- If you are missing any of the components, call customer support at 951-493-7185. or e-mail at [tech@afepower.com](mailto:tech@afepower.com).
- Ensure you have all necessary tools before proceeding.
- Do not attempt to work on your vehicle when the engine is hot.
- Disconnect the negative battery terminal before proceeding.
- Retain factory parts for future use.

Label	Qty.	Description	Part Number
A	1	Seal, Trim: 7/16" (26"L)	05-00072
B	1	Housing	05-82302B2
C	1	Plug, Urethane	05-01202
D	1	Clamp, T-bolt (8-5/16")	03-50267
E1	1	PRO 10R (Blue Media)	20-91059
E2	1	PRO DRY S (Grey Media)	21-91059
F	1	Tube	05-74006B1
G	1	Gasket	05-00631
H	1	Block Off Plate	05-01372
I	2	Screw, M4 x 12mm	03-50455
J	4	Screw, Torx: M4 x .7 x 8mm	03-50491
K	2	Clamp, T-Bolt (4-7/16")	03-50319
L	1	Coupling, Silicone Dbl. Hump	05-01430
M	1	Plug with Tab	03-50766

Installation will require the following tools:

8mm Nut driver, 10mm Nut driver and Torx (T-20) driver.

Warranty Information available at: <https://afepower.com/contact#warranty>

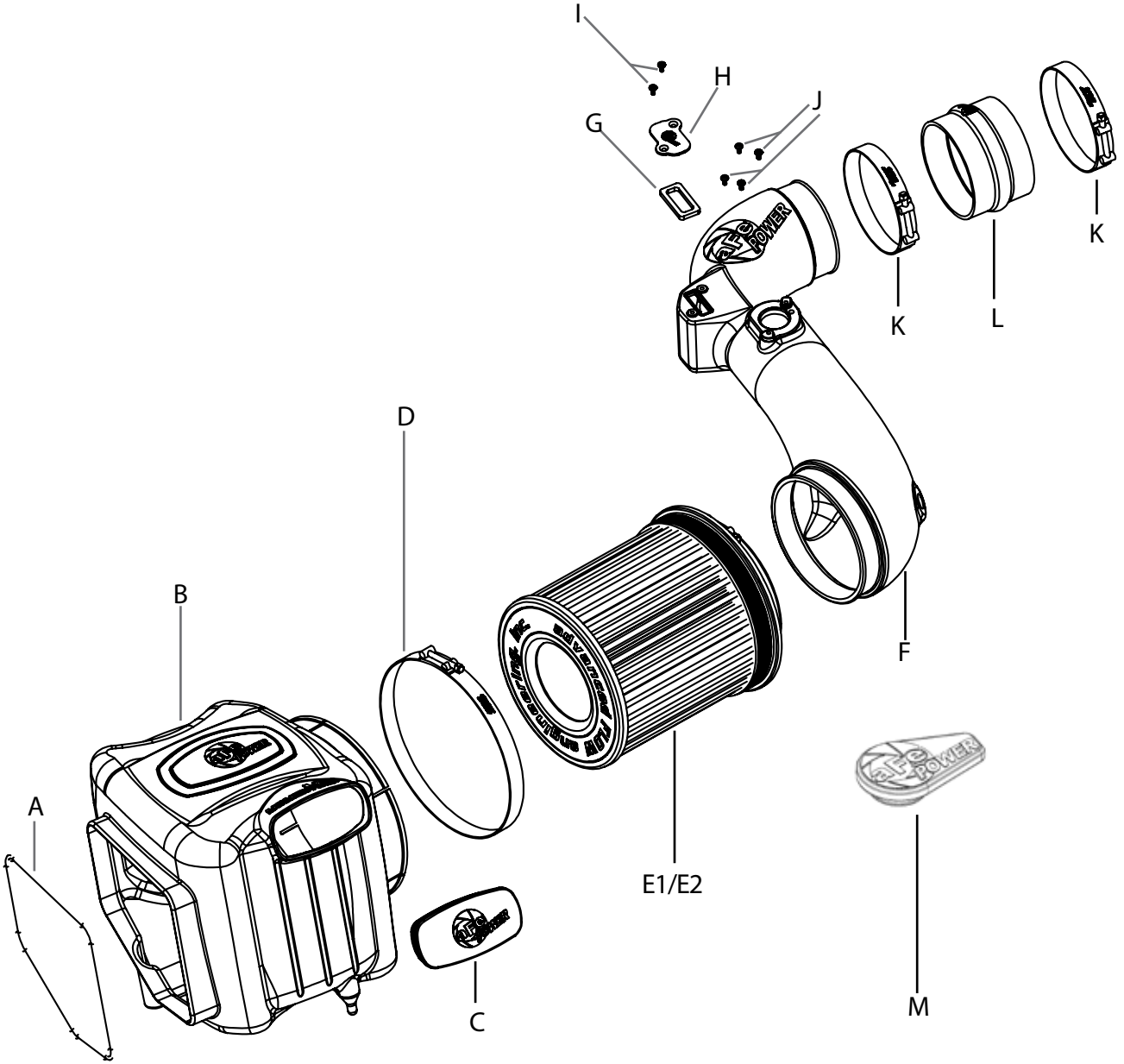



Refer to Figure A for steps 1-3

Step 1: Disconnect Mass Air Flow Sensor (1), Temperature Sensor (2) and Humidity Sensor (3).

Step 2: Loosen all tube clamps using a 8mm nut driver.

Step 3: Remove the factory intake tube and air box out of the vehicle. (Use an upward pull to release the air box from its mounting grommets).



Figure B

Refer to Figure B for step 4

Step 4: Slide the aFe filter into the air box. Install furnished T-bolt clamps. Do not tighten at this time.

**IMPORTANT:** Prior to installation of T-Bolt clamp, we recommend that you stretch the T-Bolt clamps by installing it in its intended position and tightening.



Figure C

Refer to Figure C for steps 5-7

Step 5: Install the trim seal on edge of the aFe air box (3).

Step 6: Remove the retaining plug (4) from the bottom of the factory air box.

Step 7: Install the plug on the aFe air box.



FigureD

Refer to Figure D for step 8

Step 8: Install the Momentum HD air box into the vehicle. Firmly push it into the factory mounting grommets.

**Figure E**

### Refer to Figure E for steps 9-13

Step 9: Remove Mass Air Flow Sensor and Humidity Sensor from the factory air box using a Torx (T-20) driver.

Step 10: Install Mass Air Flow Sensor and Humidity Sensor (use factory gasket for Humidity Sensor) into the Momentum HD intake tube using supplied M4 screws. If vehicle does not have the humidity sensor, use the supplied gasket, M4x 12mm flathead screws, and block off plate to seal opening.

Step 11: Remove the filter minder and grommet from factory air box.

Step 12: Install factory grommet into Momentum HD intake tube, then firmly press filter minder into it. If your vehicle is not equipped with a filter minder, just plug off the hole with the provided plug with tab.

Step 13: Install furnished silicone hump coupler and T-bolt clamps on the aFe tube. Do not tighten clamps at this time.



FigureF

Refer to Figure F for steps 14-15

Step 14: Install the Momentum HD tube into the vehicle. Slide the coupling in the turbo inlet tube first. Then rotate the tube down and slide it into the filter.

Step 15: Tighten all clamps.



FigureG

Refer to Figure G for steps 16-17

Step 16: Re-connect the Mass Air Flow Sensor and Humidity Sensor. Re-connect the temperature sensor by routing harness across the intake tube.

Step 17: Check all the components are tight and secure. Your installation is now complete. (Use furnished plug to close additional air inlet if you want to completely seal the air box.

Step 18: Re-connect negative battery terminal.

Step 19: (Optional) To seal up auxiliary opening of air box positioned in front of grill, use supplied plug.

NOTE: Check all bolts, clamps, and connectors after 200 miles. Place enclosed CARB EO sticker on or near the device on a smooth/clean surface. EO identification label is required to pass the smog test inspection.

Page left blank intentionally



advanced FLOW engineering, inc.  
252 Granite Street Corona, CA 92879  
<https://afepower.com/contact>