



advanced FLOW engineering Momentum Air Intake

**Instruction Manual** P/N: 50-73002 / 51-73002 / 75-73002

Make: **Ford** Model: **F-250/350/450/550** Year: **1999.5-2003** Engine: **V8-7.3L (td)**

Make: **Ford** Model: **Excursion** Year: **2000-2003** Engine: **V8-7.3L (td)**



- Please read the entire instruction manual before proceeding.
- Ensure all components listed are present.
- If you are missing any of the components, call customer support at 951-493-7100.
- Ensure you have all necessary tools before proceeding.
- Do not attempt to work on your vehicle when the engine is hot.
- Disconnect the negative battery terminal before proceeding.
- Retain factory parts for future use.

| Label | Qty. | Description                              | Part Number |
|-------|------|--|-------------|
| A1    | 1    | Air Filter (Pro 10R)                     | R20B91061   |
| A2    | 1    | Air Filter (Pro DRY S)                   | R21B91061   |
| A3    | 1    | Air Filter (Pro-GUARD 7)                 | R72B91061   |
| B     | 1    | Tube, Rotomold                           | 05-73002B1  |
| C     | 1    | Housing, Rotomold                        | 05-73002B2  |
| D     | 1    | Bracket, Battery Mount                   | 05-01062    |
| E     | 2    | Clamp, T-Bolt (4-1/8" - 4-1/2") (SS)     | 03-50262    |
| F     | 1    | Clamp, T-bolt (3-5/16" - 3-5/8") (SS)    | 03-50292    |
| G     | 1    | Clamp, T-bolt (8-5/16" - 8-5/8") (SS)    | 03-50267    |
| H     | 1    | Coupling, Silicone: 3" Turbo Adptr       | 05-01318    |
| I     | 1    | Coupling Silicone Hump: 4" ID x 2-1/2" L | 05-01332    |
| J     | 1    | Grommet, Rubber: MS35489-100             | 03-50076    |
| K     | 1    | Screw, Btn Hd Socket: M6x1x12            | 03-50102    |
| L     | 4    | Washer, Flat M8: 16mm OD S/S             | 03-50159    |
| M     | 2    | Screw, Socket Hd Cap: M8x1.25x110        | 03-50468    |
| N     | 2    | Screw, Socket Hd Cap: M8x1.25x30         | 03-50379    |
| Q     | 1    | Snorkel, Urethane:                       | 05-01366    |
| P     | 1    | Clamp, T-Bolt (4-5/16" - 4-5/8")         | 03-50499    |

Tools needed: 8mm Nut driver, 10mm Nut Driver, 1/4" Ratchet, 8mm, 10mm, and 13mm Sockets, Flathead Screw Driver.

Warranty Information available at: <https://afepower.com/contact#warranty>

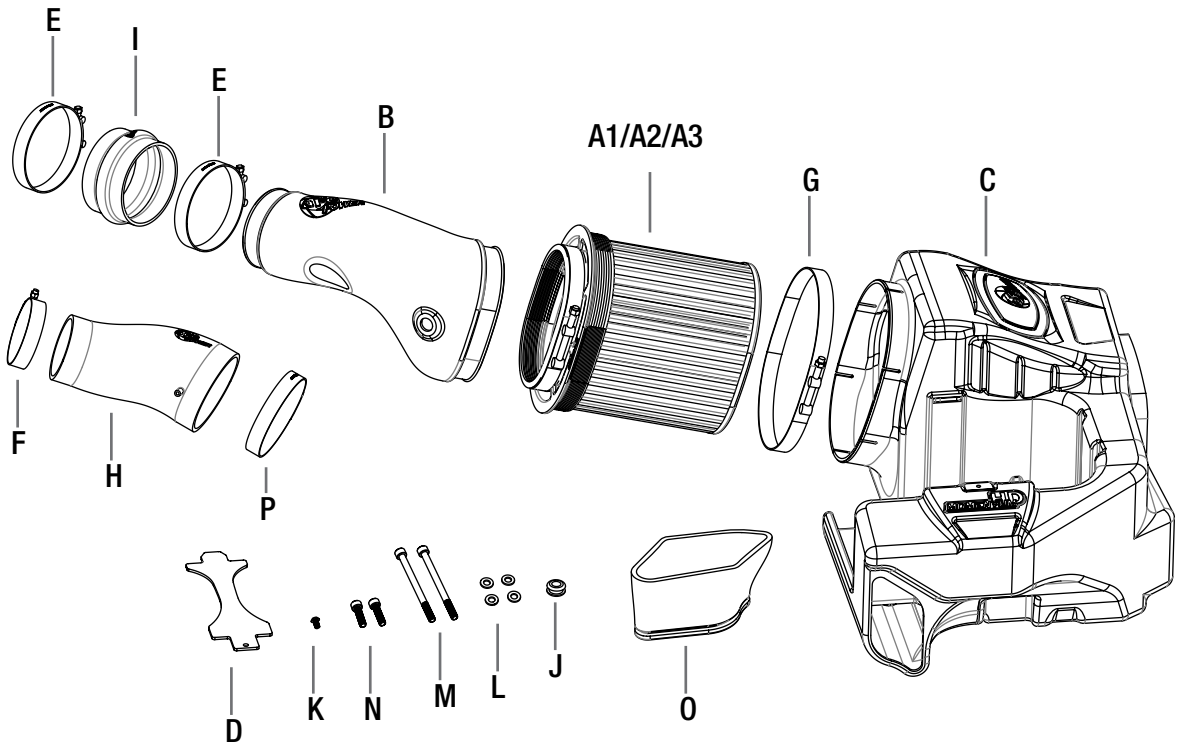



**Refer to Figure A for Steps 1-2**

Step 1: Disconnect both battery terminals from the driver side battery (1) and the negative terminal from the passenger side battery (2).

Step 2: Unsnap the battery cover and remove it from the vehicle (if equipped).



Figure B

**Refer to Figure B for Step 3**

Step 3: Use an 8mm to loosen the battery bracket ③ on the driver side battery, and then remove the battery from the vehicle.



Figure C

**Refer to Figure C for Step 4**

Step 4: Use an 8mm nut driver to loosen the two clamps (4) on the intake tube, and then remove the stock intake tube.

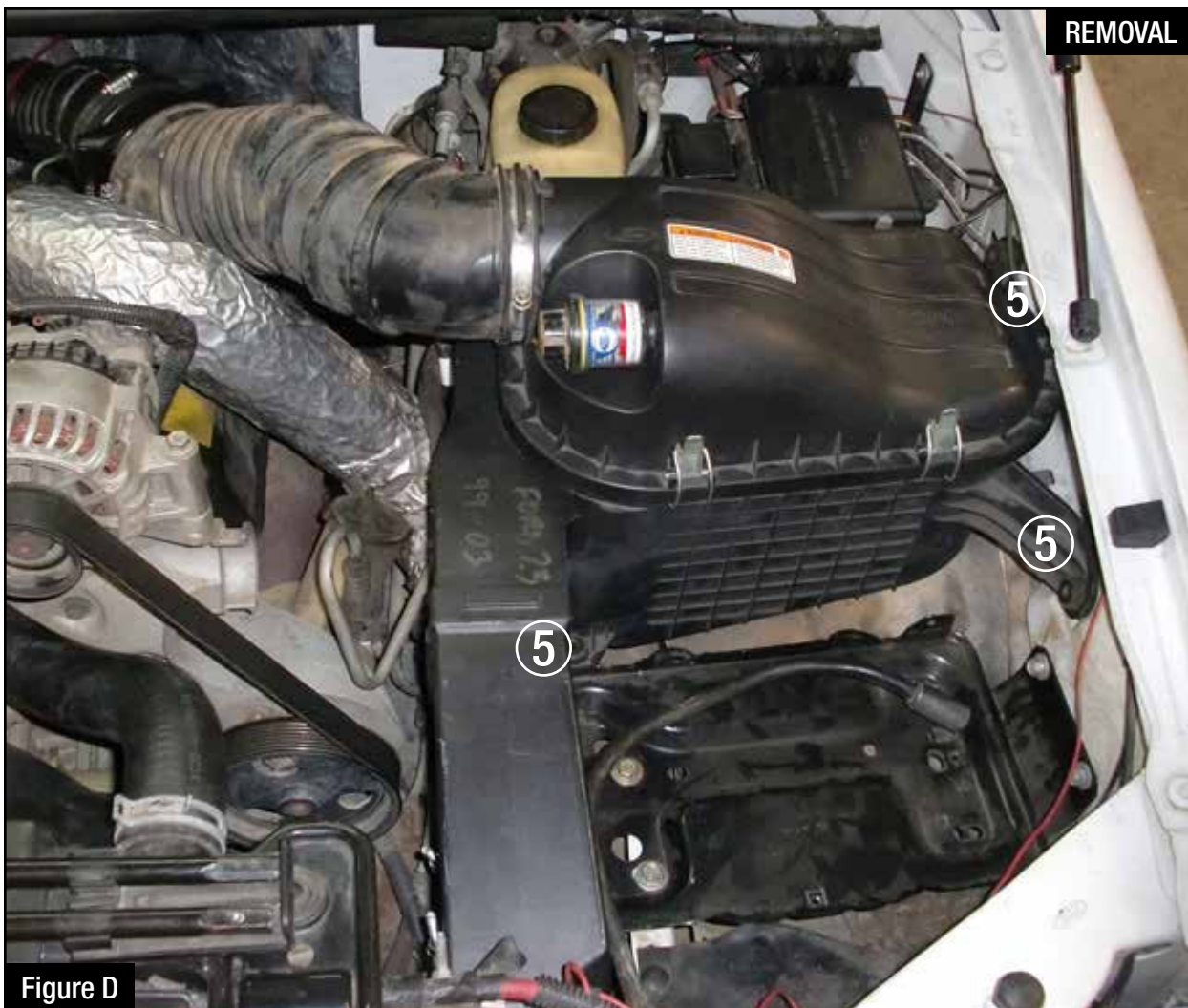

### **Refer to Figure D for Steps 5-6**

Step 5: Use a 10mm socket and driver to remove the 3 screws (5) on the intake housing.

Pull up slightly on the housing and disconnect the temperature sensor on the back of the housing before removing the entire housing from the vehicle.

Step 6: Use a 13mm to remove the factory battery tray.



**Refer to Figure E for Steps 7-8**

Step 7: Using an 8mm socket, remove the two screws (6) in the back of the Crank Case Vent (CCV) adaptor. Unplug the green plastic tube (7) that's plugged into the side of the tube.

Step 8: Loosen the two clamps (8) on the rubber intake tube and then remove the tube from the vehicle.



Figure F

**Refer to Figure F for Step 9**

Step 9: Reroute the battery cable under the brake lines so that it sits in front of the ABS manifold as shown.



Figure G

**Refer to Figure G for Steps 10-11**

Step 10: Remove the Filter minder and grommet from the factory air box.

Step 11: Remove the temp sensor from the factory air box by twisting a CCW quarter turn and then pulling gently. (Not Shown)

**Figure H****Refer to Figure H for Step 12**

Step 12: Install the supplied grommet (9) into the back side of the new aFe air box, and install the factory temp sensor into the grommet.



Figure 1

**Refer to Figure 1 for Step 13**

Step 13: Install the supplied urethane air inlet onto the front of the aFe air box.

Note: this is a directional fit, so be sure to match the profile of the inlet to the cut in the aFe air box.



**Figure J**

**Refer to Figure J for Steps 14-16**

Step 14: Install the new silicone torque booster intake tube between the turbo and the CCV adaptor using the supplied stainless steel clamps.

Step 15: Reinstall the screws into the CCV adaptor to bolt it up to the factory location. Leave the clamps loose at this time.

Step 16: Plug in the green tube (10) into the side of the new silicone intake tube.

**Figure K****Refer to Figure K for Steps 17-19**

Step 17: Install the new aFe housing into the truck at such an angle so that the urethane inlet goes into the opening beside the intercooler.

Step 18: As you install the housing, feed the negative battery lead through the hole (11) on the bottom of the aFe air box.

Step 19: Plug in the temp sensor on the back side of the housing (12).



Figure L

**Refer to Figure L for Step 20**

Step 20: Once the housing is in place, then secure it using the provided bolts and flat washers.

It is easiest to loosely install the bolts in the fender first (13) and then install the bolts and washers thru the bottom of the housing (14).



Figure M

**Refer to Figure M for Step 21**

Step 21: Install the new aFe air filter into the housing, and place the furnished large clamp over the flange on the housing. Leave both clamps loose at this time.



**Figure N**

**Refer to Figure N for Step 22**

Step 22: Install the factory grommet and the filter minder into the small hole on intake tube.



**Refer to Figure 0 for Steps 23-24**

Step 23: Place the silicone coupler and the remaining two stainless steel clamps onto the end of the new aFe intake tube (15).

Step 24: With both clamps loose, slide the coupling over the CCV adaptor first and then slide it down into the filter.



Figure P

**Refer to Figure P for Step 25**

Step 25: With the negative battery cable pulled out of the way, reinstall the battery into the aFe housing.

Note: The aFe air box is design to fit a factory specified Group 65 battery.

**Figure Q****Refer to Figure Q for Steps 26-27**

Step 26: Install the supplied stainless steel bracket into the slot on the housing and line up the hole on the bracket with the insert on the housing.

Step 27: Use the furnished M6 button head screw (16) to secure the battery in place.

Note: make sure the battery is secure and does not move. If for some reason there is a gap between the battery and the bracket, then rubber tape may be used on the bottom of the bracket to ensure constant contact on the battery.



**Figure R**

**Refer to Figure R for Steps 28-29**

Step 28: Reconnect the positive and negative power cables to the battery terminals and tighten.

Any excess wire from the negative cable can be pushed down into the front of the air box for a professional looking install.

Step 29: Reconnect the battery on the passenger side and tighten the lead.

**Figure S****Refer to Figure S for Step 30**

Step 30: Tighten all clamps at this time and make sure that all connectors are plugged in.

Your install is now complete! Thank you for choosing aFe Power!

*NOTE: Retighten all connections after approximately 100-200 miles. Place enclosed CARB EO sticker on or near the device on a smooth/clean surface. EO identification label is required to pass the smog test inspection.*

Page left blank intentionally.



advanced FLOW engineering, inc.  
252 Granite Street Corona, CA 92879  
TEL: 951.493.7155 • TECH: 951.493.7100  
E-Mail: [Tech@aFepower.com](mailto:Tech@aFepower.com)